

Analysis of Train-Overturn Derailments Caused by Excessive Curving Speed

A. Matsumoto;
Japan Transport Safety Board (JT S B)

Y. Michitsuji, Y. Tobita; Ibaraki University

1. Introduction (1/2)

Train-overturn derailment accidents are very terrible, but, not a small number of such a kind of accidents occurred in recent years.

We had a very serious accident on Fukuchiyama line near Osaka 10 years ago, and the governmental accidents investigation commission ARAIC, the former organization of JTSSB, carried out the investigation and published the investigation report, including countermeasures.

But recurrent accidents happened in some countries after that. It is very regrettable for us not to share the information, and not to prevent recurrences of the same kind of accidents.

“Train overturn derailments” are different phenomena from “flange climb derailments” and they are rather simple phenomena, but it is very important to grasp the basic phenomena and to recognize the safety limit against them.

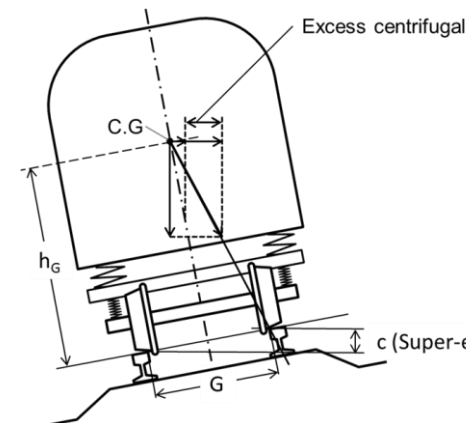

1. Introduction (2/2)

In this paper the authors analyze the outline of the previous 5 serious train overturn accidents within 10 years, and consider the common and particular features of these accidents.

Then by using a Japanese traditional simplified formula “Kunieda’s formula” and a multi-body dynamics simulation program SIMPACK, the basic analyses on train overturning phenomena are carried out.

Finally the authors attempt to organize the basic concept of prevention against such a kind of accidents to get global collaboration in deriving teachings from accidents.

2. Features of previous train-overturn accidents

- 1) **Fukuchiyama line** accident of JR West near Osaka in 2005; Japan
- 2) **Glacier express** accident in 2010; Switzerland
- 3) **Renfe high speed train** accident in 2013; Spain
- 4) **New York Metro North Railroad** accident in 2013; USA
- 5) **Amtrak** high speed train accident near Philadelphia in 2015; USA
- 6) **SNCF TGV** new line in November 14 of 2015; France



2. Features of previous train-overturn accidents

1) Fukuchiyama line accident of JR West near Osaka in 2005; Japan

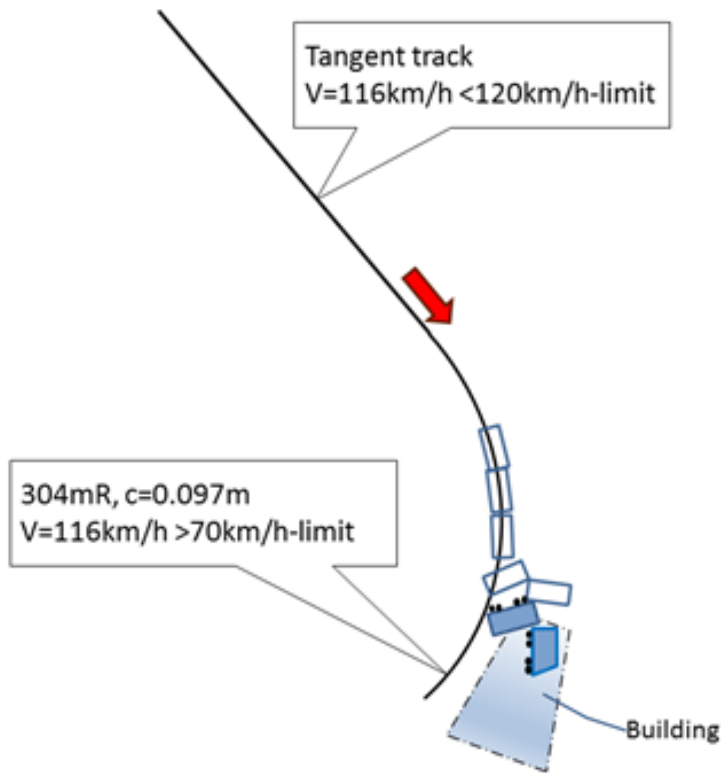

- *Commuter train set of 7 EMUs for narrow gauge track
- *Leading 2 vehicles overturned, next 2 vehicles heavily deviated from track
- *Leading 2 vehicles terribly crashed to a building at track side
- *Leading 4 vehicles heavily buckled

2. Features of previous train-overturn accidents

2) Glacier express accident in 2010; Switzerland

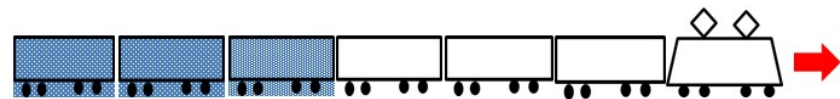
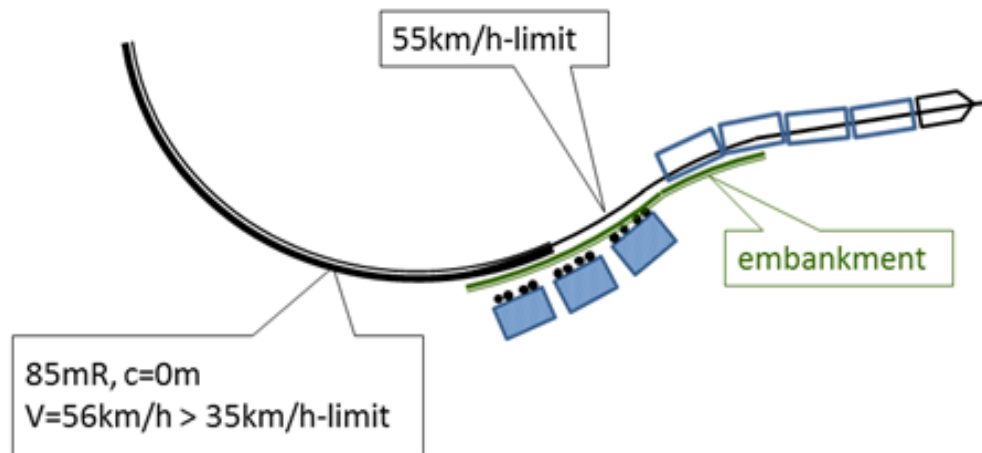

- *"Glacier Express"; sightseeing train of 1 EL +6 PCs for meter gauge track
- *3 trailing PCs including "panorama car" overturned and fell down from embankment

2. Features of previous train-overturn accidents

3) Renfe high speed train accident in 2013; Spain

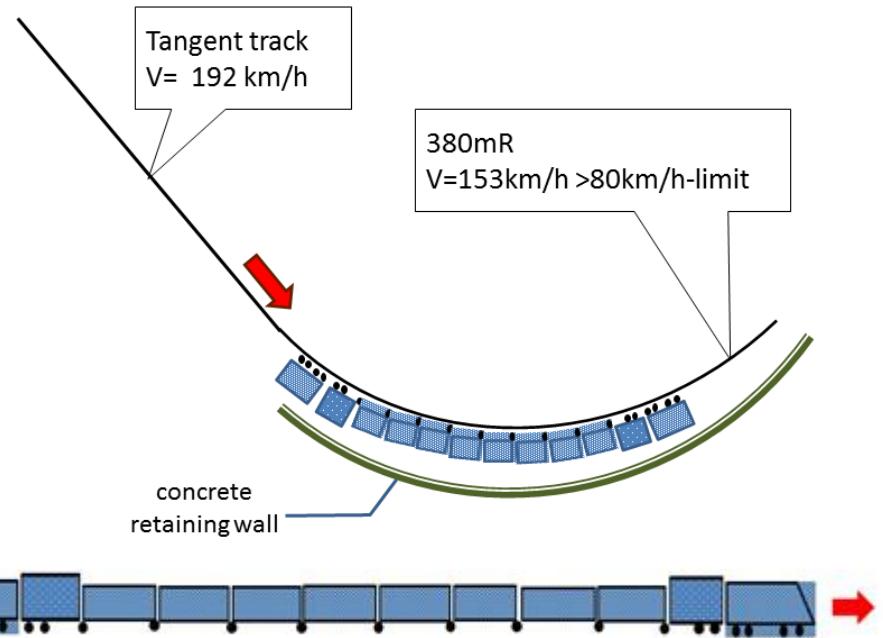

- *RENFE high speed gauge-changing train for hybrid powering; type S730
- *2 x (EL + power unit) + 8 mono-axle & articulated (Talgo-type) PCs
- *All vehicles overturned and fell down to concrete retaining wall
- *Especially 2 power unit vehicle named "technical end coaches" leaned early, which were recognized in the monitor video from wayside

2. Features of previous train-overturn accidents

4) New York Metro North Railroad accident in 2013; USA

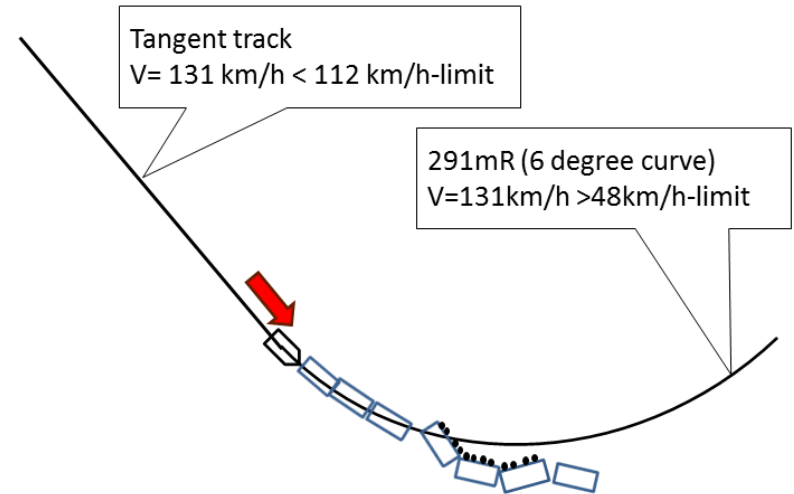

*Commuter train of 7 PC + 1 EL in push-pull operation

*Leading 4 vehicles overturned or heavily deviated from track

2. Features of previous train-overturn accidents

5) Amtrak high speed train accident near Philadelphia in 2015; USA

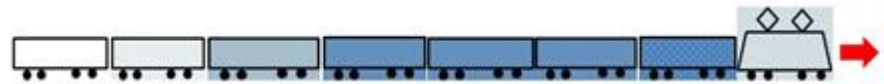
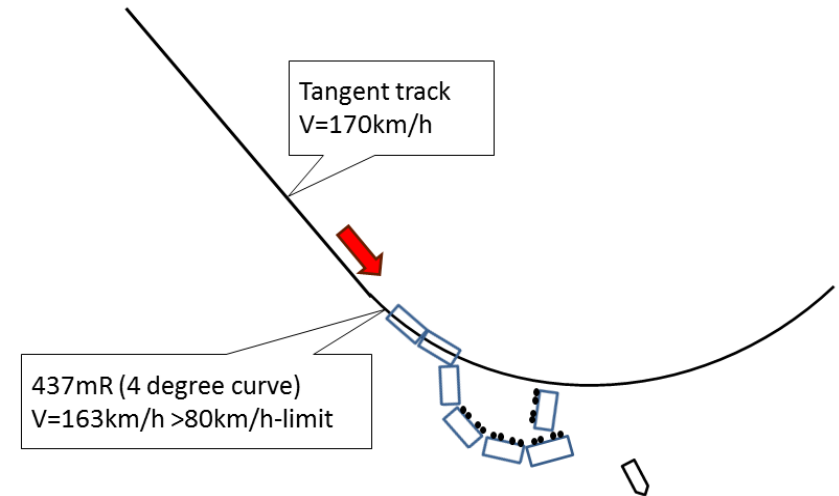

- *AMTRAK high speed train of 1 EL and 7 PCs
- *Leading 5 PCs overturned or heavily deviated from track
- *Leading EL deviated heavily from track, but not overturned

2. Features of previous train-overturn accidents

Overview of 5 serious accidents

Accident Name	Kind of Train	Gauge (mm)	Curving radius (m)	Running speed (km/h)	Speed limit (km/h)	Estimated limit speed against overturn (km/h)
Fukuchiyama L. (Japan)	Commuter (EMUs)	1067	304	116	70	(106-108)
Glacier express (Swiss)	Sight-seeing (EL+PCs)	1000	85	56	35	(52 - 55)
Spanish high speed train (Spain)	High speed (composed train set)	1668	380	153	80	(130-145)*
NY Metro North Rail (USA)	Commuter (push-pull)	1435	291	131	48	(115-125)*
Amtrak Philadelphia (USA)	High speed (EL+PCs)	1435	437	163	80	(130-140)*

2. Features of previous train-overturn accidents



1) Fukuchiyama line
7 EMUs

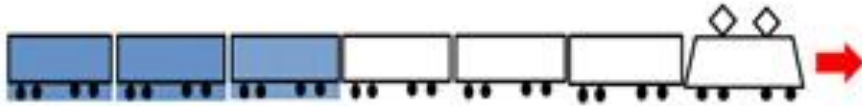

2) Swiss Glacier exp
EL+6PCs



3) Spanish high speed
2*(EL+PU) +8PCs



4) NY Metro North R
7 PCs + EL (push-pull)



5) Amtrak high speed
EL + 7 PCs

3. Analysis of train overturning mechanism

3.1 Basic mechanism of train overturning

The vehicle is overturned when the curving speed exceeds the speed limit, where the resultant force vector composed by the centrifugal force, the gravity and the inertial force of lateral vibration goes toward outside of the track from the gravity center of the vehicle.

Therefore “Overturn” is different phenomena from “flange climb”, and the lateral contact forces between wheel and rail rarely influence to the overturn movement of the vehicle.

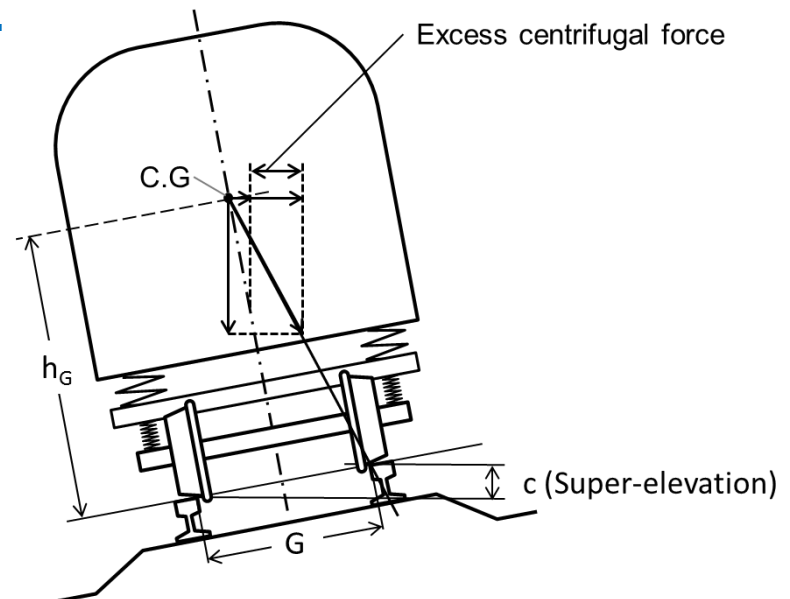

3.2 Kunieda's formula

The “Kunieda's formula” is a simplified formula, to calculate the risk against “train overturning”, considering the centrifugal force of curving, the vehicle vibration (especially lateral) and the side wind effect, proposed by Dr. M. Kunieda.

It is a simplified equation based on the static mechanism, but agrees well with real phenomena.

It has been certificated in many cases and used for the guideline of safety in Japan. In this paper the validity of this equation will be verified by comparing with SIMPACK multi-body dynamics simulation.

Kunieda's formula

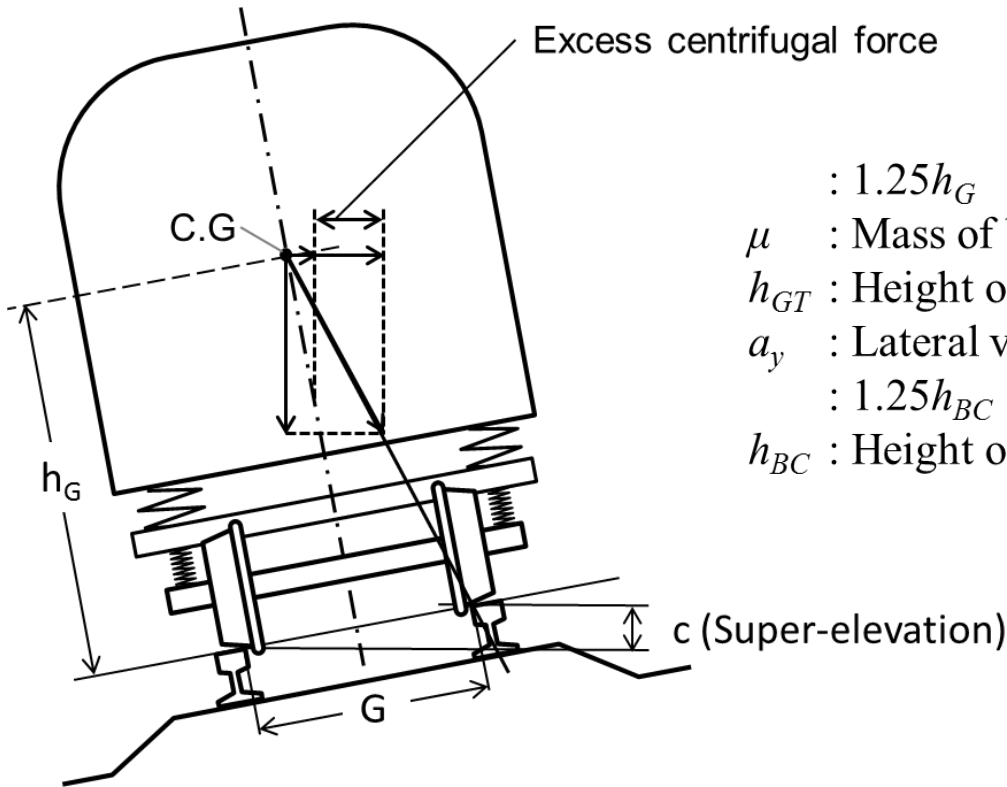

- $1.25h_G$
- μ : Mass of bogie/Half mass of car body
- h_{GT} : Height of center of gravity of the bogie
- a_y : Lateral vibrational acceleration of the car body
- $1.25h_{BC}$
- h_{BC} : Height of center of wind force from the rail top

$$D = \frac{2h_G^*}{G} \left(\frac{v^2}{R \cdot g} - \frac{c}{G} \right) + \frac{2h_G^*}{G} \left(1 - \frac{\mu}{1 + \mu} \cdot \frac{h_{GT}}{h_G^*} \right) \cdot \frac{\alpha_y}{g} + \frac{h_{BC}^* \rho \cdot u^2 \cdot S \cdot C_D}{m \cdot g \cdot G}$$

Unbalanced centrifugal acceleration

Lateral vibration acceleration

Side wind force

4. Multi-body dynamics simulation of train overturns

Vehicle model by SIMPACK

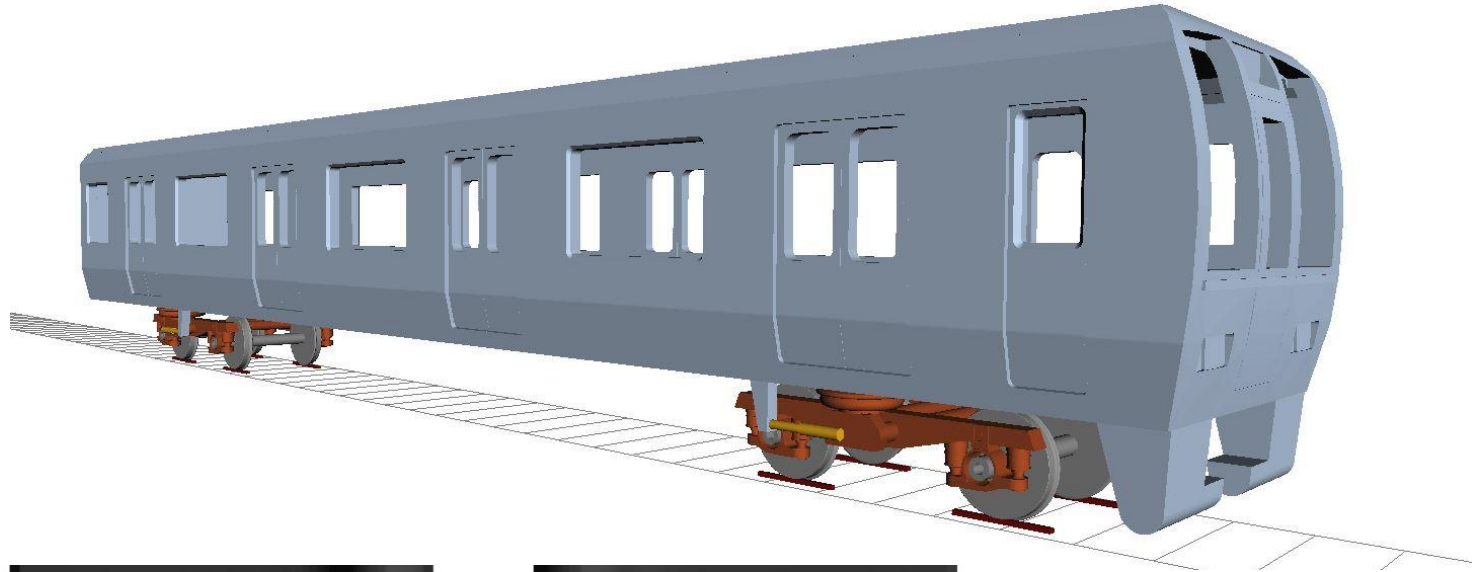

Wheel and rail



4. Multi-body dynamics simulation of train overturns

Parameter of MBD simulation

Parameter of track

Parameters	Units	Value
Length of circular curve	m	192
Length of transition curve	m	60
Radius of circular curve	m	304
Super-elevation	m	0.097

Coefficient of friction between wheel and rail : 0.3

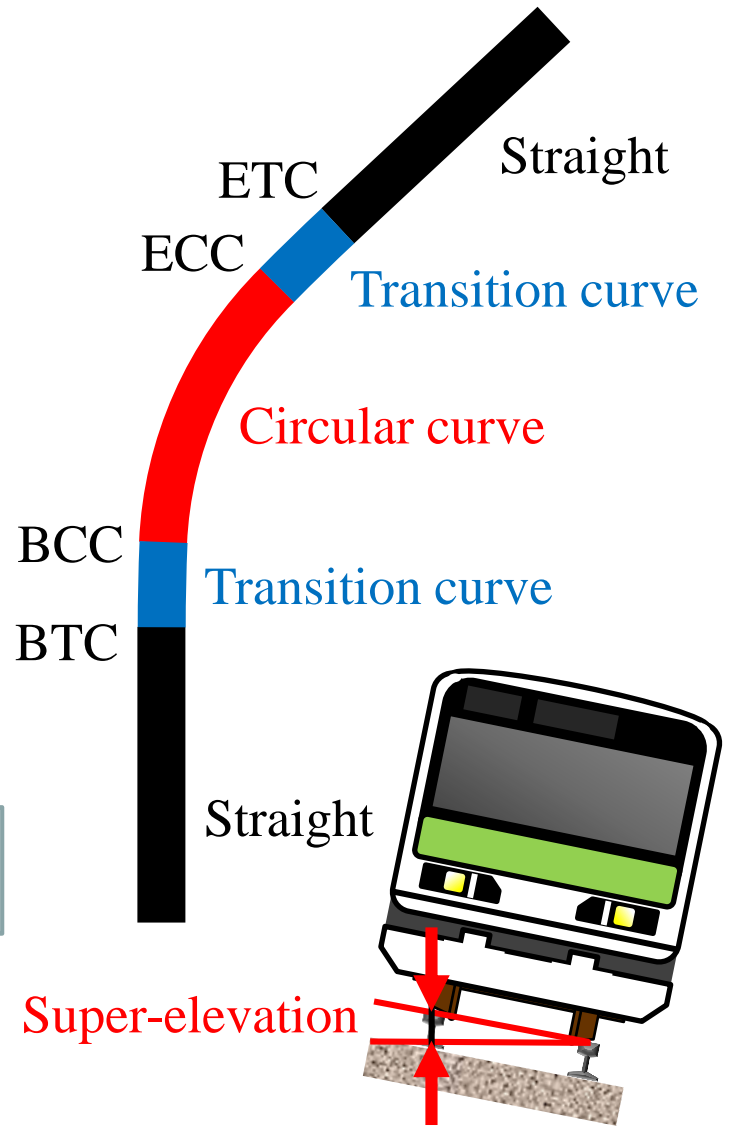

4. Multi-body dynamics simulation of train overturns

Criterion for judgment of overturning in the simulation

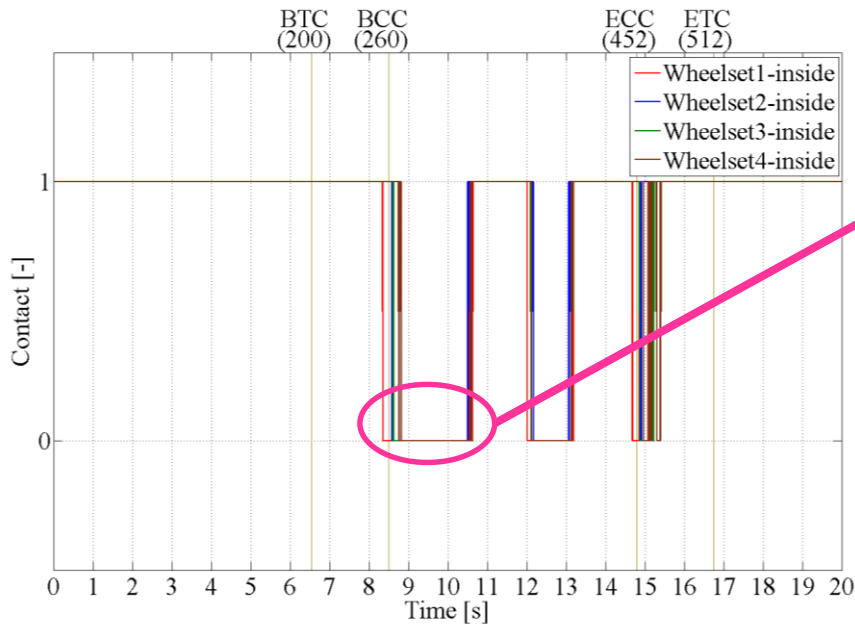
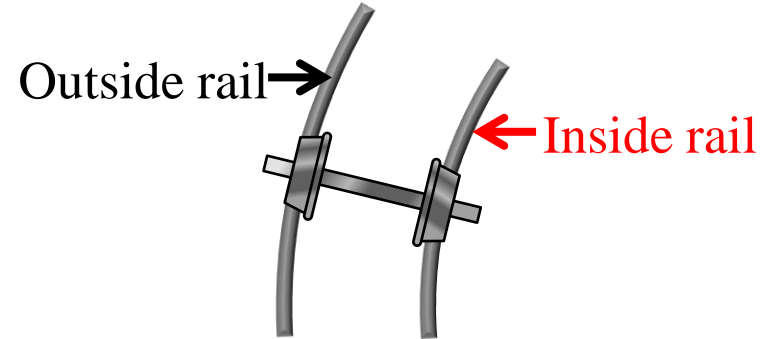
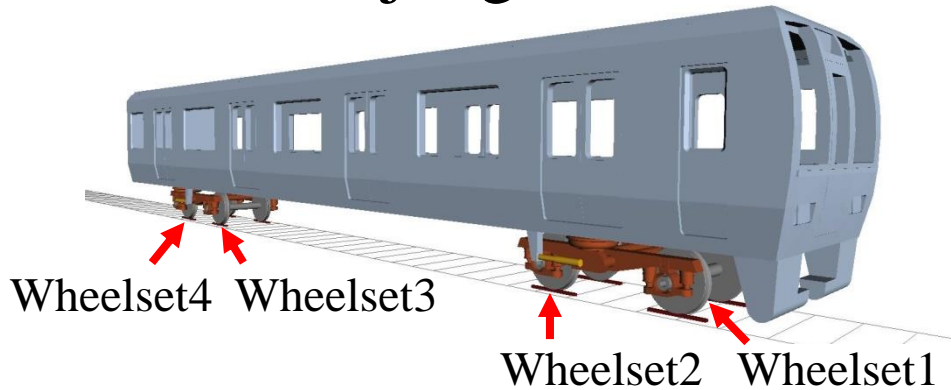

Four inside wheels doesn't contact with rail more than 1 sec.



Overturning

4. Multi-body dynamics simulation of train overturns

Animation by MBD simulation

Animation of overturning (Velocity: 111km/h)

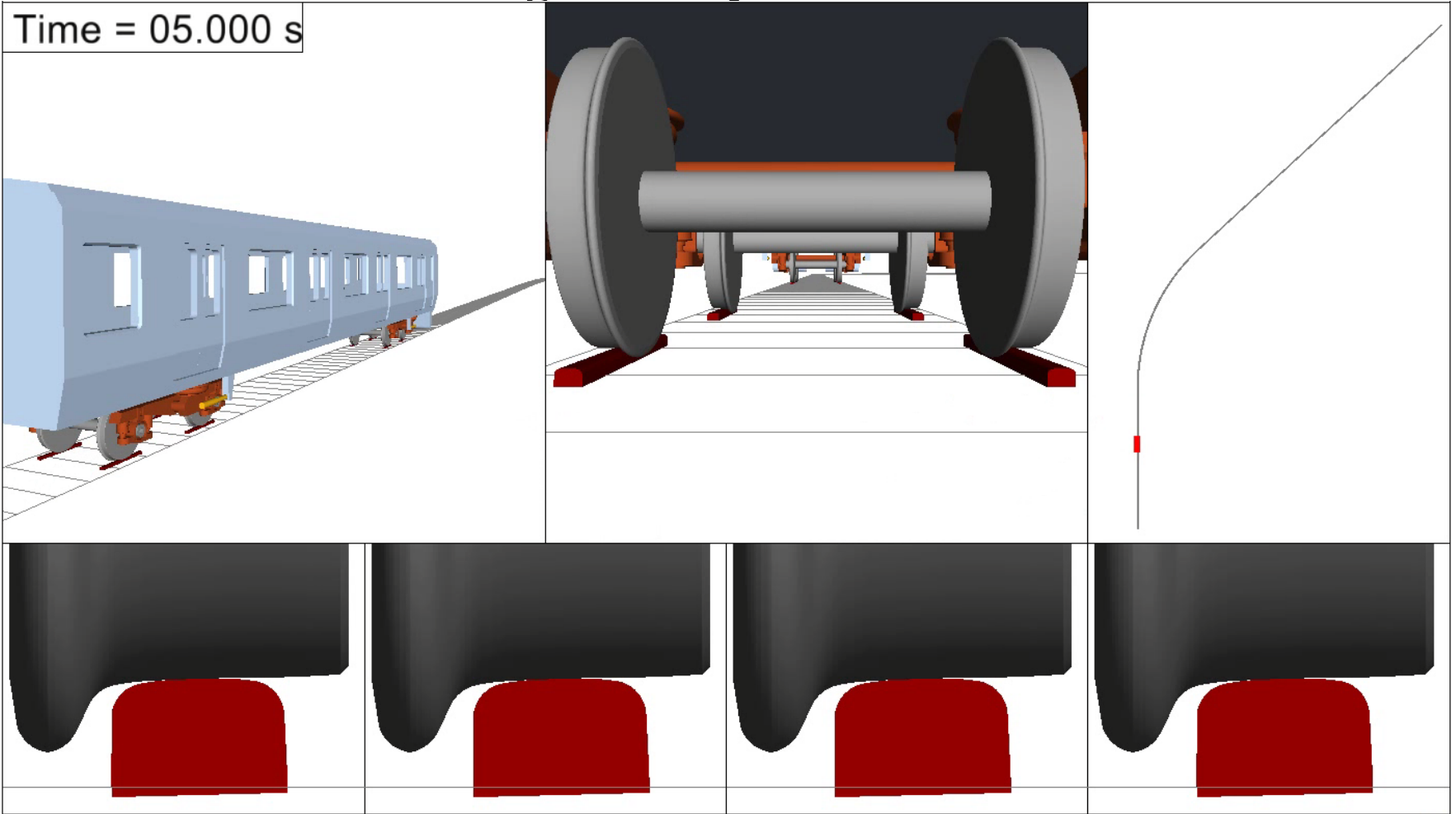

4. Multi-body dynamics simulation of train overturns

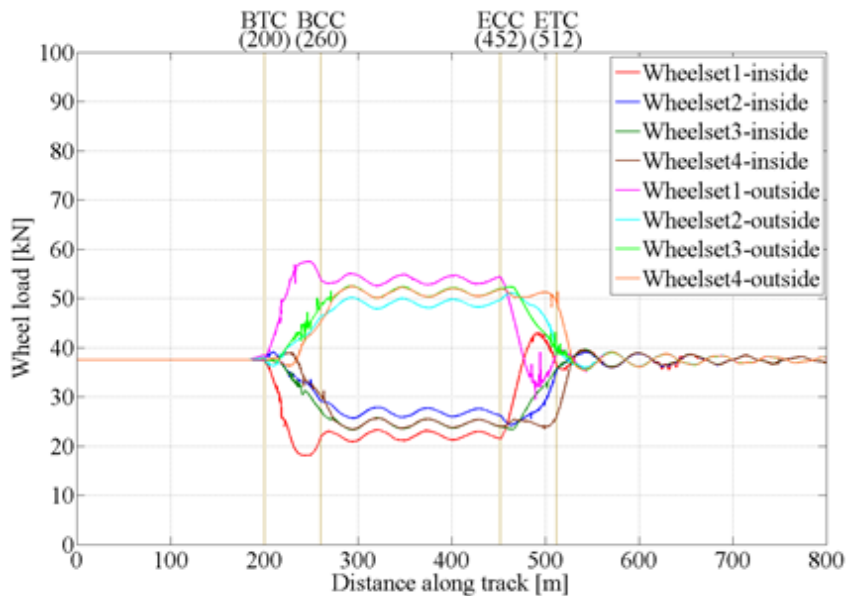

(a) $V=80$ km/h

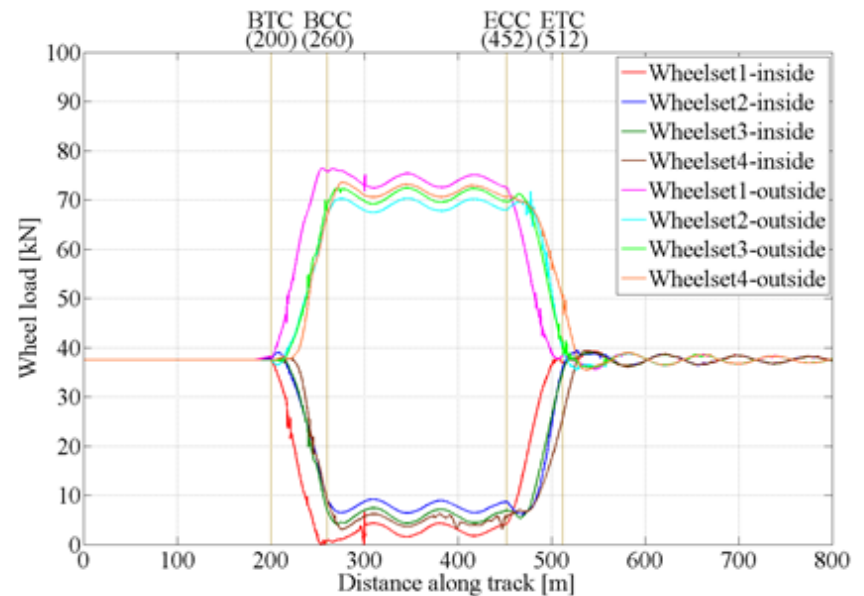

(b) $V=109$ km/h

Figure 9: Simulation results.

4. Multi-body dynamics simulation of train overturns

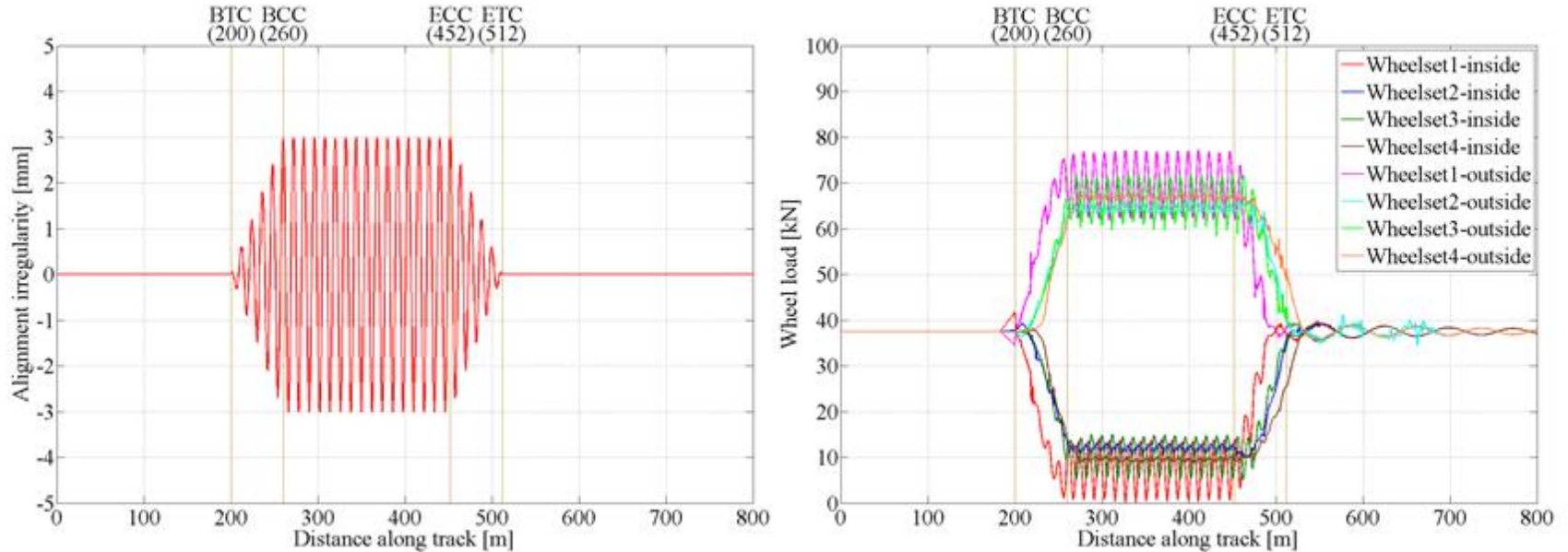

(a) Alignment irregularity

(b) $V=103$ km/h

Figure 10: Simulation results with track irregularities.

4. Multi-body dynamics simulation of train overturns

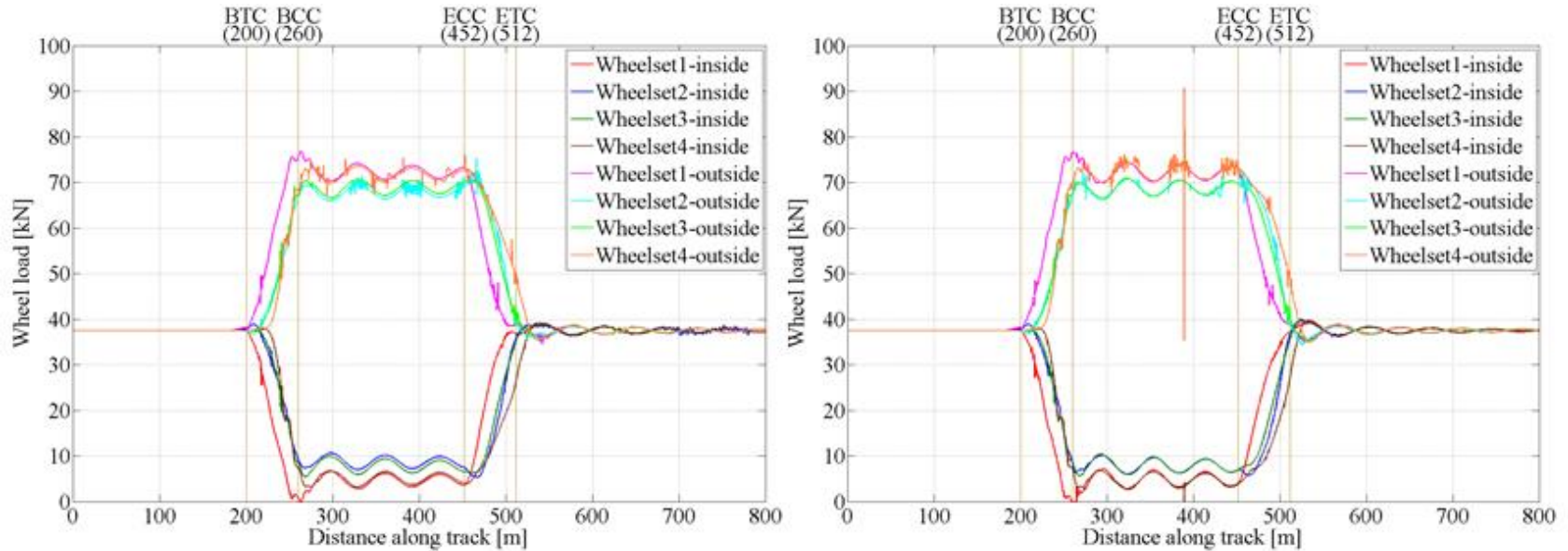

(a) Gauge=1.435 m at V=121 km/h

(b) Gauge=1.667 m at V=130 km/h

Figure 11: Simulation results.

4. Multi-body dynamics simulation of train overturns

Table 4 Comparison of Kunieda's formula and MBD simulation in critical speed against train overturn

Condition	Kunieda's formula	MBD simulation
Narrow gauge (1.067 m)	105.7 km/h	109 km/h
Standard gauge (1.435 m)	118.7 km/h	121 km/h
Wide gauge (1.667 m)	127.0 km/h	130 km/h

5. Considerations on the effect of related parameters

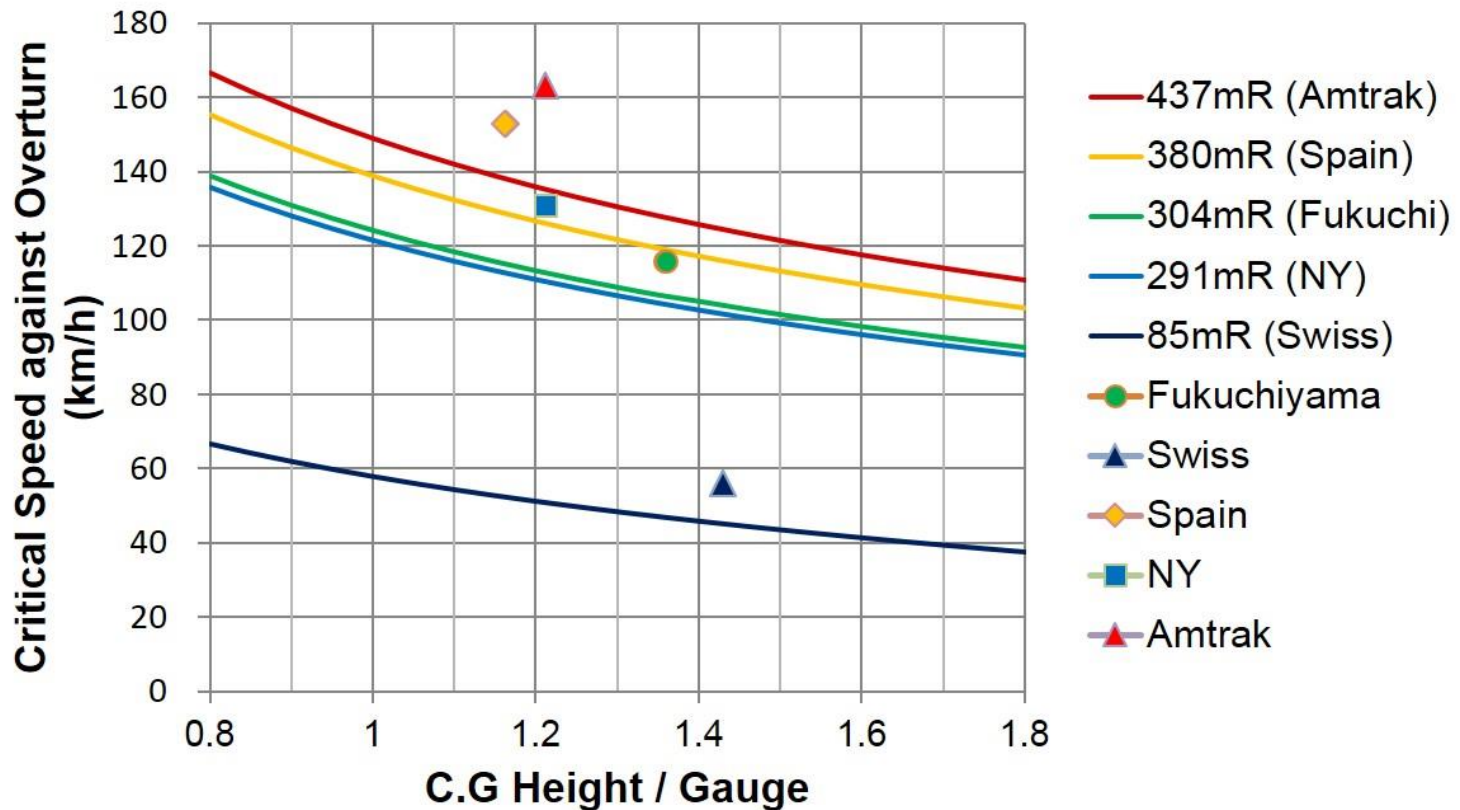

Figure 12 Overview of train overturn accidents.

5. Considerations on the effect of related parameters

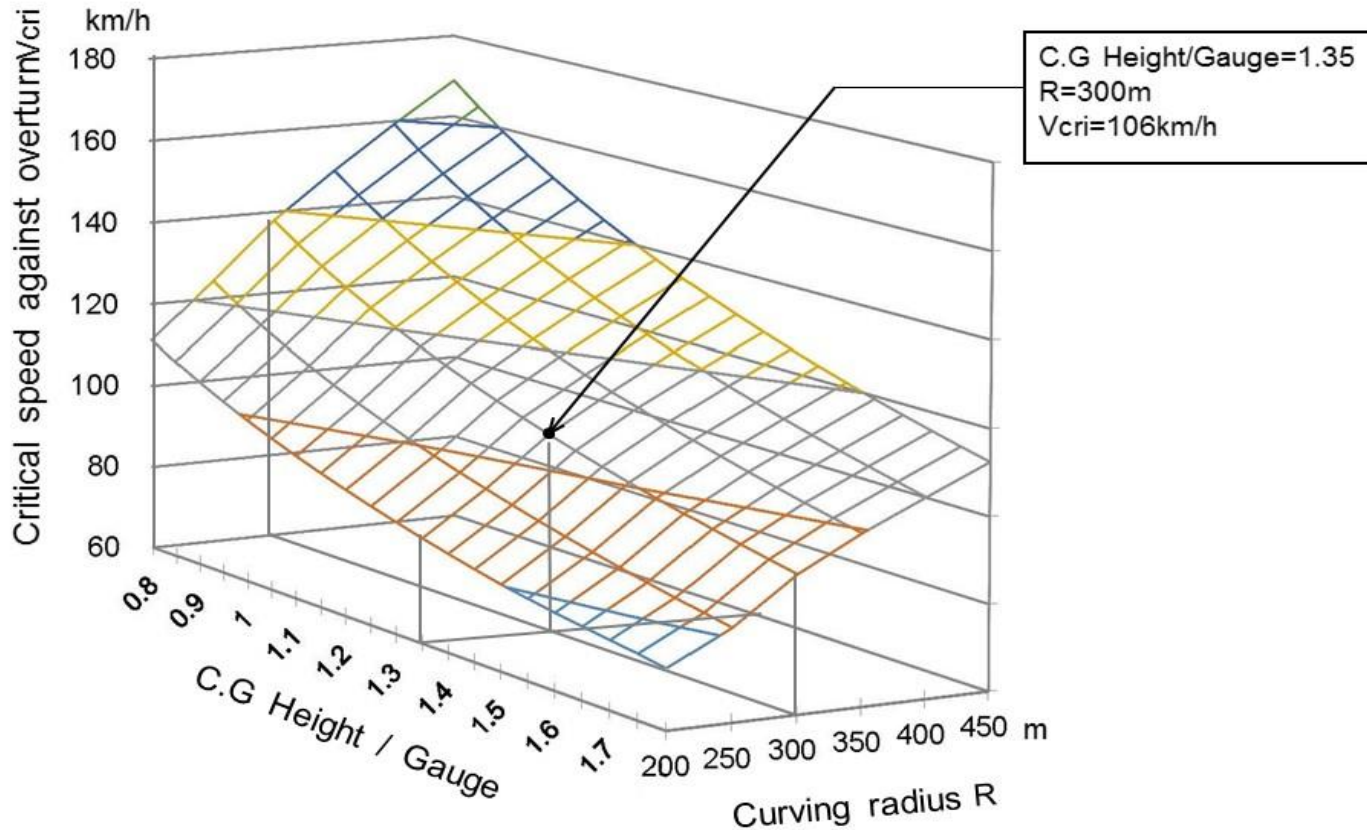

Figure 13 Overview of train overturn critical speed.

5. Considerations on the effect of related parameters

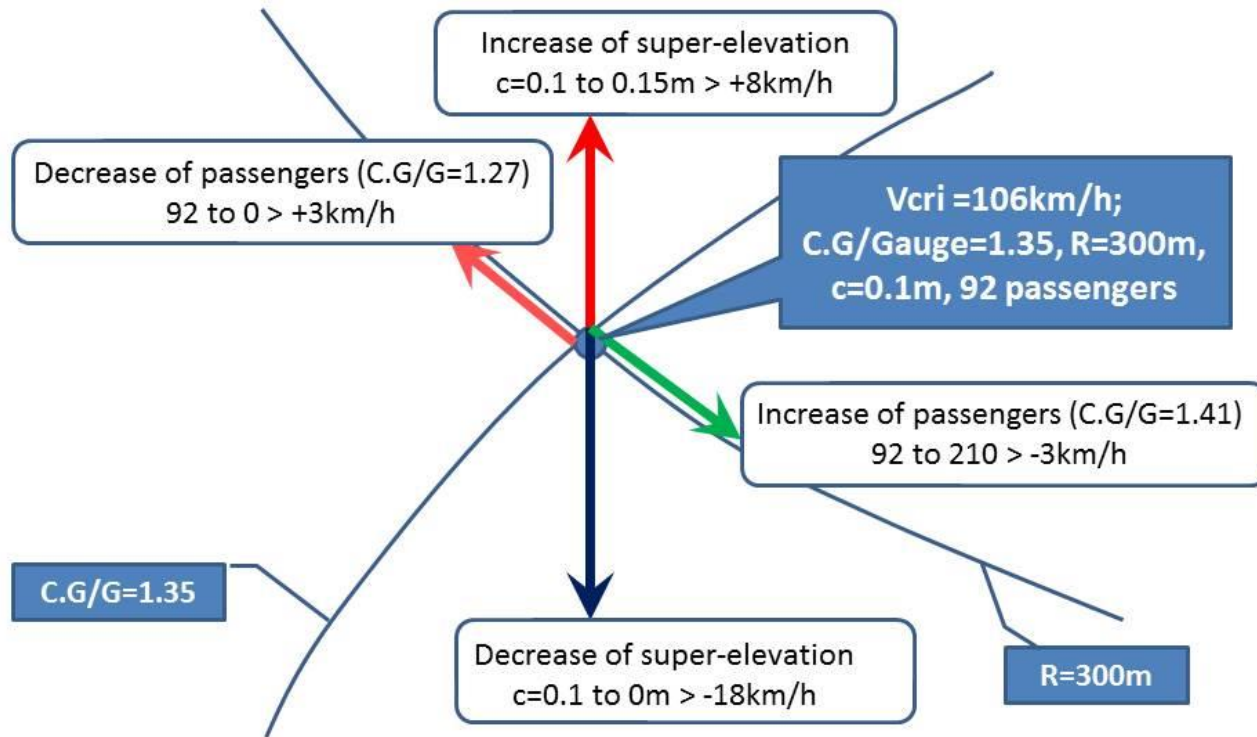

Figure 14 Influenced factors to train overturn critical speed.

6. Countermeasures for accident prevention

6.1 From technological aspects

The causes of the excess of curving speed were different among previous accidents.

For example,

- a) too early acceleration at the exit of curve (Glacier express),
- b) driver's snooze (NY Metro North),
- c) driver's misunderstanding of safety limit of curving speed (Spanish)
- d) braking delay (Fukuchiyama L.?).

It is important to take appropriate countermeasures for each cause, but it is also important to design vehicles and infrastructure, taking train running speed plan into consideration for securing the safety margin against train overturn.

6. Countermeasures for accident prevention

6.1 From technological aspects

The most effective prevention method for the train overturning is the prohibition of over-speed curving by signalling systems.

After the Fukuchiyama accident in 2005, **the Ministry of Transport Japan imposed the obligation to set up speed-detecting type ATSS at the entrance of sharp curves where the danger index D is more than 0.9 in Kunieda's formula** if the train entering the curve at the limit speed of the previous track section, which is normally tangent track.

Since the speed-detecting type ATS (ATS-P) or ATC systems had been established at most of required curves of main lines, no train overturn accidents have occurred in Japan.

6. Countermeasures for accident prevention

6.1 From technological aspects

In USA, NTSB declared the necessity of equipment of PTC (Positive Train Control) system, which is the advanced train control system including the prevention of excessive speed running, and recommended the introductions by 2015, but have not progressed yet.

After the accident of NY Metro North in 2013, FRA required New York MTA to establish the safety measures at curves where **the difference of speed limit to the previous section is more than 20 mph**. But the Amtrak accident happened in 2015 on a main line, and FRA required the **immediate setting of ATC** to Amtrak.

In Spanish case, there was no effective signalling system at the boundary between newly built high speed line and the conventional line.

Consequently **the immediate establishment of the speed-check-type automatic train stop systems are most desired, especially at the curves where extensive damage is predicted by risk assessments.**

6. Countermeasures for accident prevention

6.1 From technological aspects

The second most important factor is **the C.G height of vehicles**. The ratio of C.G height to gauge width deeply influences the critical overturn speed. **High C.G center height is an obvious disadvantage against overturn.**

The power unit coach in Spanish accident and the panorama coach in Glacier express are suspicious to concern the overturn. **The designing of lower C.G height vehicles is desired** considering passengers' weight.

6. Countermeasures for accident prevention

6.2 From human factors

Train drivers' education and training are also necessary and important.

According to the survey to train drivers of JR West after the Fukuchiyama accident, **more than half number of train drivers recognized that the limit speed against train overturn at accident site was higher than the accident speed.**

It is important for train drivers to learn the speed limit of curving of the train by schooling.

Results of questionnaire on **recognition of critical overturn speed to train drivers** of the Fukuchiyama line accident site

Critical overturn speed	No. of drivers (Percentage)	Cumulative percentage
$150\text{km/h} \leq v$	0 (0%)	0 %
$140\text{km/h} \leq v < 150\text{km/h}$	9 (18%)	18 %
$130\text{km/h} \leq v < 140\text{km/h}$	9 (18%)	36 %
$120\text{km/h} \leq v < 130\text{km/h}$	7 (14%)	50 %
$110\text{km/h} \leq v < 120\text{km/h}$	5 (10%)	60 %
$100\text{km/h} \leq v < 110\text{km/h}$	14 (28%)	88 %
$90\text{km/h} \leq v < 100\text{km/h}$	6 (12%)	100 %
$< 90\text{km/h}$	0 (0 %)	100 %

(The critical speed is calculated as 106-108 km/h)

7. Conclusions -analysis

The previous 5 serious “train overturn accidents” in past 10 years are considered.

“The leading vehicles of the train at the entrance of curve” or “the trailing vehicles of the train at the exit of curve” were overturned.

The high gravity center vehicles are easy to overturn.

In all accident sites **speed limit signalling devices had not been equipped.**

The phenomena of train overturning are considered by using the simplified Kunieda’s formula and SIMPACK simulation.

The calculated critical speed against train overturning is well agreed with each other, and **the Kunieda’s formula is practically effective in finding the critical speed of train overturn.**

The relationship between the critical overturn speeds and various parameters has been considered. **The critical speed is heavily influenced by the ratio of “C.G height of the vehicle” to “track gauge width”.** The overview of the critical speed changes against “**C.G Height/Gauge-ratio**” and “curving radius” are shown in the three dimensional graph.

7. Conclusions -countermeasures

The most effective method preventing train overturns is the prohibition of over-speed curving by signalling systems. The immediate establishment of **the speed-check-type automatic train stop systems** are most desirable, especially **at the curved section where extensive damage is predicted by risk assessments.**

The second most important matter is lowering the C.G height of vehicles because higher gravity center height is an obvious disadvantage against overturning.

Train drivers' education and training are also necessary and important in order to learn the speed limit of curving for trains driven by themselves in order to prevent extremely high speed curving.

Complementary remarks

It is very regrettable not to share the information of investigation results of the previous accidents in the world, and not to prevent recurrences of the same kind of accidents.

It is important to organize the basic concept of prevention of train overturn accidents for **the global collaboration in deriving teachings from accidents**.

Before finalizing this paper a very regrettable accident happened on the **SNCF TGV new line in November 14 of 2015**, where the train was running at 243 km/h and **derailed in 945m radius curve** of 176km/h limit speed. Causes are under investigation, but to prevent the recurrences of the same kind of accidents, the authors **think studies on the prevention of train overturning become more important**.

For the full paper,
visit the Saxe-Coburg Publications
“IJRT, Volume 5, Issue 2, Page 27-45, 2016”
<http://www.ctresources.info/ijrt/toc.html?id=18>