

AA2004-2

AIRCRAFT ACCIDENT INVESTIGATION REPORT

ASB FLYING CLUB
SUKHOI SU-26, RA2821K
A CRASH TO THE GROUND
AERIAL CIRCUIT IN MOTEGI TOWN, HAGA COUNTY,
TOCHIGI PREFECTURE, JAPAN
OCTOBER 31, 2003

July 30, 2004

Aircraft and Railway Accidents Investigation Commission
Ministry of Land, Infrastructure and Transport

The investigation for this report was conducted by Aircraft and Railway Accidents Investigation Commission, ARAIC, about the aircraft accident of ASB FLYING CLUB SUKHOI SU-26 in accordance with Aircraft and Railway Accidents Investigation Commission Establishment Law and Annex 13 to the Convention of International Civil Aviation for the purpose of determining cause of the aircraft accident and contributing to the prevention of accidents and not for the purpose of blaming responsibility of the accident.

This English version report has been published and translated by ARAIC to make its reading easier for English speaking people those who are not familiar with Japanese. Although efforts are made to translate as accurate as possible, only the Japanese version is authentic. If there is difference in meaning of the texts between the Japanese version and the English version, texts in the Japanese version are correct.

Junzo Sato,
Chairman,
Aircraft and Railway Accidents Investigation Commission

AIRCRAFT ACCIDENT INVESTIGATION REPORT

ASB FLYING CLUB

SUKHOI SU-26, RA2821K (RUSSIAN REGISTRATION)

A CRASH TO THE GROUND AT AERIAL CIRCUIT IN MOTEGI TOWN, HAGA COUNTY, TOCHIGI PREFECTURE, JAPAN AT AROUND 10:31 JST, OCTOBER 31, 2003

1. THE PROCESS AND PROGRESS OF THE ACCIDENT INVESTIGATION

1.1 Summary of the Accident

On Friday October 31, 2003, a Sukhoi Su-26, RA2821K belonging to the ASB Flying Club was taking part in an air show held at the Twin Ring Motegi Auto Race Circuit in Motegi Town, Haga County, Tochigi Prefecture. The aircraft took off from the circuit's airstrip with the Captain the only occupant, and was flying inverted along an air race competition course when at around 10:31, it deviated from the course, collided with a flood light stay and other objects near the left of the course, and crashed.

The sole occupant of the aircraft, the Captain, sustained serious injuries.

The aircraft was severely damage, but there was no fire.

1.2 Outline of the Accident Investigation

1.2.1 The Organization of the Investigation

On October 31, 2003, the Aircraft and Railway Accident Investigation Commission (ARAIC) assigned an investigator in charge and two investigators.

1.2.2 Accredited Representative and Specialist in Foreign State

Although the accident was notified to the Russian Federation, the state of registration, design and manufacture of the aircraft, the Russian Federation did not appoint a representative.

1.2.3 The Implementation of the Investigation

October 31, and November 1, 2003	Interviews and on-site investigation
November 20, 2003	Interviews
December 5, 2003	Interviews

1.2.4 Hearings form the Persons relevant to the Cause of the Accident

A hearing are planned to gather opinions from a person connected with the cause of the accident.

2. FLIGHT HISTORY

2.1 The Progress of the Flight

On October 31, 2003, a Russian Federation-registered Sukhoi Su-26, RA2821K, owned by the ASB Flying Club (Note 1), was scheduled to take part in a time challenge competition to fly around ten poles at the Twin Ring Motegi Auto Race Circuit as part of an air show.

The air show was scheduled to be held over three days, and the time challenge competition was planned with practice flight on the first day and with the competition heats to be held on the second and third days. Eleven participants (eleven aircraft) were planned to take part. The accident occurred on the first (practice) day and the aircraft's Captain was the first of the eleven participants to fly.

The competition course had two "gates" where a tape is stretched between a pair of poles either side of the course. The tapes were to be cut by contact with the aircraft passing through the gates. The aircraft were to pass through one gate in a normal flight attitude, to pass through the other gate inverted, and having passing through each gate the aircraft were to climb vertically, roll and turn to change heading through 180 degrees (similar to a stall turn).

A summary of the progress of the flight compiled from video recordings made by the company that held the air show (the sponsor) and persons connected with the air show is as follows:

The aircraft took off the Twin Ring Motegi airstrip at the Twin Ring Motegi Auto Race Circuit at 10:27 with only the Captain on board, and after adjusting time in the air, entered the time challenge competition course at 10:29.

After succeeding in cutting the first tape by passing through the gate in a normal flight attitude, the aircraft performed vertical reverse and then made a steep descent to enter the course for the next gate to cut the tape in inverted flight (Refer Figure 1 (7).)

After entering the course, when the aircraft had rolled inverted in level flight and was wings level, after the aircraft's right wing lowered (viewed from behind) and it moved to the right side of the course, then its left wing lowered and its flight direction changed from rightwards to leftwards (viewed along the course centerline). The aircraft began to climb as its left wing lowered and then just before the gate it began to descend.

Because the aircraft flew diagonally across the course to the left with its left wing lowered and it continued to descend after passing through the gate, the aircraft collided with a flood light stay and other obstructions located around 60m from the left pole of the gate in the direction of travel while inverted and crashed.

The accident occurred at around 10:31.
(Refer to Fig. 1 and Photographs 1, 2, 3, 4, 5.)

Note 1: The name of the belonging party of the aircraft is the name of the group described

in the certificate of registration issued by the Russian Federation.

2.2 Fatalities or Injuries to Persons, or Missing Persons

The Captain of the aircraft sustained serious injury.

2.3 Damage to the Aircraft

2.3.1 Extent of Damage

The aircraft was severely damaged.

2.3.2 Damage to Aircraft by Part

Fuselage:	Damaged
Wings:	Right wing: broken at the mid span and at the root Left wing: severed at the root.
Vertical stabilizer:	Broken off at the root and at upper portion.
Propeller:	All three wooden propeller blades were destroyed, breaking into small fragments.
Landing gear:	The right main gear was severely damaged by bending. The tail wheel was damaged.

2.4 Damage to Other than the Aircraft

A flood light stay, a light signal stay and the roof of a small observation building were damaged.

2.5 Crew Information

Captain:	Male, aged 35	
Russian Federation Commercial Pilot License (Airplane)		
Term of validity		Until March 3, 2004
Russian Federation Airman's Medical Certificate		
Term of validity		Until April 4, 2004
Total flight time		approx. 2,000 hours
Flight time during the previous 30 days		unknown
Total flight time on same type of the aircraft		unknown
Flight time during the previous 30 days		unknown

(The above flight times are according to the captain's statements.)

In connection with the air show, the Captain had obtained an approval to fly an aircraft

under Civil Aviation Law Article 28 Paragraph 3.

2.6 Aircraft Information

2.6.1 The Aircraft

Type:	Sukhoi Su-26
Serial No.:	05-06
Date of manufacture:	October 1, 1991
Russian Federation Certificate of Airworthiness:	No. 7443
Term of validity:	March 31, 2004
Russian Federation Aircraft Category:	Aerobatic
Total flight time:	119 hours 15 minutes
Flight time since time last check (3-monthly periodic check on August 21, 2003):	0 hour 50 minutes

In connection with the air show, the aircraft had been issued an exemption approval under Civil Aviation Law Article 11 Paragraph 1.

2.6.2 The Engine

Type:	Vedeneyev M-14P
Serial No.:	112028
Date of manufacture:	February 28, 1991
Total time in service (Refer to Fig. 4.)	320 hours 21 minutes

2.6.3 Weight and Center of Gravity (CG)

The weight of the aircraft at the time of the accident is estimated to have been approximately 795kg, within the allowable range (maximum take-off and landing weight: 835kg). There were no records of the CG position.

2.6.4 Fuel and Lubricating Oil

The fuel on board was AVGAS-100. The lubricating oil was Aero Shell W-100.

2.7 Meteorological Information

According to the person responsible for communications during take-off and landing, the weather at the Twin Ring Motegi airfield at the time of the accident was as follows:

Wind direction: 180°, Wind speed: 2kt, Visibility: greater than 10km, no cloud.

2.8 Information on the Accident Site and Aircraft Wreckage

2.8.1 The Accident Site

The accident site was located in the Twin Ring Motegi Auto Racing Circuit. Two of the four lights on the flood light stay which the aircraft collided with were damaged, and the arm to which the lights were attached was rotated 180 degrees horizontally. A signal pole located around 2m from the lighting pole's course side was slightly inclined in the aircraft's direction of travel, part of the roof of a neighboring observation building was damaged and a horizontal stabilizer had fallen near the observation building. There were several score marks on the asphalt surface of the racetrack caused by propeller strikes around 50m from the observation building in the aircraft's direction of travel. Traces attributed to collision with aircraft's nose and canopy were found on the shock-absorbing crash barrier made of piled tires that surrounds the racetrack around 100m from the observation building in the aircraft's direction of travel.

The aircraft's fuselage came to rest around 5m in front of the crash barrier, and the left wing separated at the root and came to rest around 10m from the fuselage in the aircraft's direction of travel. The wooden propeller was broken into small fragments, and aircraft debris was scattered over an area around 35m wide and around 75m long in the direction of travel from near the flood light stay.

The inverted flight portion of the air race course was set to be 200m away from the stand of the circuit.

(Refer to Fig. 2)

2.9 Medical Information

According to the Motegi Police Office of Tochigi Prefecture, the pilot sustained serious injuries including fractures of lumbar vertebrae etc.

2.10 Information on Search, Rescue and Evacuation relevant to Survival, Death or Injury

After the accident, the Captain was carried in a helicopter used for sight-seeing flight for the air show and was admitted to hospital in Mibu Town, Tuga County, Tochigi Prefecture at 11:17.

2.11 Analysis of the Flight

The following is the result of an analysis of the progress of the flight based on video recordings and still photographs taken by the sponsor.

The analysis begins at 1030:39, the time the aircraft entered the inverted flight part of the air race course (here in after [the course]) from a vertical reverse. The course was in an approximately 500m long, 23m wide strip of airspace set above a 13m wide paved road

and two 5m wide non-paved zones on either side of the road. “Gates” established at either end of this part of the course consisted of a white paper tape stretched between the tips of two poles either side of the course at a height of 9.8m above the ground.

The aircraft entered the course just above the centerline of paved road at a height of around 9.8m above the ground. The aircraft rolled to the right at 1030:40, and became inverted at 1030:40.5, at which time it was around 10m above the ground. Viewed from behind, once the aircraft had become inverted the right side wing lowered and it started to deviate right of the course centerline. At 1030:42.0, viewing along the direction of travel, the aircraft entered the non-paved zone at the right side of the road, and after rolling back to wings level, the left side wing lowered viewed from behind the aircraft, and at a time the aircraft started to climb. At 1030:43.4 the aircraft reached an altitude of around 20m above ground.

Thereafter, the aircraft started to descend with the left side wing lowered viewed from behind from around 60m before the gate, and at 1030:44.3, it passed over the tape stretched 9.8m above ground at the gate slightly to the left of the course centerline. The aircraft continued descending after passing the gate with the left side wing lowered (viewed from the rear), flew diagonally across the course and deviated from the course to the left. Although the aircraft’s nose lifted just before the lighting pole, at 1030:44.9 its right wing struck the flood light stay at a height of 5.6m above the ground a distance of 60.5m from left side pole exit gate pole in the direction of the travel. The root of the tail wing then collided with a 5m-high light signal stay, and the aircraft crashed.

The aircraft’s average airspeed during the time from level flight before starting to roll until striking the flood light stay was 270km/h (approx. 75m/s), the time between starting to climb until the first collision was around 2.8 seconds, and the flight distance was around 200m.

(Refer to Fig. 3)

2.12 Other Information

2.12.1 Permissions concerning Civil Aviation Law

(1) Applications had been made for the necessary permissions to fly at the air shows under Civil Aviation Law — permission under Article 81 (Minimum safety altitude) and exemption under Article 91, paragraph 1 (Aerobatic flight) — under the following conditions, and the permissions had been granted.

① Minimum safety altitude Purpose: To conduct an exhibition flight (Note 2)

Altitude: Altitude less than 100 ft above the ground

② Aerobatic flight Purpose: To conduct aerobatic flight at the Air Show

Altitude: Altitude above ground of 100–4000 ft

(Note 2) Details of the exhibition flight were not described in the application. According to the statement from the applicant, the exhibition flight referred to an opening flight and a straight fly-pasts after an aerobatic flight

competition.

- (2) Regarding to the tape cut in inverted flight under the time challenge competition, since inverted flight comes under aerobatic flight and the tape cutting was to be made at a flight altitude of around 10m (around 30ft), it was found that these flight conditions were not in accordance with the conditions of the aerobatic flight permission.

According to the statements of persons concerned with the air show, the time challenge competition was designed by a representative of the company that planned the air show, and this was the first time the event was to be held. Although the sponsors and the agent who applied for the permits had several meetings with the planning company to grasp the flight details of the time challenge competition, they did not realize until it was pointed out after the accident that the time challenge competition met the criteria for aerobatic flight, and they thought it could be conducted as an exhibition flight. Because of this, details relating to the flight air space of the time challenge competition were not included in the aerobatic flight application for the air show.

2.12.2 The Statements of the Pilot who had flown in the Aircraft before the Accident and the Representative of the Planning Company

- (1) The pilot who had flown in the aircraft before the accident

“I made a total of four flights with the aircraft: a confirmation flight after assembly of the aircraft on October 29, a time challenge practice flight on the morning of the 30th, a free style practice flight on the same afternoon, and an opening flight on the 31st, the day of the start of the air show. There were no especial problems on these flights, and after landing of the opening flight on the 31st, I commented to the engineer that there were no problems with the condition of the aircraft, and made the same comments to the Captain of the aircraft.

“I didn’t think there were any problems with the time challenge competition course. I was aware of the signal pole located beyond the 7th pole and I judged it difficult but acceptable. I also flew six laps of the course during preliminary practice without problem.

“The Captain flew five to six laps of the course during practice for the time challenge competition on the morning of the 30th.

- (2) The representative of the planning company which planned the competition and established the course

“This was the first competition of time challenge in the world, consisting of a race around some poles combined with aerobatic flight of loops and vertical rolls. There were no problems in establishing the course. I made a preliminary walk-through of

the course on foot with all of the participating pilots and persons concerned and I asked their advices. Then the heights of the 7th pole at which the tape was to be cut inverted and poles in two other places were raised from 6m to 10m in order to make the poles easier to distinguish.

Since the tapes were extended 10m high above the ground level, the flood light stay and other obstructions were lower than the height of the tapes. The pilots made no particular comments regarding these objects relating to the accident occurred. On the morning on 30th, all the pilots each flew three practice laps of the time challenge competition, and as a result I decided that the time challenge competition could be held.

Any problems with the physical condition of the participating pilots or with the aircraft were to be reported, and there were no such reports before the accident.

2.12.3 The Air Show Operating Organization and the Operating Management

(1) The air show operating organization

The sponsor carried out the management of whole the air show, except the planning company planned the flight details for the participating aircraft, and a representative of the planning company assumed overall responsibility for all flight-related matters.

The planning company's representative delegated an agent as a deputy to handle applications relating to Japanese Civil Aviation Law.

(2) Emergency Measures

The sponsor established a crisis center to deal with any accident that might occur. A systematic chart containing directions and commands to respond to emergencies was developed, and training exercises were conducted before opening the show.

According to the statements of the persons related to the air show, this organization functioned adequately and responded smoothly.

(3) The Operation of Aircraft at the Air Show

Aircraft operations at the air show were conducted under the operating standards that had been established by the sponsor. According to the statements of persons connected with the air show, aircraft operations were to be carried out following the operating standards, and as specified in the rules, on the morning of the day of the accident the representative of the planning company, who was supervising flight, briefed all pilots. There were no reports of bad health of the pilots from the accompanying medical staff.

(Refer to the attached "Operating Standard (Extract)")

2.12.4 The Captain's Aerobatic Flight Competition Experience

According to information from the sponsor, the aerobatic flight competition experience of the Captain was as follows:

- (1) 1988: Began to participate in aerobatic flight competitions.
- (2) 1999: Won a silver medal in the Europe Championship Competition for Aerobatic Flight.
- (3) Won a silver medal participating as a member of the Russian team in the World Championship Competition in 2000.
- (4) Was provisionally ranked overall 3rd in aerobatic grand-prix competitions in 2003 before the accident.

3. ANALYSIS

3.1 Analysis

3.1.1 The Captain had obtained a permit for pilot proficiency under Article 28, paragraph 3 of Civil Aviation Law. The Captain had valid aircrew proficiency certificates and a valid aircrew medical certificate, all issued by the State Civil Aviation Authority of Russia.

3.1.2 An airworthiness permit for the aircraft had been obtained under an exemption of Article 11 Civil Aviation Law, and the aircraft had been maintained and inspected as specified by applicable regulations. Judging from the flight condition of the aircraft just before the accident, it is considered that there were no abnormalities in the aircraft system and engine until the accident occurred. Regarding the position of the center of gravity, the aircraft was fully loaded with fuel at take-off, and it is estimated that the shift of CG position due to the consumption of fuel from the fuel tank near the wing spar was small, and that the aircraft's center of gravity was within limits.

The aircraft had a valid certificate of airworthiness issued by the State Civil Aviation Authority of Russia.

3.1.3 It is estimated that the weather conditions at the time of the accident had no bearing on the occurrence of the accident.

3.1.4 As described in section 2.11, the aircraft performed vertical reverse and entered the course in level flight just above the course centerline, and then become inverted by rolling to the right. It is estimated that the aircraft deviated to right from of the course centerline at that time because the right side wing was lowered (viewed from rear). After that, it is estimated that the aircraft recovered to wing levels and then in order to align with the course, the left side wing was lowered (viewed from rear), and at the same time the aircraft started to climb.

The aircraft climbed to a height of around 20m while flying inverted from the right to the left of the course. After that, it is estimated that the Captain sighted the target tape in front of him and aiming for it, he descended while flying diagonally across the course.

At the time the aircraft entered the course it was flying level at a height of around 10m above the course centerline. Although the aircraft should have then maintained this height, as a result of considering that it then climbed to a height of 20m against the Captain's first intention, it is estimated that the Captain made an abrupt descent in order to cut the tape stretched at a height of 11m above ground in front of him. Moreover, regarding the fact that the aircraft descended while flying across the course in a banked

attitude, it is estimated that because the Captain was concentrating on cutting the tape, he had reduced awareness that the aircraft was banked and deviating to the left.

It is estimated that because the aircraft had deviated to the left of the course as a result of flying across the course in a banked attitude, and because it was in a steep descent attitude just before the tape, the Captain raised the aircraft's nose in front of the lighting pole, but it was too late and the aircraft collided with the flood light stay, which was 5.4m lower than the poles from which the tape was stretched, and other obstructions near the left of the course, in inverted flight and crashed.

(Refer to Figs. 1 and 3, and Photographs 1, 2, 3 and 5.)

3.1.5 As described in the section 2.12.2, since all of the pilots who participated in the time challenge competition, including the Captain, had looked over the course on the ground and had made several practice flights the day before, it is estimated that the Captain had grasped the course conditions, including the existence of the flood light stay and light signal stay. Further, given that Captain had achieved good results in aerobatic flight competitions at many air show locations before this air show, it is estimated that there were no problems with his aerobatic flying skills.

However, for the tape cut in inverted flight event, there is a risk that the slightest maneuver may cause deviation from the course and extremely high levels of skill and concentration are required. After the aircraft had climbed to a height of around 20m, regarding the Captain did not abandon the tape cut but descended for the tape while flying across the course in a banked attitude, it is considered that this was because he was strongly determined not to fail to cut the tape, being the first participant in the competition watched by a large audience, and because he was concentrating on cutting the tape, it is considered possible that he momentarily lost awareness of the aircraft's attitude.

Even in an air show competition, it is considered that when it becomes difficult to achieve a task in an event such as the tape cut, to ensure flight safety it is important to abandon the task without hesitation and to achieve safe flight. To achieve this, it is considered that it will be effective to discuss beforehand the rules for abandoning a task due to deviation from the course.

3.1.6 Applications and Permits related to Civil Aviation Law

Regarding the inverted flight tape cut in the time challenge competition, because inverted flight is applicable to an aerobatic flight condition and the flight altitude at the tape cut was set at around 10m (30ft) above the ground, it is considered that the flight was conducted under conditions that were not in accordance with the limits of the aerobatic flight permit.

Regarding these matters, as described in subsection 2.12.1(1), the persons concerned with the air show did not recognize that aerobatic flight regulations of Civil Aviation Law were applicable to the flight events in the time challenge competition. It is estimated that as a result of this, details of the time challenge airspace were omitted from the permit application for the time challenge competition.

When the air show is held, it is necessary to give adequate consideration of the flight details, to include all the air show events in the applications for the relevant permits under Civil Aviation Law, and to keep within the limits of the permits.

4. PROBABLE CAUSE

It is estimated that this accident was occurred when the aircraft aimed for the low-stretched tape in inverted flight during a competition, and because it was flying across the course while descending, the aircraft deviated to the left of the course, collided with an adjacent flood light stay and other objects and crashed. The Captain sustained serious injuries and the aircraft was severely damaged.

Photograph 1 Immediately before the Collision



Photograph 2 Immediately after the Collision



Photograph 3

Flood light stay
Light signal stay
Observation building

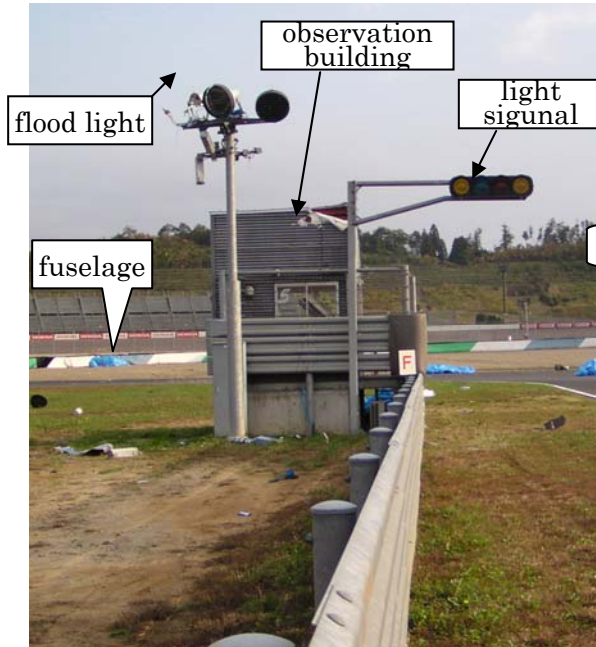

Photograph 4

Score marks
by propeller

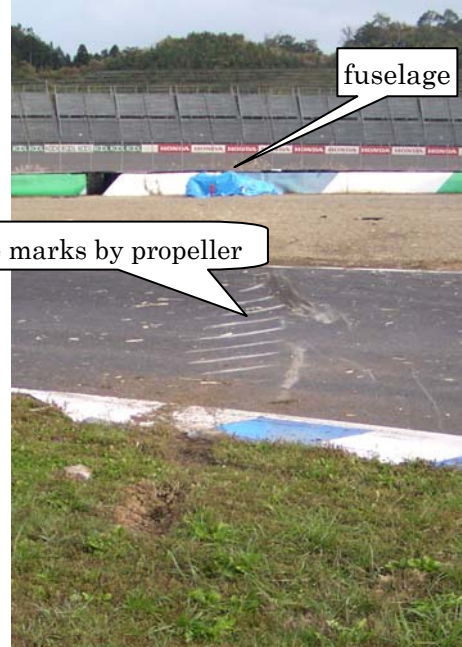

Photograph 5 Accident aircraft(Fuselage)



Figure1 Estimated Flight Path

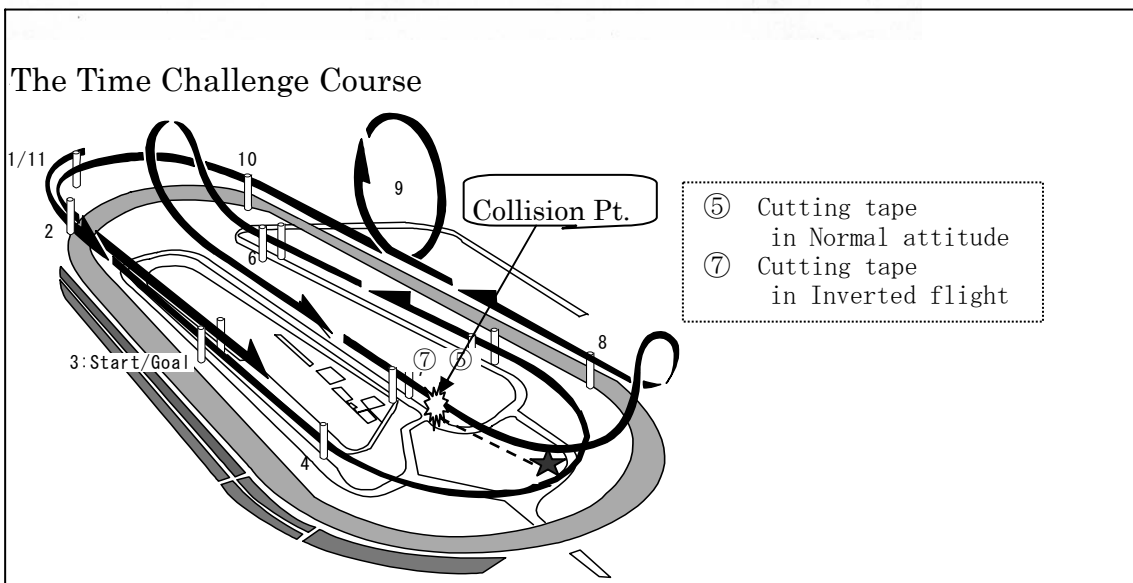
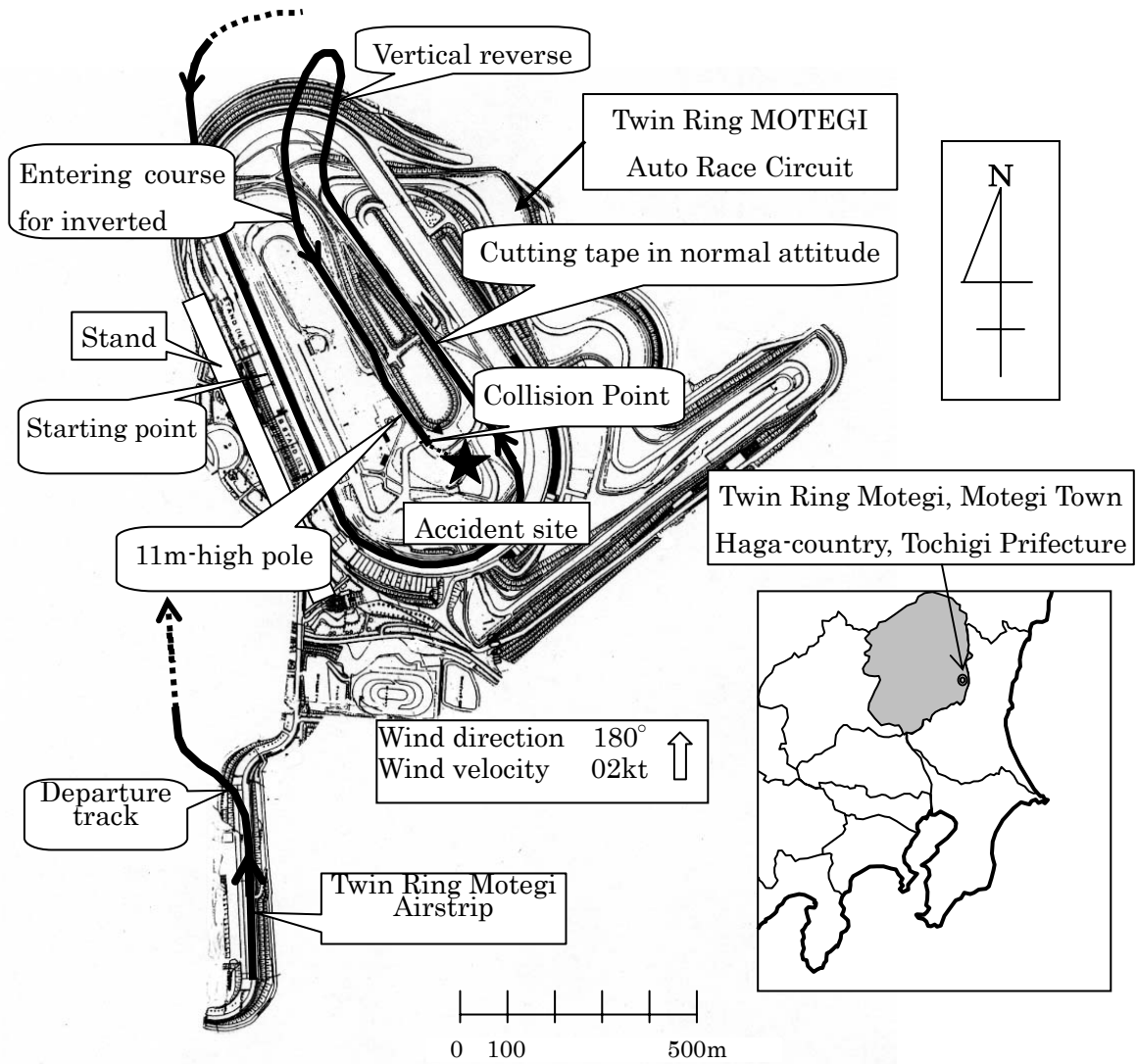

Figure 2 Topography of the Accident Site

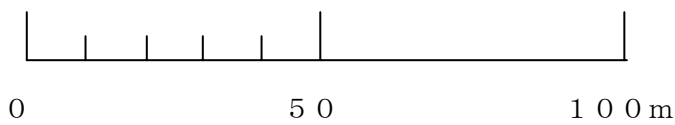
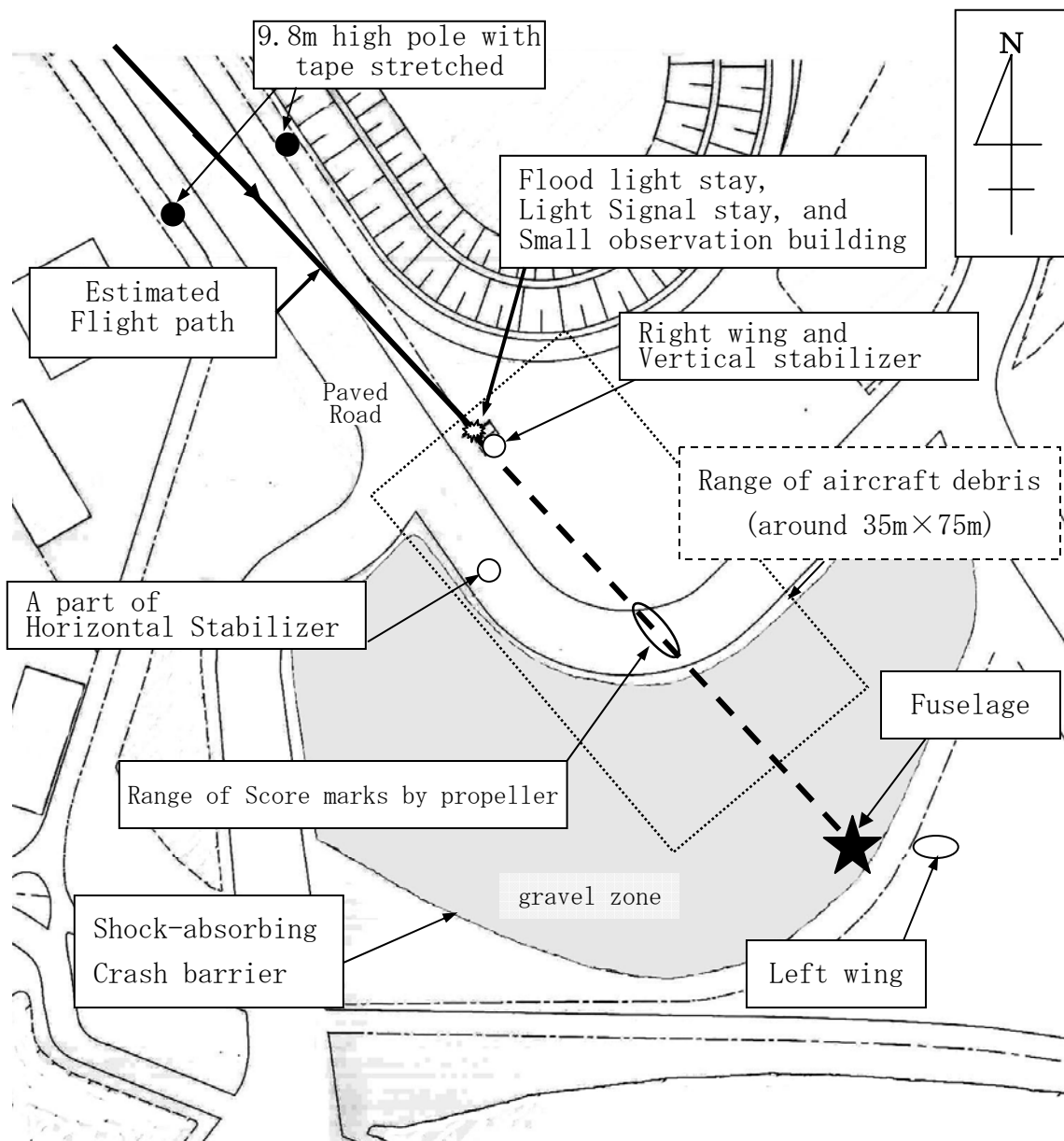
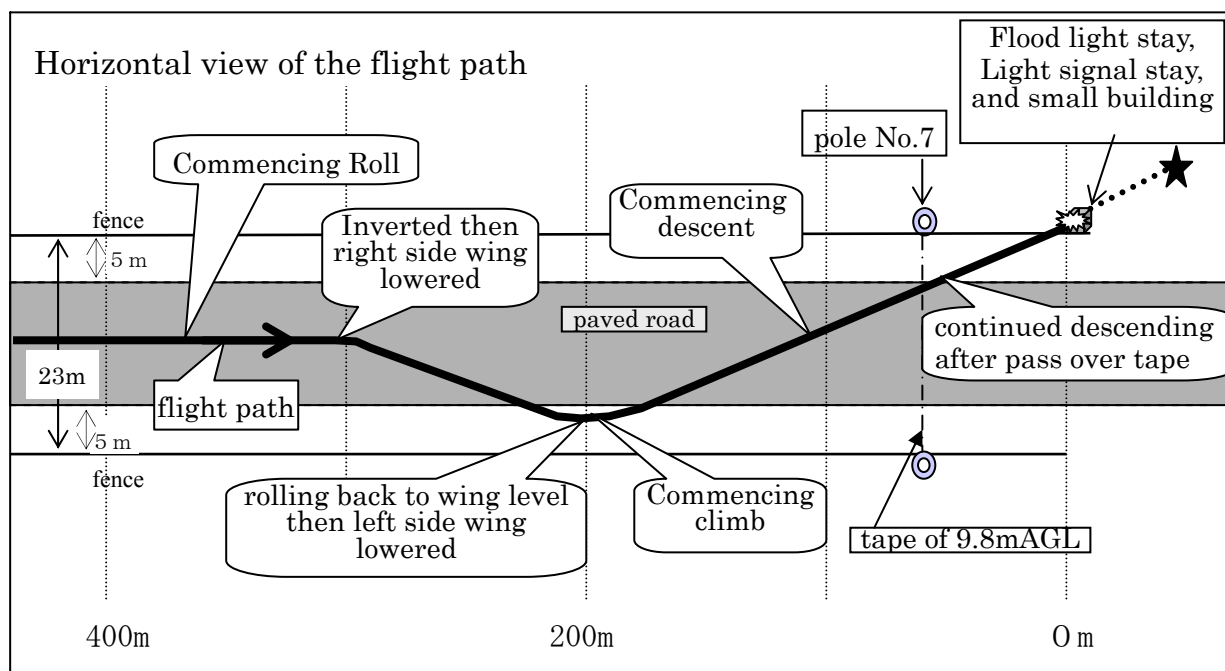
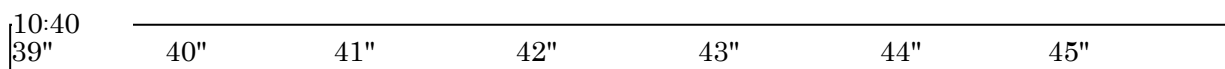
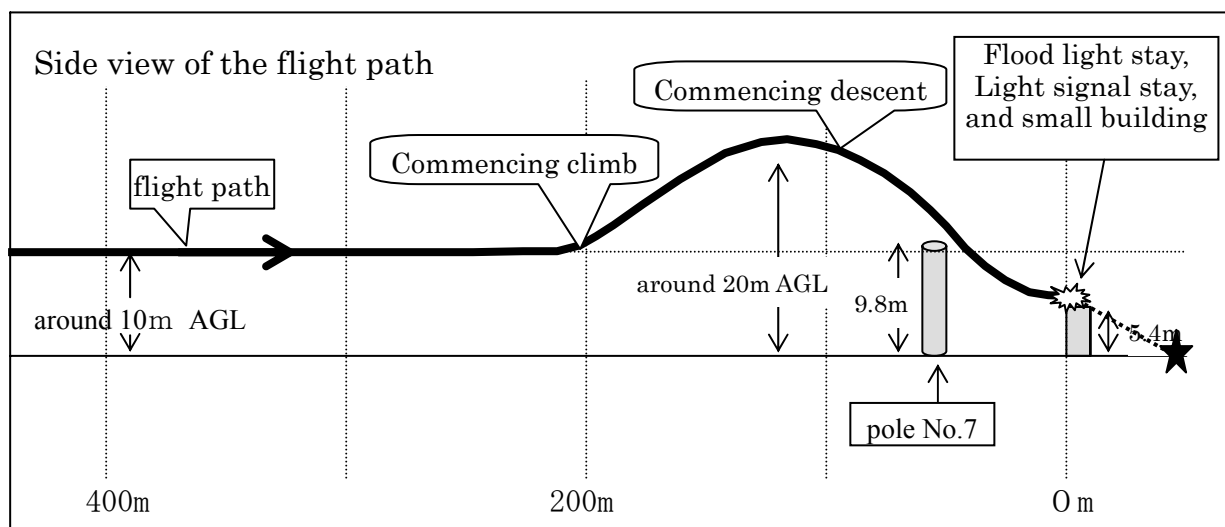

Figure3 Analysis of Estimated Flight Path



(Height and Width are emphasized by four times in above figure)

Figure4 Three angle view of Sukhoi Su-26

unit : m

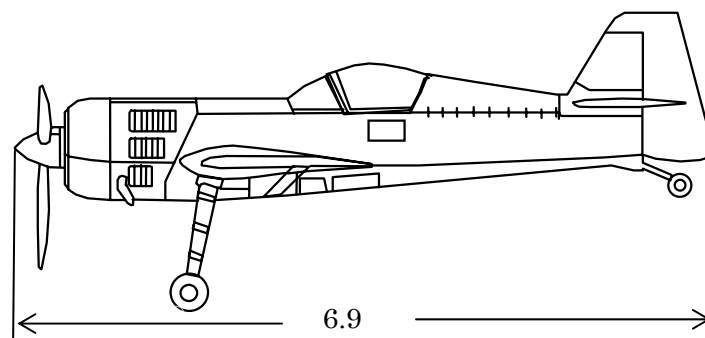
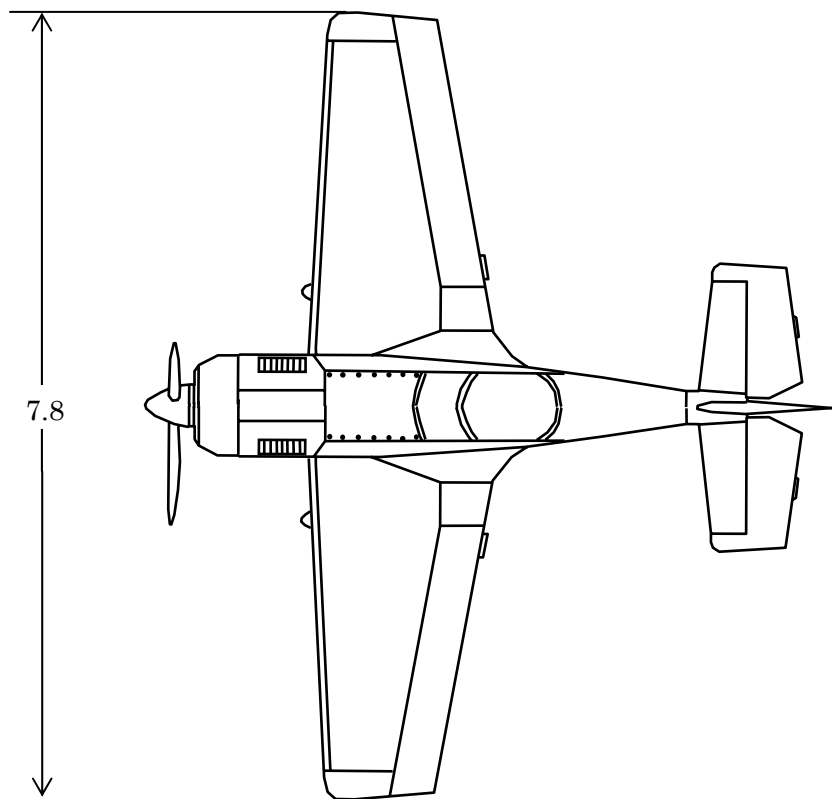
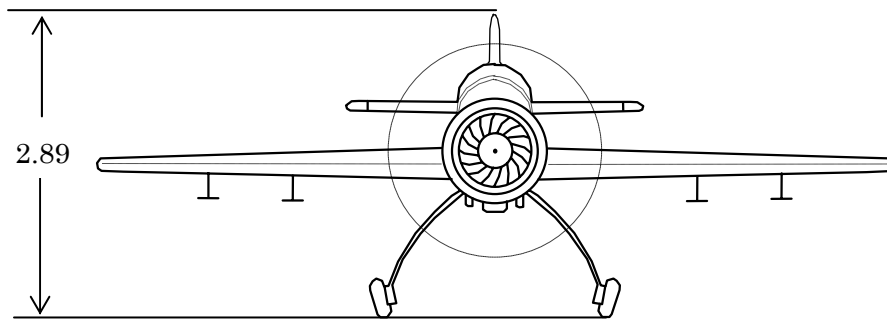

Attachment “Operating Standard” (Extract)

The following is an extract of the “Operating Standard” established by the sponsor and used for the Air Show.

Operating Standard (Extract)

1 General

- 1-1 Establishment of Operating Control Center
- 1-2 Keep strictly to instructions
- 1-3 Keep each other well informed
- 1-4 Carry out briefing: Put under obligation to attend to pilot briefing
- 1-5 Operating restriction: Weather limitations, operating limitations of each aircraft model

2 Pilot

- 2-2 Confirmation of physical condition of pilots: Confirmation of health condition, alcohol consumption, and influence by drugs at the morning briefing.

3 Aircraft

- 3-1 Confirmation of Aircraft Assembly

4 Event of Performance

5 Flight Airspace

- 5-1 Establishment of flight airspace

Area specified for aerobatic performance: The area should be over 185m horizontally from the spectator seats. Should carry out at an altitude able to fly as keep a distance over 30m from the facilities, etc in the field

Passing flight: Should be on course for automobile competition over 60m of horizontal distance from the audience.

6 Operating Managements

- 6-1 Ensure of communication devices and its operation

7 Flight Managements

- 7-2 Confirmation of flight path, etc: Should be informed thoroughly about performance area and passing flight area

- 7-3 Limitation in front of the seats for the audience: Should carry out only passing flight in front of the seats for the audience, the distance from the seat is to be over horizontally 60m. Should not carry out the performance with abrupt attitude change in front of the seat for the audience in passing flight

- 7-4 Flight path restrictions: Prohibited from passing over spectator seating.

Should not fly over nearby private house

- 7-5 Keep strictly to the flight path: Pilot should keep to the previously specified flight path.

8 Management on ground: Management of runway and apron area and management of airfield for emergency landing

9 Measures at urgent: Should correspond under “Urgent Correspondence” in the center for urgent countermeasures.