

AA2011-8

**AIRCRAFT ACCIDENT  
INVESTIGATION REPORT**

**NORTHWEST AIRLINES  
N 6 7 6 N W**

**December 16, 2011**

**Japan Transport Safety Board**

The objective of the investigation conducted by the Japan Transport Safety Board in accordance with the Act for Establishment of the Japan Transport Safety Board and with Annex 13 to the Convention on International Civil Aviation is to determine the causes of an accident and damage incidental to such an accident, thereby preventing future accidents and reducing damage. It is not the purpose of the investigation to apportion blame or liability.

Norihiro Goto  
Chairman,  
Japan Transport Safety Board

Note:

This report is a translation of the Japanese original investigation report. The text in Japanese shall prevail in the interpretation of the report.

# AIRCRAFT ACCIDENT INVESTIGATION REPORT

**NORTHWEST AIRLINES INCORPORATED  
BOEING 747-400, N676NW (THE UNITED STATES OF AMERICA)  
IN THE AIR ABOUT 174 KM SOUTH-SOUTHWEST OF NARITA  
INTERNATIONAL AIRPORT  
AROUND 11:45 JST, FEBRUARY 20, 2009**

December 2, 2011

Adopted by the Japan Transport Safety Board

Chairman	Norihiro Goto
Member	Shinsuke Endoh
Member	Toshiyuki Ishikawa
Member	Sadao Tamura
Member	Yuki Shuto
Member	Toshiaki Shinagawa

# **1. PROCESS AND PROGRESS OF THE INVESTIGATION**

## **1.1 Summary of the Accident**

On February 20 (Friday), 2009, a Boeing 747-400, registered N676NW, operated by Northwest Airlines Incorporated, took off from Manila (Ninoy Aquino) International Airport (the Philippines) bound for Narita International Airport (Japan) as the company's scheduled Flight 2. Around 11:45 Japan Standard Time (JST: UTC+9hr, unless otherwise stated, all times are indicated in JST on a 24-hour clock), the aircraft was hit by turbulence when it was flying at an altitude of about 30,300 ft about 174 km south-southwest of Narita International Airport (about 30 km north of Miyakejima Airport). Four passengers sustained serious injuries while 27 other passengers and seven flight attendants sustained minor injuries.

There were 422 people on board, consisting of the pilot in command (PIC), 13 other crewmembers and 408 passengers.

The aircraft interior was partially damaged.

## **1.2 Outline of the Accident Investigation**

### **1.2.1 Investigation Organization**

On February 20, 2009, the Japan Transport Safety Board (JTSA) designated an investigator-in-charge and two other investigators to investigate this accident.

This accident was initially believed to have occurred within Japanese airspace, but the data on the Digital Flight Data Recorder (DFDR) showed the accident had actually occurred over the High Seas. As a result, the United States of America, as the State of Registry of the aircraft involved, turned out to be responsible for investigating the accident in accordance with the provisions of Annex 13 to the Convention on the International Civil Aviation. However, with JTSA's initial launch of the investigation, the National Transportation Safety Board (NTSB) of the United States of America entrusted it to JTSA on March 6, 2009.

### **1.2.2 Representative from Foreign Authorities**

An accredited representative of the USA, as the state of Registry, the Operator, Design and Manufacture of the aircraft involved in this accident, participated in the investigation.

### **1.2.3 Implementation of the Investigation**

February 20 and 21, 2009                      Aircraft examination and interviews

February 25, 2009                              Interviews

### **1.2.4 Interim Report**

On May 28, 2010, an interim report based on the results of the fact-finding investigation up to that date was submitted to the Minister of Land, Infrastructure, Transport and Tourism, and made public.

### **1.2.5 Comments from Parties Relevant to the Cause of the Accident**

Comments were invited from parties relevant to the cause of the accident.

### **1.2.6 Comments from the Participating State**

Comments were invited from the participating State.

## 2. FACTUAL INFORMATION

### 2.1 History of the Flight

On February 20, 2009, a Boeing 747-400, registered N676NW (hereinafter referred to as “the Aircraft”), operated by Northwest Airlines Incorporated (hereinafter referred to as “the Company”), took off from Manila International Airport at 08:47 bound for Narita International Airport (hereinafter referred to as “Narita Airport”) as the Company’s scheduled Flight 2.

The outline of the flight plan was as follows:

Flight rule:	Instrument Flight Rule (IFR)
Departure aerodrome:	Manila International Airport
Estimated off-block time:	08:45
Cruising speed:	496 kt
Cruising altitude:	FL370*1
Route:	(Omitted) – Y533(airway) – TIC(Chinen VORTAC) – Y57 (airway) – MJE (Miyakejima VOR/DME) – A1 (airway) – ORGAN (reporting point) – Y231 (airway) – VENUS (reporting point)
Destination aerodrome:	Narita International Airport
Total estimated elapsed time:	3 hour and 25 minutes

There were 422 people on board, consisting of the PIC, 13 other crewmembers and 408 passengers. In the cockpit the PIC was in the left seat as the PM (pilot monitoring: pilot mainly in charge of duties other than flying) and the First Officer (hereinafter referred to as “FO”) was in the right seat as the PF (pilot flying: pilot mainly in charge of flying).

The cabin was staffed with a Lead Flight Attendant (LFA) and 11 Flight Attendants (FA).

The history of the flight is summarized below, based on the records of the DFDR, the Air Traffic Control (ATC) communication records and the radar track records as well as the statements from the two flight deck crews and the LFA.

#### 2.1.1 History of the Flight Based on Radar Track Records, ATC Communications and DFDR

11:30:18	The Tokyo Area Control Center (hereinafter referred to as “Tokyo Control”) instructed the Aircraft to descend to FL350 from FL370 when it was flying about 129 nautical miles (about 239 km) west-southwest of Miyakejima
----------	---

---

\*1 FL, which stands for flight level, is the pressure altitude in the standard atmosphere. The FL is expressed in the value given by dividing the reading on the altimeter (the unit is the foot) by 100 when the altimeter is set to 29.92 inHg. In Japan, flying altitudes of 14,000 ft or higher are usually indicated in the flight level. For example, FL370 means an altitude of 37,000 ft.

VOR/DME.

- 11:30:24 The Aircraft accepted it and requested Tokyo Control to change its heading to 040° from 055° in order to avoid cumulonimbi. Tokyo Control approved it.
- 11:32:00 The Aircraft further requested Tokyo Control to change its heading to 020° and Tokyo Control approved it.
- 11:34:07 Tokyo Control instructed the Aircraft to fly directly to ORGAN (reporting point), and the Aircraft accepted it.
- Around 11:37 The Aircraft requested Tokyo Control to change its heading then to avoid another cumulonimbus, but after an exchange of words with Tokyo Control, the Aircraft reported Tokyo Control that it would maintain previously directed heading of about 060°.
- 11:41:26 Tokyo Control instructed the Aircraft to descend and cross MAMAS (reporting point) at FL180. The Aircraft accepted it.
- 11:42:45 Tokyo Control instructed the Aircraft to change its heading to 080°.
- 11:42:48 The Aircraft accepted it and changed its heading to 080° while it was descending at an altitude of about 34,000 ft.
- 11:44:26 The Aircraft started to jolt.
- 11:44:30 to 44:52 The wind velocity began to change. The wind velocity dropped to about 100 kt from about 150 kt when the Aircraft was descending by about 500 ft from about 30,700 ft. (The tail wind component for the Aircraft also decreased to about 100 kt from about 150 kt and as a result, the rate of climb changed to an ascent of about 300 fpm from a descent of about 1,100 fpm.
- Around 11:44:43, the bumpiness became intensified with attitude fluctuations
- 11:44:53 to 44:55 When the Aircraft was descending at an altitude of about 30,300 ft, the vertical acceleration changed; from +1.36G to -0.52G, then to +1.70G. At that time, the pitch angle of the Aircraft decreased by about 0.5 degree in the nose-down direction and after the decrease, quickly increased by about two degrees in the nose-up direction.

In the rest of the flight until landing, the vertical acceleration changed intermittently while decreasing. The Aircraft landed at Narita Airport around 12:19 and parked at Gate 24 around 12:25.

During the period of fluctuated vertical acceleration after 11:44, the autopilot remained engaged.

## 2.1.2 Statements of Flight deck crews and LFA

### (1) PIC

The PIC contacted the Company's dispatcher from a hotel in Manila and discussed the flight to Narita. He received a detailed explanation from the dispatcher mainly about the possibility of a rainstorm around the time of arrival, the location of a strong jet stream, predictions of frontal passage and the likelihood of turbulence during descent and landing.

In a briefing conducted at the Aircraft, the PIC briefed the all of FAs about the possible turbulence and requested them to observe the seat belt signs and have all duties finished prior to descent.

Climb was smooth. In a cruise the PIC made passenger announcements (PAs) on expected bad weather at Narita Airport and the possibility of turbulence during descent and arrival, adding that seat belts be fastened whenever the seat belt sign is illuminated and for the safety's sake they should be fastened due to the unpredictable bumpiness. There were minor jolts in the cruise and at each occasion, the seat belt sign was turned on for about 15 minutes. About 10 to 15 minutes prior to the scheduled start of descent, the PIC made another PA on the weather and possible turbulence and turned on the seat belt sign. It was made in English followed by Tagalog and Japanese. The Aircraft was flying in an area of usual strong jet stream winds around 270° at more than 150 kt. There were several thin hazy clouds in the area. After the Aircraft descended to FL350 from FL370, he received an ATC instruction to turn to heading 080° after descending to FL180. Clouds were seen, but when the radar was directed downward to examine the clouds, there were no obvious cells showing. With this information the PIC concluded that there was no problem in the flight route ahead. The Aircraft descended into the clouds and encountered a moderate-plus (stronger than moderate\*<sup>2</sup>) turbulence at an altitude of about FL310. Later, the Aircraft exited the cloud.

When the PIC asked the LFA about the passengers' condition over the interphone, she first responded that everyone was fine, but in about two minutes, she told him that two persons appeared to be injured in the aft cabin section, asking his permission to go there for confirmation. Because the Aircraft was experiencing light\*<sup>2</sup> to moderate turbulence, he told her to return to her seat in four minutes. Her information had it that one child had the head hit against the ceiling and that another person was lying on the floor near Door 5R.

The PIC had the FO be in charge of flight control and communication

---

\*<sup>2</sup> Moderate/Light are terms used to express the degree of aircraft shaking. For specifics, see a Flight Attendant Manual (FAM), as described in 2.11.



with the ATC and reported to the Company's Narita Control Center that there were two injured persons and asked to have an ambulance and medical personnel stand by at the gate. When the Aircraft was in an approach, the PIC received a call from another FA in the aft cabin section that some people were injured there, but he interpreted this to be the two injured persons previously reported.

The PIC was busy with data input into the FMC\*<sup>3</sup> responding to the two active runway changes and the holding at VENUS (reporting point) which was given and canceled at some time into its holding. There were interphone calls from FAs twice or three times during the approach. If he responded their calls, he may have been able to obtain latest information about the conditions of the injured persons. But he was so preoccupied with performing landing procedures that he could not answer them. He prioritized going through the checklist for the safe landing. Because the Aircraft was top of the landing list, the PIC did not request priority for landing.

After parking the Aircraft, the PIC went down to the lower deck and found more than 20 injured persons there. When he talked to a few passengers, he learned that they had not fastened their seat belts.

(2) FO

According to the weather information, there were no particular problems with the departure and the cruise, but the weather forecasts during descent and approach to Narita were not good. He received a PIREP\*<sup>4</sup> to the effect that the Company's other flights had met turbulence. The Aircraft actually met turbulence when it started descent to FL180. The PIC handled all the cabin matters and coordinated with the Company's Narita Control Center. When the Aircraft landed and taxied to Gate 24, medical personnel were standing by there. The PIC and the FO came to know what actually happened in the cabin when they entered the cabin on the first floor.

(3)LFA

The LFA had received instructions from the PIC that FAs should be seated and fasten their seat belts by the time the Aircraft would start to descent – 25 to 30 minutes before arrival, because weather at Narita Airport would be very bad with strong winds.

When the Aircraft reached the cruising altitude, the seat belt sign was lit off. The PIC made a PA asking passengers to fasten their seat belts when they are seated for safety's sake even if the seat belt sign is off. During the cruise the seat belt sign lit on and off several times, but whenever the sign was illuminated, the PIC made PAs.

---

\*<sup>3</sup> The FMC is a processing system that manages the flights of aircraft from their takeoff to landing.

\*<sup>4</sup> PIREP means information mainly about the weather condition obtained from pilots during or after their flights.

When the Aircraft started descent, the seat belt sign was illuminated, and the PIC reminded the passengers to be seated and fasten their seat belts. At that time, the LFA was assisting FAs trying to confirm the safety of Galley 1, but she also advised FAs in the main cabin by interphone to be seated immediately after confirming the safety of their galleys.

The Aircraft experienced a big jolt 10 or 15 minutes after the start of the descent. The PIC called the LFA to confirm the cabin condition. She replied that there was no problem because the situation around her appeared normal, but she was not aware of the condition in the aft cabin section. Later, she received word from an FA in charge of Zone E in the aft cabin section that several passengers were injured. The LFA told the PIC that there seemed to be some injured persons in the aft cabin section and sought approval for going there to confirm the situation. The PIC urged her to return in four minutes because further turbulence encounter was expected and because landing was very soon. In the aft cabin section, one FA was bruised, while two physicians were holding the neck of a man lying on the aisle in Zone E. One small child was holding the head. The child apparently had a cut in the head by a panel which was detached when struck by another passenger.

The LFA reported to the PIC using the interphone near Door 5L about the neck condition and an urgent need to take care of three persons. The PIC announced to the passengers again asking them to fasten their seat belts. Because he was busy going through the landing procedures, the LFA was instructed to remind the passengers to be seated and fasten their seat belts. The LFA returned to her seat and made a PA that the passengers had to be seated and paramedics would come to take care of the injured persons when the Aircraft arrives at Narita Airport. The LFA advised two passengers, whom she previously asked to be seated in the jumpseats, to return to their own seats to avoid further injuries. A man who was in a galley and a woman who was lying between seats were also asked to do so.

When the Aircraft landed, an ambulance had already arrived there and paramedics entered the cabin through Door 2R. Inside the main cabin, the LFA helped passengers who do not need physicians' examination to disembark and confirmed six persons who had sought examination. Those who came from the Company's Narita branch office helped to deal with the passengers. The LFA took care of the injured passengers and helped them to be taken out of the Aircraft and she disembarked.

This accident occurred around 11:45, at an altitude of about 30,300 ft about 174 km south-southwest of Narita Airport (34°20'55" N, 139°33'32" E). (See Figure 1 Estimated Flight Route, Figure 2-1 DFDR Records (1), Figure 2-2 DFDR Records (2), Figure 3 Seat Locations of Injured Persons, Photo 1 The

Aircraft)

## 2.2 Injuries to Persons

Four passengers were seriously injured and a total of 34 persons (27 passengers and seven FAs) sustained minor injuries.

## 2.3 Damage to the Aircraft

After the Aircraft arrived at Narita Airport, the Company performed a mandatory post-turbulence inspection per maintenance manual. There was no damage to the Aircraft except for the following interior damage:

(1) Damage to the cabin ceilings above the following seats.

Scratches: Seat 21B, Seat 59J

Wrinkles, dents: Seat 41B, Seat 62H

Detached panels, dents: Seat 51K, Seat 55J

(2) Damage to the seats

Armrests: Seat 40D, Seat 57B, Seat 58G, Seat 66G

Tables: Seat 60F, Seat 64F

(3) Cracks and damage to the lavatory ceiling: In the aft left section.

(See Photo 2 Damaged Components)

## 2.4 Flight Crew Information

(1) PIC Male, Age 58

Airline Transport Pilot Certificate (Aircraft) April 30, 1979

Type rating for Boeing 747-400 November 10, 2003

Class 1 Aviation Medical Certificate

Validity May 5, 2009

Total flight time 13,702 h 48 min

Flight time in the last 30 days 21 h 12 min

Total flight time on the type of aircraft 3,146 h 43 min

Flight time in the last 30 days 21 h 12 min

(2) FO Male, Age 51

Airline Transport Pilot Certificate (Aircraft) May 26, 1989

Type rating for Boeing 747-400 April 13, 2008

Class 1 Aviation Medical Certificate

Validity March 9, 2009

Total flight time 11,631 h 00 min

Flight time in the last 30 days 95 h 24 min

Total flight time on the type of aircraft 1,477 h 08 min

Flight time in the last 30 days 95 h 24 min

## 2.5 Aircraft Information

## 2.5.1 Aircraft

Type	Boeing 747-451
Serial number	33002
Date of manufacture	April 18, 2002
Certificate of airworthiness	ODARF300064NM
Validity	Unlimited duration from April 18, 2008
Category of airworthiness	Airplane Transport T
Total flight time	31,810 h 41 min
Flight time since last periodical check (L maintenance on January 3, 2008)	2,476 h 33 min

(See Figure 4 Three Angle View of Boeing 747-400)

## 2.5.2 Weight and Balance

When the accident occurred, the Aircraft's weight was estimated to be 557,440 lb and the center of gravity was estimated to be 24% MAC\*<sup>5</sup>, both of which were estimated to be within the allowable ranges (the maximum takeoff weight of 870,000 lb, and 13% to 33% MAC corresponding to the weight at the time of the accident).

## 2.6 Meteorological Information

### 2.6.1 General Weather Information

#### (1) Surface Analysis Chart

According to the Asia-Pacific surface analysis chart as of 09:00 on the day of the accident, there were two developing low pressures near the Tokai region and in the middle of the Sea of Japan, and both of them were moving eastward.

A cold front extended from the low pressure near Tokai region toward Nansei Islands via the ocean east of Shikoku and Kyushu. A warm front extended from the same low pressure toward the ocean east of Kanto region.

#### (2) Upper Analysis Chart

According to the upper analysis chart (AXFE578) as of 09:00 on the day of the accident, isothermal lines on the lower layer (850 hPa and 700 hPa) were bulging to the north in the regions of Tokai, Kanto and Tohoku, creating an upward flow area. From the ocean off Tokaido region to the ocean east of Kanto region, winds were blowing from the south at about 50 kt in a direction that intersects the isothermal lines at right angle, indicating a conspicuous amount of warm air was blowing into the areas.

According to the upper analysis chart (AUPQ35), two strong jets were seen in the upper layer (300 hPa), the northern one extending from North

---

\*<sup>5</sup> MAC stands for the mean aerodynamic chord. This term means the wing chord that represents the aerodynamic performances of wings and indicates their average for cases in which the wing chord is in an irregular condition, such as the swept-back wing. The figure in question, 24%MAC, shows a position 24% from the leading edge of the mean aerodynamic chord.

China region to Hokkaido via Korean Peninsula and the southern one from Central China to the ocean east the Japanese Archipelago via the East China Sea and western Japan. Along the strong jet running south of the Japanese Archipelago, winds were blowing from the west at a velocity of about 130 kt near Japan.

(See Figure 5 Asia-Pacific Surface Analysis Chart, Figure 6-1 Upper Analysis Chart (AXFE578), Figure 6-2 Upper Analysis Chart (AUPQ35))

### **2.6.2 Meteorological Satellite Image, Relevant Satellite Cloud Information Chart and Weather Radar**

- (1) According to the meteorological satellite image (visible) as of 11:36 on the day of the accident, clumpy convective clouds stretched from the waters off Tokaido region to the ocean east of Kanto region.
- (2) According to the relevant satellite cloud information chart as of 12:00 on the day of the accident, clouds with a top height of 20,000 to 30,000 ft stretched from the waters off Tokaido region to the waters east of Kanto region.
- (3) According to the weather radar image as of 11:40 and 11:50 on the day of the accident, a precipitation area was observed at a place that corresponds to the convective cloud area described in (1) above. A strong rain area with a precipitation of 32 millimeters per hour or more was observed near the place where the accident occurred. The echo top height\*<sup>6</sup> was eight to 10 km (about 26,200 to 32,800 ft).

(See Figure 7 Meteorological Satellite Imagery (Visible), Figure 8 Weather Radar Imagery, Figure 9 Relevant Satellite Cloud Information Chart)

### **2.6.3 Hourly Analysis Chart**

According to the vertical section at Longitude 140° E on the hourly analysis chart as of 12:00 on the day of the accident, jet streams was observed near Latitude 40° N at an altitude of about 37,000 ft and near Latitude 35° N at an altitude of about 35,000 ft. A strong wind area near the jet stream at an altitude of about 35,000 ft extended downward. A wind velocity near Latitude 35° N at an altitude of 26,000 to 30,000 ft was 130 to 140 kt, and the vertical wind shear\*<sup>7</sup> was estimated at 6 kt per 1,000 ft.

(See Figure 10 Hourly Analysis Chart)

### **2.6.4 Aviation Weather Observed at Narita Aviation Weather Service**

---

\*<sup>6</sup> The echo top height means an altitude where drops of rain (flakes of snow) are observed with the weather radar.

\*<sup>7</sup> Vertical wind shear is the difference in wind direction and velocity at locations obtained through wind analysis, between the top and bottom layers converted into the difference per 1,000 ft. It becomes larger as the change in wind direction or velocity, or both in accordance with altitude change.

## Center

- 11:14 Wind Direction 160°, Wind velocity 6 kt, Visibility 3,600 m,  
Present weather Light shower rain, Mist  
Cloud Amount 1/8, Cloud type Stratus, Cloud base 100 ft  
Amount 3/8, Cloud type Stratus, Cloud base 300 ft  
Amount 7/8, Cloud type Stratocumulus, Cloud base 5,000 ft  
Temperature 5 °C, Dew point 4 °C  
Altimeter setting (QNH) 29.41 inHg  
Remark P/FR (Pressure Falling Rapidly)  
(A drop in the atmospheric pressure in excess of 0.03 inHg during  
30 minutes before observation)
- 11:47 Wind Direction 250°, Wind velocity 6 kt, Wind direction change 210° to  
300°,  
Visibility 3,200 m, Present weather Light shower rain, Mist  
Cloud Amount 1/8, Cloud type Stratus, Cloud base 100 ft  
Amount 7/8, Cloud type Stratus, Cloud base 200 ft  
Temperature 6 °C, Dew point 5 °C  
Altimeter setting (QNH) 29.38 inHg

### 2.6.5 Information Obtained by the Aircraft

The Company's Narita Control Center provided the following information to the Aircraft through the Aircraft Communication Addressing and Reporting System (ACARS) which links between each aircraft and the operating company's host computer:

The message sent at 11:46

Change of active runway at Narita Airport 16R/16L

PIREP from the Company's flight 905

11:30

Light to moderate turbulence observed at an altitude of FL200 to 6,000 ft,  
light turbulence from an altitude of 6,000 ft to landing.

### 2.7 Information on DFDR and Cockpit Voice Recorder

The Aircraft was equipped with a DFDR (part number: 980-4700-042) and a cockpit voice recorder (hereinafter referred to as "CVR") (part number: 980-6022-001), both made by Honeywell in the United States of America.

The DFDR retained the data from the time when the Aircraft took off from Manila International Airport to the time when the Aircraft landed at Narita Airport. The time was adjusted by synchronizing the DFDR's VHF transmission keying signals to the NTT time signal recorded on the ATC communication records.

The CVR was capable of recording about 120 minutes of voices, however, the voices at the time of the accident was erased by overwriting.

## 2.8 Medical Information

The places and the degrees of injuries of the seriously injured passengers are as follows:

- (1) Injured Person A      Multiple fracture of the costae  
(Passenger in Seat 58B, Male, Age 65)
- (2) Injured Person B      Avulsion fracture of the No. 2 cervical vertebra body,  
Fracture of the left arch bone of the No.7 cervical  
vertebrae  
(Injured in the lavatory in the left aft section)  
(Passenger in Seat 67E, Female, Age 35)
- (3) Injured Person C      Compressed fracture of the No. 5 thoracic vertebrae,  
Central damage to the cervical cord  
(Passenger in Seat 61J, Female, Age 60)
- (4) Injured Person D      Fracture of the No. 2 cervical vertebra body,  
Fracture of the spine of the No. 6 cervical vertebrae,  
Bruises in the head  
(Passenger in Seat 64G, Male, Age 65)

## 2.9 Cabin Condition

The cabin condition of the Aircraft was summarized as below according to the seat allocation, and the statements of FAs and injured persons.

### 2.9.1 Summarized Statements of 11 FAs

- (1) Three FAs in the Forward Cabin section (Zones A and B)

The PIC advised in a briefing in Manila that FAs should also be seated by the time 40 minutes before arrival because the Aircraft would encounter turbulent air due to strong winds about 20 minutes before landing. During the flight, PAs urging the passengers to fasten their seat belts were made seven times or so in English, Tagalog and Japanese.

Because the FAs remembered the PIC's briefing that there would be foul weather, they took their seats earlier than usual after confirming the safety of the galleys and finishing other duties. It was 11:45 to 11:50 when aircraft encountered light bumpiness followed by strong one 20 to 30 seconds later. The seat belt sign had been illuminated at that time. FAs who happened to be in the aisles were keeping themselves by holding on to the rack, and then crawling to the jumpseats. There were no injured persons in the forward cabin section, nor was there anybody screaming. After the strong bumpiness, FAs told the passengers in a PA to remain in their seats. They also paged for physicians.

FAs were reporting to the LFA by interphone that passengers have sustained injuries in the aft cabin section. The FAs in the forward cabin section presumed that several persons had been injured in the aft cabin section, but when the FAs went there after their passengers disembarked, they found many

injured passengers in the aft section. It was about two hours after the arrival when all injured passengers and FAs were hospitalized.

(2) Two FAs in the Upper Deck (UD)

FAs were briefed by the PIC before departure from Manila that the Aircraft would encounter turbulence about 20 minutes before arrival. The PIC advised FAs to be seated by that time after clearing up and confirming the safety of the galleys. The PIC made a PA after the takeoff that they should fasten their seat belts, whenever seated.

When the seat belt sign was illuminated, FAs confirmed whether the passengers fastened their seat belts and took their own seats with the seat belts fastened. The PIC also made a PA that they should fasten their seat belts. When the Aircraft dropped violently, nobody was standing in the upper deck, and all were safe.

(3) Three FAs in the Mid Cabin section (Zones C and D)

The PIC told in a pre-flight briefing that the Aircraft would encounter turbulence 20 minutes before arrival at Narita Airport.

About 30 to 35 minutes before the estimated time of arrival, the PIC made a PA that they should fasten their seat belts because bumpy flight was expected during the descent. The PIC made this message in English. The message was repeated later in Japanese and Tagalog. At that time, FAs were working in the galleys or in the aisles. Some passengers were using the lavatories and some others were chatting with their friends, which were common cabin situation.

The flight became bumpy soon after the seat belt sign was illuminated. The FAs hurriedly tried to take the nearest jumpseats, but because the Aircraft dropped suddenly before the FAs take their seats, one of them had the head bumped against the ceiling. The flight became very bumpy and passengers were screaming. The FAs kept themselves by holding to the seat posts or the carts. In Zone E, some unseated passengers fell on the floor after bumping their heads against the ceiling, and one of them was unable to move. Two doctors, a father and his son who happened to be aboard, joined to treat the injured.

The LFA made a PA on behalf of the pilot because they were busy communicating with ATC before landing. The LFA urged the passengers to take their seats. She announced that FAs should also be seated but that if they could move safely, they would take care of the injured persons. The PA was initially made in English and then repeated in Japanese and Tagalog.

The PIC also announced that FAs should also be seated.

When FAs checked the areas where persons were injured after the arrival at Narita, they found a greater number of injured persons than expected. The FA call buttons were pressed one after another by injured persons and persons who need assistance. Because the number of paramedics



was insufficient, the two doctors also gave temporary treatment to the injured persons. FAs had difficulty communicating with the paramedics to explain the situation due to language barriers.

- (4) Three FAs in the Aft Cabin section (Zone E) and the FA who came for Assistance from the Middle Section to the Aft Section when the Injuries Occurred

The FAs had been told by the PIC in a briefing that the Aircraft would experience bumpy flight about 20 minutes before arrival.

The PIC made a PA that the Aircraft would start descent and the seat belt sign was illuminated. The FAs tried to take their jumpseats in a hurry, but because the aircraft encountered a big bumpiness just after the sign was illuminated, they could not be seated. Some people, including FAs, were thrown upward to the ceiling, and many passengers were injured. FAs took care of the injured by preparing a make-shift neck collar with a folded airline magazine for holding an injured person's neck and assisting passengers who were not able to move.

After the bumpiness was reduced, the FAs fetched first aid equipment and paged for any available doctor on board. A little later, two physicians, who were a father and his son, showed up and began to take care of the injured persons. The FAs told the LFA that the situation in the aft cabin section was worse than in the forward and that neck collars and stretchers were necessary for the injured.

The LFA came to the aisle in the aft cabin section and reported to the cockpit about the situation. After the LFA returned to the seat, the FAs told the PIC that the physicians and those FAs who were taking care of the injured passengers would not be seated due to their attendance to the injured and that an ambulance as well as neck collars and stretchers should be prepared on the ground. The PIC replied that such requests had already been made.

While the Aircraft was taxiing after the landing, the call buttons in Zone E lit up. An FA made a PA that everybody should remain seated for rescuers' easy access to the injured passengers and then, went to Door 5 and asked if there were any other injured persons. Many passengers raised their hands. They were groaning in pain and seeking help. FAs busily treated passengers who suffered bruises or cuts with first aid equipment; some FAs took care of passengers who became emotionally stressed after the bumpiness.

The FAs made PAs not to move for unnecessary reasons, and not to drink anything because they would be served with cube ices to moisten their mouth. The FAs also told the passengers not to sleep and to stay conscious even if they feel sleepy.

One passenger in the aft cabin section had her head hit against the ceiling in the lavatory. One FA sustained injuries in the shoulders, while six passengers complained of pains in the neck. Three passengers were bleeding in

the head and four passengers complained of pains in the chest. Near Door 4R, an infant had the head strongly hit. His mother was vomiting; his father sustained injuries.

Flight management staff, paramedics and ground staff at Narita Airport came in to assist them, and the passengers and FAs who sustained injuries or being sick were taken by ambulances to several hospitals.

## **2.9.2 Statements of Four Injured Persons**

### **(1) Injured Person A (Seat 58B)**

The Aircraft was flying smoothly until halfway, but we encountered a sudden strong bumpiness, and I was surprised very much. I had two costae fractured at that time. Around me, there were some people crying or screaming. Maybe because I lost consciousness, I cannot remember what happened after that. Because I was aware that the Aircraft had entered a landing phase, I returned my seat back to upright position. I could not remember if the seat belt sign had been illuminated. I kept my seat belt fastened always except when I went to the lavatory. But the bumpiness was so strong that a fastened seat belt may be of little help to hold the body properly. Because it was a strong lateral jolt, I think I had my torso hit against the armrest.

### **(2) The Husband (Seat 61H) of Injured Person C (Seat 61J)**

The Aircraft took off from Manila on time. Weather was fine. The Aircraft occasionally entered small air pockets, but it was flying smoothly as a whole. I think it was about 30 minutes before arrival when the Aircraft entered a very big air pocket. My wife had her head hit against the ceiling and fell on the floor in front of her seat. Some people were lying on the floor. When the Aircraft arrived at the airport, an ambulance was standing by. Doctors who happened to be aboard the Aircraft were treating the injured persons. It took a long time before my wife was taken to an ambulance.

I do not remember whether the seat belt sign was illuminated. Before departure, we were instructed to fasten seat belts. While in flight, there heard PAs to fasten seat belts from time to time. As I saw some seat stickers advising to fasten seat belts, I had my seat belt fastened tightly. Because my wife was eating something after returning to her seat, I am afraid her seat belt was not tightly fastened.

### **(3) Injured Person D (Seat 64G)**

I was dozing off in my seat. When I heard a PA that turbulence would be expected from then on, the Aircraft was already shaking. Because I saw the seat belt sign flashing, I fastened my seat belt. But when I felt a little bit cold, I loosened my seat belt and raised myself to adjust the overhead air conditioning outlet and I sat back in my seat. When I tried to fasten my seat belt, I recall I had my head hit against something. When I regained consciousness, I found

myself lying on the floor. With my legs extended straight, I felt tingling sensation all over my body. A man came up to me and asked if I was all right. I was told to keep my body as it is. I immediately realized that I had my neck bone fractured. Because I am a nurse, I realized I should not move and kept my body still. The man was an orthopedic doctor. He placed a temporary neck collar around my neck and told me to wait. A paramedic came to me 10 or 20 minutes after arriving at Narita Airport.

(4) Passenger E (Slight injury) (Seat 58A)

The Aircraft was initially flying smoothly. When I was thinking that there were a lot of clouds in the sky, the Aircraft suddenly sank in a dive-like angle. Probably, I had my head hit against the ceiling. I do not remember whether the seat belt sign was illuminated. I think that there was no announcement until the accident occurred. After the big bumpiness, an FA paged for any available doctor to treat the injured persons. Actually one doctor was aboard and he was giving temporary treatments to the injured persons. I think I fastened my seat belt, but I don't remember if I did it tightly or not. I was tossed up and down, just like a bouncing ball. Because I had my body apparently hit hard against something. I had pains in the neck, so I remained seated. Some people were shouting while others were lying on the floor. A PA had it that all people should remain seated because turbulence was expected. Although I remained seated, I felt something unusual in the neck. Because I felt pains in the head, I was waiting for help. A doctor came to me and palpated my neck. He told me not to move. I was given an ice bag and moved to a wheelchair. I was taken to a hospital after a lapse of long time.

### **2.9.3 Seat Arrangement and Its Occupancy**

The Aircraft has 65 seats in the World Business Class (on the upper deck and in the first floor Zone A and B) and 338 seats in the Coach Class (in the first floor Zone C, D and E). The actual number of passengers on the day of the accident was 408 (64 in the World Business Class and 338 in the Coach Class in addition to six passengers who have no influence on the number of seats – infants).

Meanwhile, there were 11 FAs aboard the Aircraft, five for the World Business Class and six for the Coach Class.

(See Figure 3 – Seat Locations of Injured Persons)

### **2.10 Information on Rescue Activities**

Information on rescue activities was summarized as below according to the history of the rescue activities in addition to the statements of employee at the Company's Narita Control Center and paramedics.

### **2.10.1 The Statements of an Employee at the Company's Narita Control Center**

The Aircraft flight management is done by persons in charge at its head office. The Company's Narita Control Center assisted its flight as necessary while maintaining contact with the head office.

Around 12:00 on the day of the accident, a radio message came in from the Aircraft, saying that medical treatment became necessary for two passengers who were injured when the Aircraft encountered turbulence during its descent. The word had it that one of the injured persons, who was an infant, had the head hit against the ceiling, while the other person was lying on the floor. While the Control Center tried to get two wheelchairs, they received another message around 12:10 that a neck collar and a stretcher were necessary for the person lying on the floor. The condition of the infant was said to be stable. The Control Center judged that an ambulance was necessary for the injured person and asked for one.

After the Aircraft arrived at Narita Airport, the employees of the Company went to the aft section of the cabin. They found many passengers in need of medical treatment. They also saw paramedics working on triage\*<sup>8</sup>. The number of injured passengers who needed ambulance transport increased.

The Control Center collected information on the cabin situation from the employees who entered the cabin using transceivers and mobile phones. Because the number of ambulances mobilized was not enough, some of the passengers who became sick or sustained injuries were transferred to a bus-like vehicle which was brought there by paramedics. The vehicle left for a hospital around 15:10.

### **2.10.2 The Paramedics' Statements**

Word which reached paramedics had it that one person had the head hit against something and had pains in the neck. As a result, one ambulance was mobilized. After the Aircraft arrived at the boarding gate, a lifter car started moving to fix itself to the right side door second from the front. When paramedics entered the Aircraft through the door, they found a sizable number of passengers moving out through the door on the opposite side over to the No. 24 boarding bridge. When they went to the aft section of the cabin, they saw one person supinely lying on the aisle with his legs to the nose of the aircraft. They also found a woman lying on the floor with her head directed to the aisle two or three seats in front of the man in the right-side seat rows. Some people remained seated in areas from Door 2R to the back of the cabin and nobody was moving.

Paramedics came to know through an interpreter that they sustained injuries because the Aircraft encountered turbulence. When they looked around to confirm if there were any other injured persons, they saw six or seven injured people, or about 10

---

\*<sup>8</sup> Triage is the sorting process that determines the order of treating patients according to their degrees of injuries.

people with attending people combined turning their faces to the paramedics from their seats. The paramedics did not have a firm belief, but judging from the injured people's facial look, they concluded that more ambulances must be called and asked for additional paramedics and finding medical facilities ready to accept the injured. Paramedics asked FAs to announce to the passengers urging that those who can walk should move by themselves and those who cannot do so should remain as they were and wait for help. Then, two paramedics started triage. In general it appeared that there were more persons with serious injuries in the aft cabin section.

### 2.10.3 History of Rescue Activities

The history of rescue activities was summarized as below according to the Narita Fire Department's rescue activities records.

12:11	One ambulance was requested.
12:19	It arrived at the boarding gate.
12:41	A request for more help was received.
13:00 to 13:05	Four ambulances arrived at the gate.
13:28	Additional request for help was received.
13:49 to 13:51	Two ambulances arrived at the gate.
13:58	Yet additional request for help was received.
14:31 to 14:50	Eight ambulances arrived at the gate.
15:54	The 15 ambulances transferred a total of 43 injured persons, initially those with serious injuries, to six hospitals, shuttling a total of 17 times between the airport and the hospitals.

### 2.11 Additional Information

The following remarks are included in the Company's FAM (Flight Attendant Manual):

#### *Turbulence Guidelines*

(Omitted)

<b><i>Remember the following when dealing with turbulence:</i></b>
<i>• Discuss turbulence procedures and use designated levels of turbulence when communicating turbulence information during briefings and in flight.</i>
<i>• Turbulence levels are not the same throughout cabin. Intensity levels in forward sections may be less than those in aft sections.</i>
<i>• Cabin crew members should be seated immediately when directed by the captain to take their seats due to moderate or severe turbulence. They should remain seated until further communication with the captain.</i>

(Omitted)

**Communication During Turbulent Flight**

<b>Responsibility</b>	<b>Communication</b>
<i>Flight deck crew</i>	(Omitted) <i>NOTE: If moderate turbulence is anticipated, flight deck crew should ensure FAs are allotted adequate time to stow service equipment before entering areas of turbulence.</i> • <i>Turn on seat belt sign.</i>
<i>Purser/LFA</i>	(Omitted) • <i>Conduct “all-call” to ensure passengers and cabin crew are seated when level of turbulence calls for it.</i> (Omitted) • <i>Notify flight deck of any passenger and/or cabin crew injuries.</i>
<i>FAs</i>	(Omitted) • <i>Advise Purser/LFA if any passenger or crew member is injured by turbulence.</i>

**Turbulence Action Chart**

<b>Levels of Turbulence/Conditions</b>	<b>Flight Deck Response</b>	<b>Cabin Response</b>
<b>Light</b> • <i>Beverage shake inside cups.</i> • <i>Carts still maneuverable.</i>	(Omitted)	(Omitted)
<b>Moderate</b> • <i>Beverage splash from cups.</i> • <i>Carts are difficult to maneuver.</i>	• <i>Ensure seat belt sign is ON.</i> (Omitted) • <i>Make announcement reinforcing need for FAs and passengers to be seated and service to be discontinued.</i>	<i>Do not wait for guidance from flight deck crew if experiencing moderate turbulence.</i> • <i>Discontinue service and stow all carts.</i> (Omitted) • <i>FAs secure themselves in jumpseats as soon as possible using seat belt and shoulder harness.</i>
<b>Severe</b> • <i>Items fall over or lift from surfaces.</i> • <i>Standing is impossible without holding on to</i>	<i>NOTE: Flight deck crew should not fly into anticipated (known) severe turbulence.</i>	<i>Do not wait for guidance from flight deck crew if experiencing severe turbulence.</i>

<p><i>a part of aircraft.</i></p>	<p><i>Ensure seat belt sign is ON.</i></p> <p><b><i>When Operationally Safe To Do So:</i></b></p> <ul style="list-style-type: none"> <li><i>• Make announcement reinforcing need for FAs and passengers to be seated and service to be discontinued.</i></li> </ul>	<ul style="list-style-type: none"> <li><i>• Discontinue service immediately and leave carts with brakes engaged until turbulence is reduced.</i></li> <li><i>• FAs secure themselves in nearest available seats. If in jumpseat, use seat belt and shoulder harness.</i></li> </ul>
-----------------------------------	---	---

The following remarks are included in the Company's FOM (Flight Operations Manual):

**9.35.1 FLIGHT OPERATIONS**

(Omitted)

**Cockpit Voice Recorder Deactivation**

*The cockpit voice recorder must be deactivated if your flight was involved in:*

- an accident, or*
- an incident in which the recording would be relevant to an NTSB investigation.*

**15.35.1 EMERGENCY**

**Aircraft Accident**

**Definitions**

**Aircraft Accident** (Ref.: NTSB 830.2) *is an occurrence associated with the operation of an aircraft which takes place between the time any person boards the aircraft with the intention of flight and all such persons have disembarked, and in which any person suffers **fatal injury** or **serious injury**, or in which the aircraft receives **substantial damage**.*

- **Fatal Injury:** Any injury which results in death within 30 days of the accident.*
- **Serious injury:** Any injury which requires hospitalization for more than 48 hours, commencing within 7 days from the date the injury was received; results in a fracture of any bone (except simple fractures of fingers, toes, or nose); causes severe hemorrhages, nerve, muscle, or tendon damage; involves any internal organ; or involves second or third-degree burns, or any burns affecting more than 5 percent of the body surface.*

(Omitted)

**Aircraft Accident Guidelines**

*In the event of an aircraft accident, the following procedures should be followed by the flight crew to the extent possible:*

(Omitted)

- Deactivate the cockpit voice recorder (see also 9.35).*

### **3. ANALYSIS**

#### **3.1 Flight Crew Qualifications**

The PIC and the FO held both valid airman competence certificates and valid aviation medical certificates.

#### **3.2 Airworthiness Certificate**

The Aircraft had a valid airworthiness certificate and had been maintained and inspected as prescribed.

#### **3.3 Meteorological Phenomena**

As described in 2.6.1, because warm and damp winds were blowing from the south into the low pressure near the Tokai region, generating unstable atmospheric condition. As a result, as described in 2.6.2, it is considered highly probable that clumpy convective clouds were developing there. As described in 2.6.3, a vertical wind shear of 6 kt per 1,000 ft was observed amid jet stream near Latitude 35° N at an altitude of 26,000 to 30,000 ft. Therefore, it is considered highly probable that turbulent air was generated in the airspace near the place where the accident occurred.

#### **3.4 Flight of the Aircraft**

As described in 2.1.1, the Aircraft requested permission to change its heading when it descended from the cruising altitude of FL370 to FL350. It is considered highly probable that this was aimed to avoid cumulonimbi. The Aircraft was instructed by Tokyo Control to descend to FL180 and change its heading to 080°. According to the statement described in 2.1.2 (1), because clouds were observed in that direction, the Aircraft examined the clouds ahead with its radar, but there was no clear cumulonimbus on the radar screen. Therefore, it is considered highly probable that the Aircraft made a descent through the clouds keeping the direction as instructed.

According to the DFDR record concerning the vertical acceleration which indicates vertical bumpiness of flight, it is considered highly probable that the Aircraft encountered turbulence around 11:44:26 and the bumpiness began bigger from around 11:44:43 with the Aircraft's attitude change and then, reaching its culmination at 11:44:53 to 11:44:55 at an altitude of about 30,300 ft. It is considered highly probable that this bumpiness resulted from the influence of the turbulence as described in 3.3.

As described in 2.6.3, the wind velocity was 130 to 140 kt in the vicinity of the airspace where the accident occurred. But as described in 2.1.1, the wind velocity that the Aircraft actually flew varied by about 50 kt from about 150 kt to about 100 kt. Therefore, it is considered highly probable that the Aircraft was influenced by the sudden large wind velocity change near the airspace where the accident occurred.

#### **3.5 Comparison of Situation in Forward and Aft Cabin Sections**

According to the statements described in 2.1.2, 2.9.1 and 2.9.2, it is considered



probable that the PIC made a PA urging passengers to fasten their seat belts before the Aircraft starts descent with a caution that turbulence was anticipated during the descent and turned on seat belt sign. It is considered highly probable that the seat belt sign was turned on before the Aircraft encountered turbulence.

According to 2.9.3, the seats on the Aircraft were almost fully occupied. As drawn in Figure 3, passenger density was higher in the middle and aft cabin sections compared to the forward and upper deck sections. The number of passengers per one FA was about 13 persons for the World Business Class in the forward and upper deck sections, while the number was far higher at about 56 for the Coach Class seats in the middle and aft cabin sections. It is considered probable that although the contents of services differed from class to class, it took longer to finalize post-service duties and confirm the safety of passengers in the middle and aft cabin sections.

Regarding the time between the seat belt sign lighting up and the onset of bumpiness as described in 2.1.2 (3) and 2.9.1, the statements such as “10 to 15 minutes after the lighting up” or “bumpiness occurred after the safety confirmation after lighting up” suggest there were enough preparation time in the forward and upper deck sections. Meanwhile, in the middle and aft cabin sections the statements such as “the bumpiness started shortly after” or “just after lighting up of the seat belt sign,” suggest there was not enough time. It is considered probable that this difference resulted from the differences in the amounts and contents of duties FAs have to perform when the seat belt sign lights up and the differences of individuals’ feelings concerning the degree of bumpiness. But it was not available to determine how much time existed between the seat belt sign lighting on and the onset of the bumpiness.

However, in the middle and aft cabin sections where one FA has to take care of more passengers and more time is necessary for post-service clean-up and safety confirmation, it is considered probable that big bumpiness started before safety was fully confirmed after the lighting up of the seat belt sign. Therefore, it is considered probable that when big bumpiness occurred, the passengers in the forward and upper deck sections had been seated with their seat belts fastened, while some passengers in the middle and aft cabin sections had left their seats or had not fastened their seat belts, or their seat belts had not been fastened properly.

According to the history of the flight as described in 2.1.1 and Figure 2-2, the Aircraft encountered big bumpiness around 11:44:54, and a vertical acceleration of -0.52G was registered concurrently the pitch angle decreased followed by quick increase. It is considered probable that the aft section of the Aircraft sank suddenly corresponding to this pitch change and as a result it was subjected to a large negative vertical acceleration than in the forward.

It is considered somewhat likely that these factors led to more injuries in the middle and aft cabin sections.

As indicated in the FAM (Flight Attendant Manual) described in 2.11, aircraft bumpiness may be greater in the aft cabin section than in the forward cabin section.

FAs in the aft cabin section are required to keep this in mind when they prepare in-flight service plans and confirm the safety of passengers.

### **3.6 Awareness of Turbulence Encounter**

Before the Aircraft's departure from Manila International Airport, the PIC had obtained a weather forecast that weather would be worse at Narita Airport as well as information that aircraft would encounter turbulence during the descent. Because the PIC requested FAs in a cabin briefing to be seated during a descent due to anticipated foul weather and bumpy flight, it is considered highly probable that the FAs had been aware that the Aircraft would encounter turbulence.

According to the statements of FAs as described in 2.1.2 (3) and 2.9.1, it is considered probable that the PIC had made a precaution to the effect that bumpy flight would be expected and that the FAs should also be seated 25 to 30 minutes before, or 40 minutes before arrival to be prepared for rough air anticipated 20 minutes before arrival. But as described in 3.5, because the amounts and contents of their duties varied from section to section and also because the awareness about the PIC's caution differed from person to person, it is considered somewhat likely that among the FAs there was a difference in starting the counter-turbulence preparation such as post-service clean-up and confirming passengers' safety. The encounter of turbulence is foreseen to some extent by using weather analyses and its forecast except the specific timing of encounter. Crewmembers need to strive to have a common, proper picture of the anticipated phenomena and share related information in order to establish cabin safety readiness.

As described in 3.5, it was not determined how much time existed between the lighting up of the seat belt sign and the onset of bumpiness. But with the PIC's pre-flight briefing all crewmembers had knowledge of anticipated turbulence during the descent. Therefore, like the FAs in the forward and upper deck sections did, it is considered probable that the FAs in other sections of cabin were able to confirm passengers' safety before the Aircraft encountered the turbulence.

### **3.7 Recognition of and Response to Injured Persons**

According to the statements described in 2.1.2, 2.9.1, 2.9.2, 2.10.1 and 2.10.2, it is considered probable that injured persons were recognized as described below in the circumstances after the conspicuous aircraft jolt.

- (1) Passengers were directed to be seated as the seat belt sign was illuminated and the bumpiness continued. The LFA received reports from FAs in the aft cabin section that some persons sustained injuries. The LFA, with the PIC's permission to leave the seat, confirmed the situation there in a limited time and informed the PIC of the conditions of two passengers and one FA, mainly about the condition of an injured person lying on the floor. The PIC asked for mobilizing one ambulance because the bumpy flight continued and all occupants including the injured were required to be seated. Therefore it is

considered highly probable that the situation of the cabin could not be precisely confirmed and this made it difficult for the PIC to think that medical assistance would be necessary for injured persons other than the passenger lying on the aisle.

As described in 2.1.1, the Aircraft was descending in an approach for landing, but the active runway was changed repeatedly following changes in the weather condition at Narita Airport amid the influence of the approaching low pressure. It is considered highly probable that the cockpit crew were unable to answer the interphone calls from the FAs and accurately grasp the situation in the passenger cabin because they were occupied by landing preparation corresponding to the runway changes.

- (2) After the landing around 12:19, injured persons asked for help for injuries or sickness mainly by pressing the call buttons at their seats because they concluded medical treatment became possible. This made FAs realize that there were more injured persons. FAs became busy taking care of them. FAs were still trying to find other injured persons and taking care of them when the Aircraft arrived at the gate and paramedics entered the cabin to help the injured person lying on the floor. The fact that many people had sustained injuries gradually became known and repeated ambulance requests were made. As a result, as described in 2.10.3, 15 ambulances carried 43 injured people, giving priority to seriously injured persons, to six hospitals, shuttling a total of 17 times between the airport and hospitals. It was at 15:54 when all rescue activities terminated.

As to the treatment for injured persons, it is considered probable that it took considerably long time to carry all injured person to hospitals because; the situation in the passenger cabin was not accurately grasped and before-landing medical requests were insufficient; increased injured persons required additional ambulances.

### **3.8 CVR Deactivation**

As described in 2.7, the records on the Aircraft's CVR at the time of the accident was erased by overwriting. It is considered highly probable that the overwriting occurred because the PIC did not deactivate the CVR even after the landing, allowing the device to continue recording. It is considered somewhat likely that after the Aircraft arrived at the gate, the PIC's attention was focused on confirming the situation in the lower deck passengers and he did not have the consideration of CVR deactivation. Because the CVR record plays a very important role for clarifying the cause of the aircraft accidents, when he confirmed the condition of the injured persons after landing, the PIC should have considered the possibility of an accident and deactivated the CVR, as required in the FOM described in 2.11.

### **3.9 Fastening Seat Belts**

According to the statements in 2.9.2, it is considered probable that passengers suffered injuries when they were thrown upward from the aisles or their seats, or they were about to be thrown upward and they had their head, chest or other body parts hit mainly against the ceiling and the seats, because they were not seated or did not fastened their seat belts, or even if they did it was done inappropriately. When the seat belt sign was illuminated, passengers have to be seated and fasten their seat belts in an appropriate manner. If the seat belt is fastened at an inappropriate position or the belt was loose, and particularly when an aircraft pitches, it is considered probable that the body escaped from the seat belt, lifts in upright posture or bumps against the seat and other things because the attitude of the body may change within the loose bind of the seat belt. The seat belt, which must be worn as a device to avoid injuries caused by abrupt aircraft pitching and rolling, has to be tightly fastened over the lower position of the waist.

According to the statements in 2.1.2 and 2.9.1, it is considered highly probable that when turbulence was anticipated, the PIC made PAs that they should fasten their seat belts and the seat belt sign was illuminated. But according to the statements in 2.9.2, it is considered somewhat likely that some passengers were not aware that the seat belt sign had been illuminated.

### **3.10 Preventive Measures**

Considering the seat belt status as described in 3.9, the Company should give instructions to its FAs first of all so that they will have common understanding about the indication of the seat belt sign and then, it should take measures to call passengers' attention to the need of fastening seat belts properly while paying attention to the lighting up of seat belt sign and other signs and carefully listen to in-flight announcements.

When aircraft is anticipated to encounter turbulence, the cockpit crew should turn on the seat belt sign at the earliest possible time so that FAs may have enough time to finish their duties before the encounter, as advised in the FAM described in 2.11, because a lot of time is necessary for them to provide services to passengers, clean up and confirm the safety of passengers.

In the pre-flight briefing, FAs were informed by the PIC of the possible turbulence and the need to be seated during the descent. Therefore, FAs should have planned to finish in-flight services well before the encounter and if the situation required, they should also have discontinued or canceled in-flight services, as described in the FAM described in 2.11. When the seat belt sign is illuminated, FAs are required to urge non-seated passengers to be seated and perform safety checks mainly by confirming their seat belt fastening manner. In-flight service plan must be prepared considering the necessary time for doing these things.

#### **4. PROBABLE CAUSES**

It is considered highly probable that this accident occurred when the Aircraft pitched greatly upon encountering a turbulence during its descent through a turbulent airspace of convective clouds near the front and below the jet stream, causing serious injuries to four passengers in the aft cabin section: who were not seated; who were not being buckled up; or if done so, who did it in an inappropriate manner.

It is considered somewhat likely that the following factors contributed to the serious injuries of aft cabin passengers: safety of passengers was not fully confirmed in the aft cabin section during the time frame between the seat belt sign illumination and the abrupt big aircraft pitching; and the aft cabin was exposed to a stronger negative vertical acceleration compared to the forward.

Figure 1 Estimated Flight Route

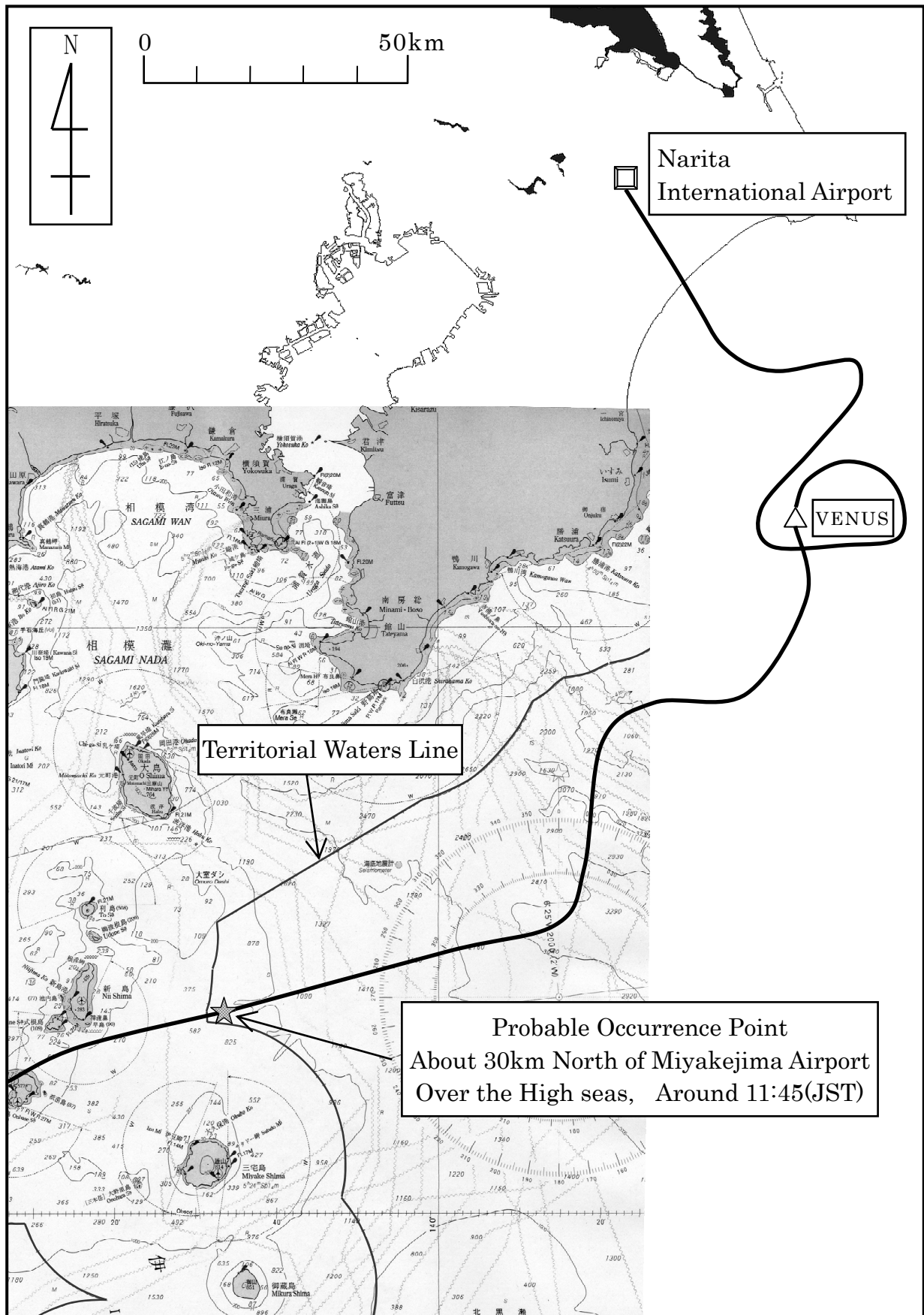

Figure 2-1 DFDR Records (1)

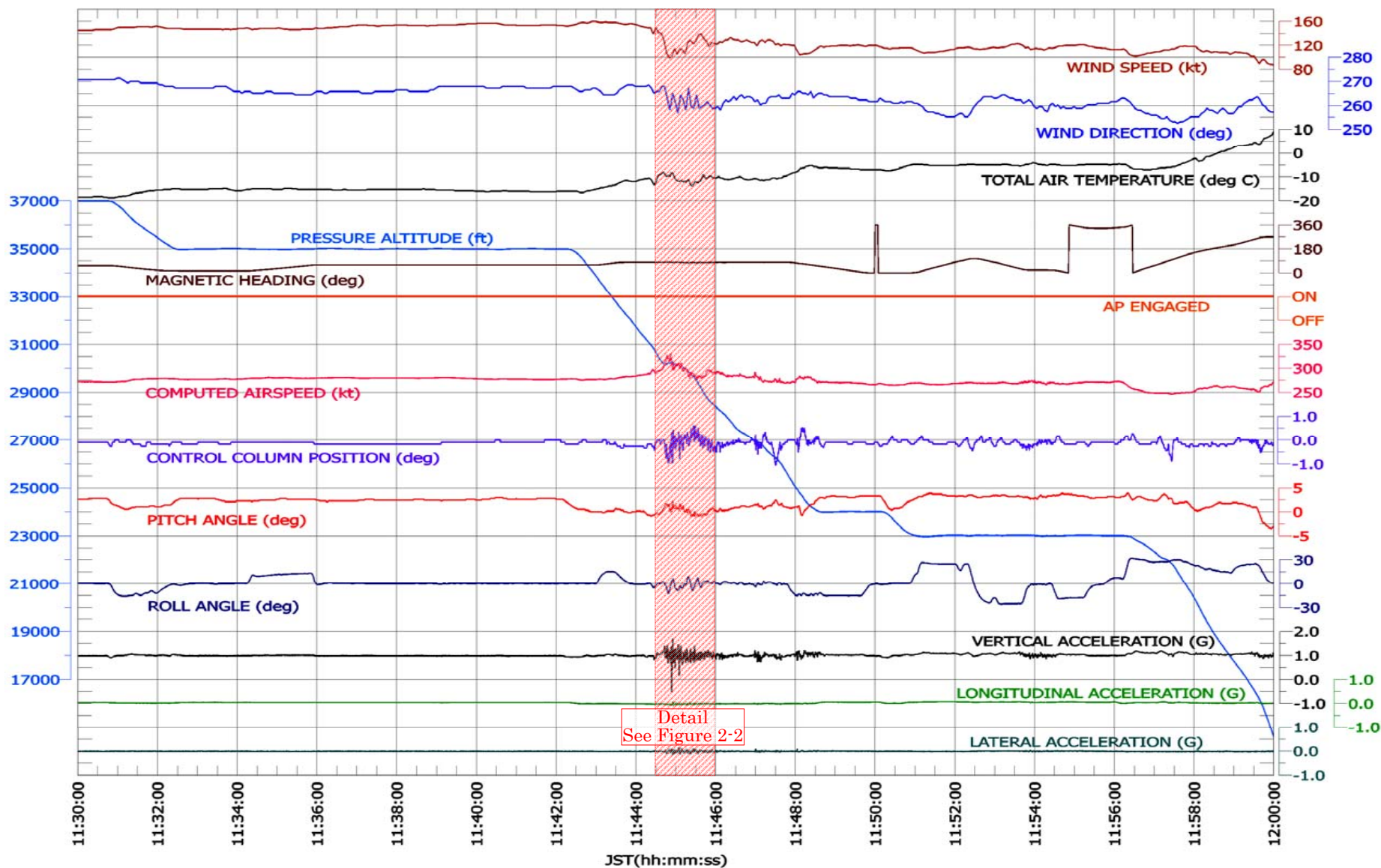

Figure 2-2 DFDR Records (2)

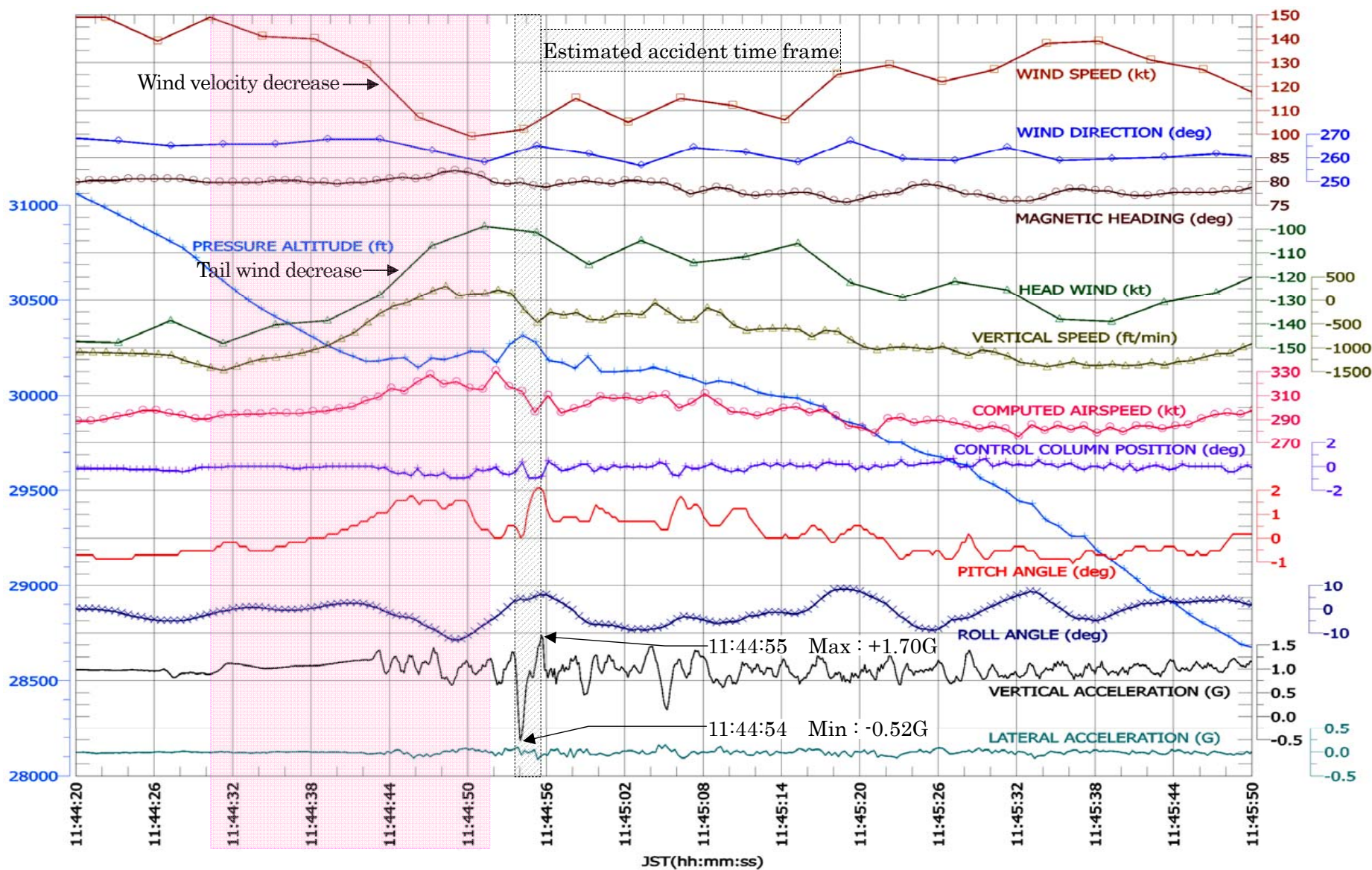



Figure 3 Seat Locations of Injured Persons

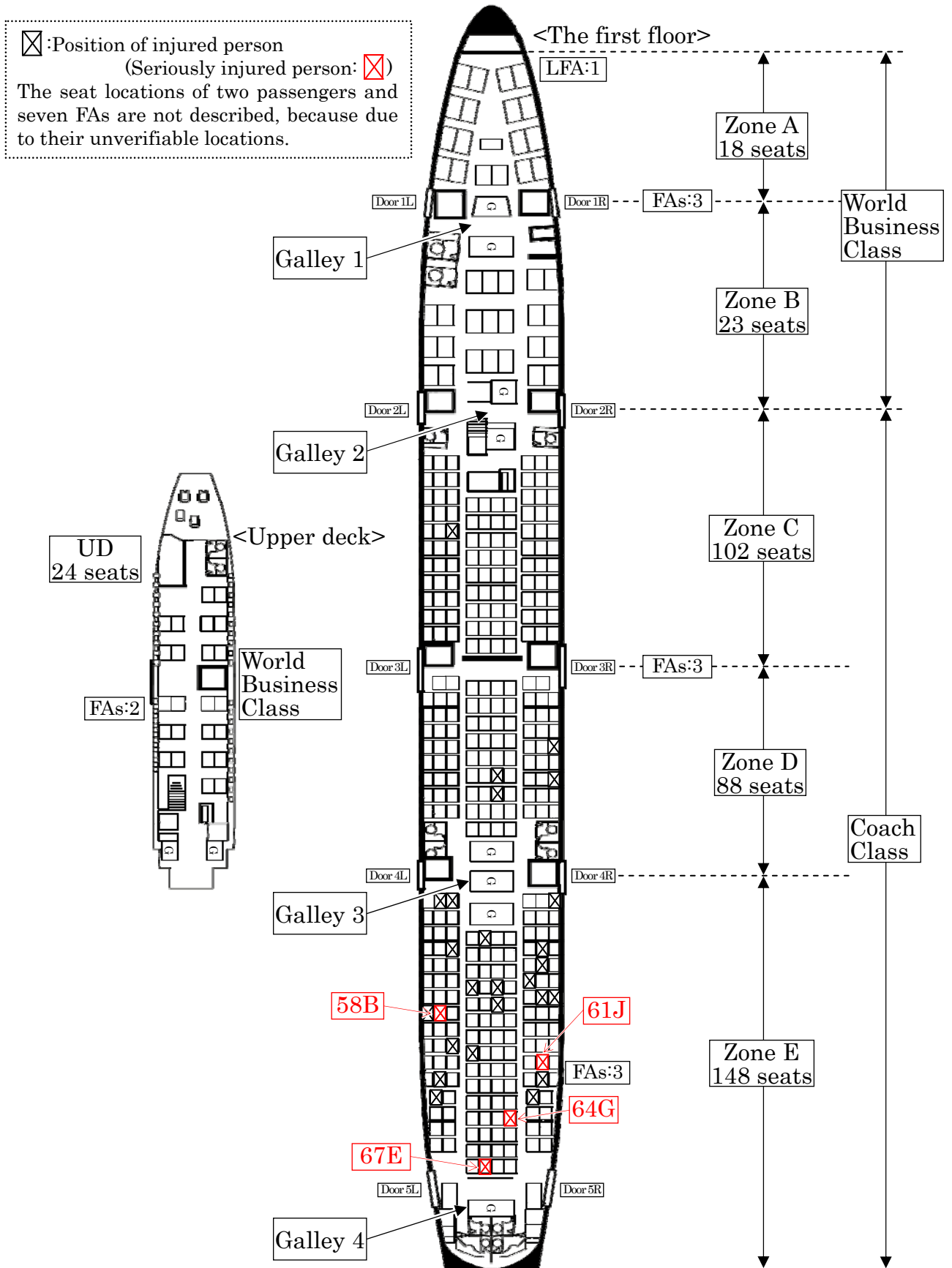
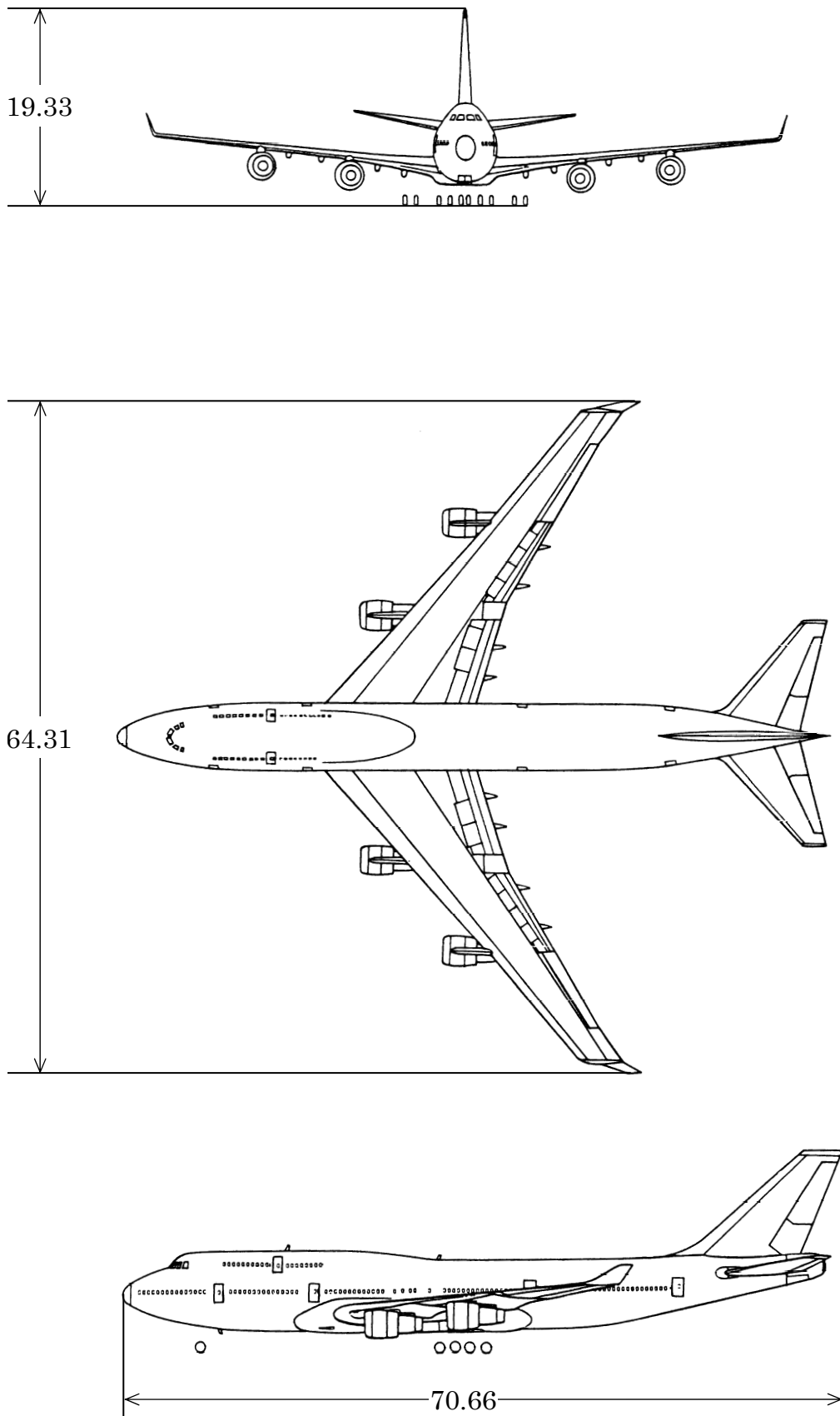

Figure 4 Three Angle View of Boeing 747-400

Unit:m



# Figure 5 Asia-Pacific Surface Analysis

0900JST 20 FEB 2009

Some information was overlaid onto the JMA document.

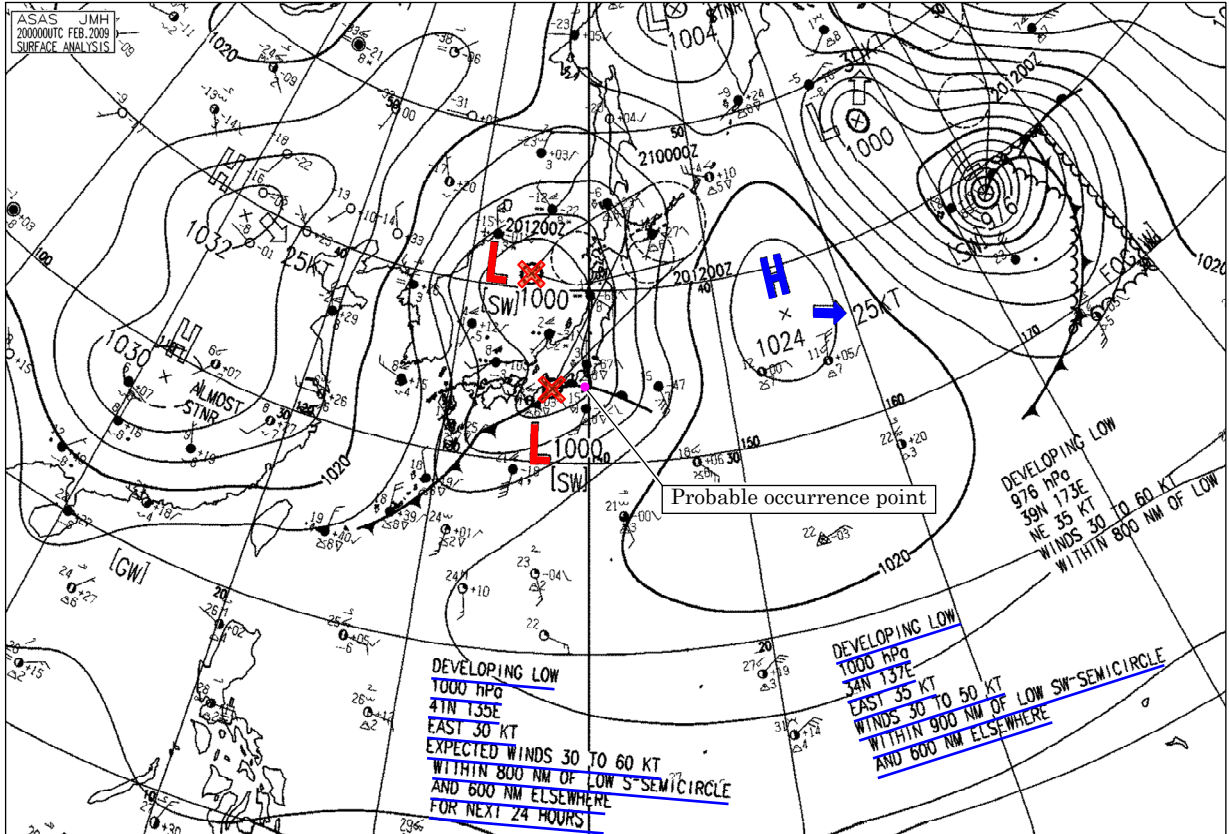

# Figure 6-1 Upper Analysis Chart (AXFE578)

0900JST 20 FEB 2009 850hPa TEMP/WIND 700hPa VERTICAL FLOW

Some information was overlaid onto the JMA document.

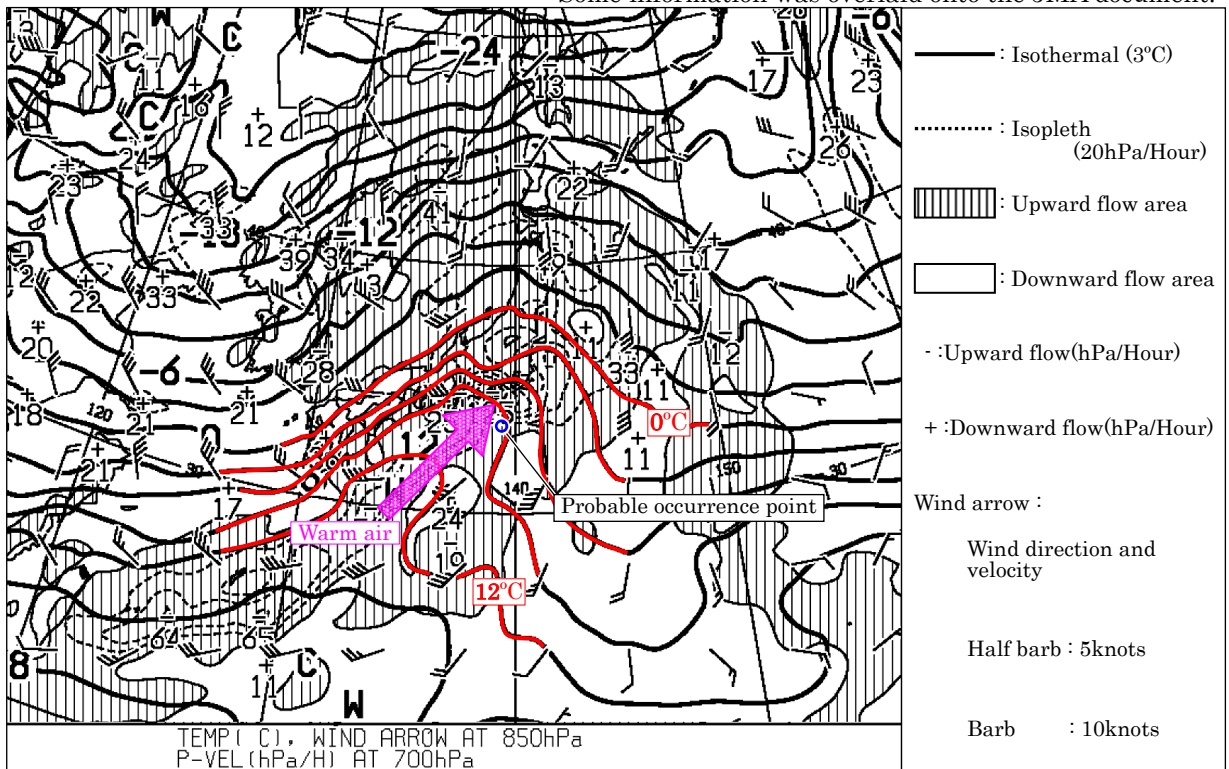

# Figure 6-2 Upper Analysis Chart (AUPQ35)

0900JST 20 FEB 2009 300hPa Surface analysis chart

Some information was overlaid onto the JMA document.

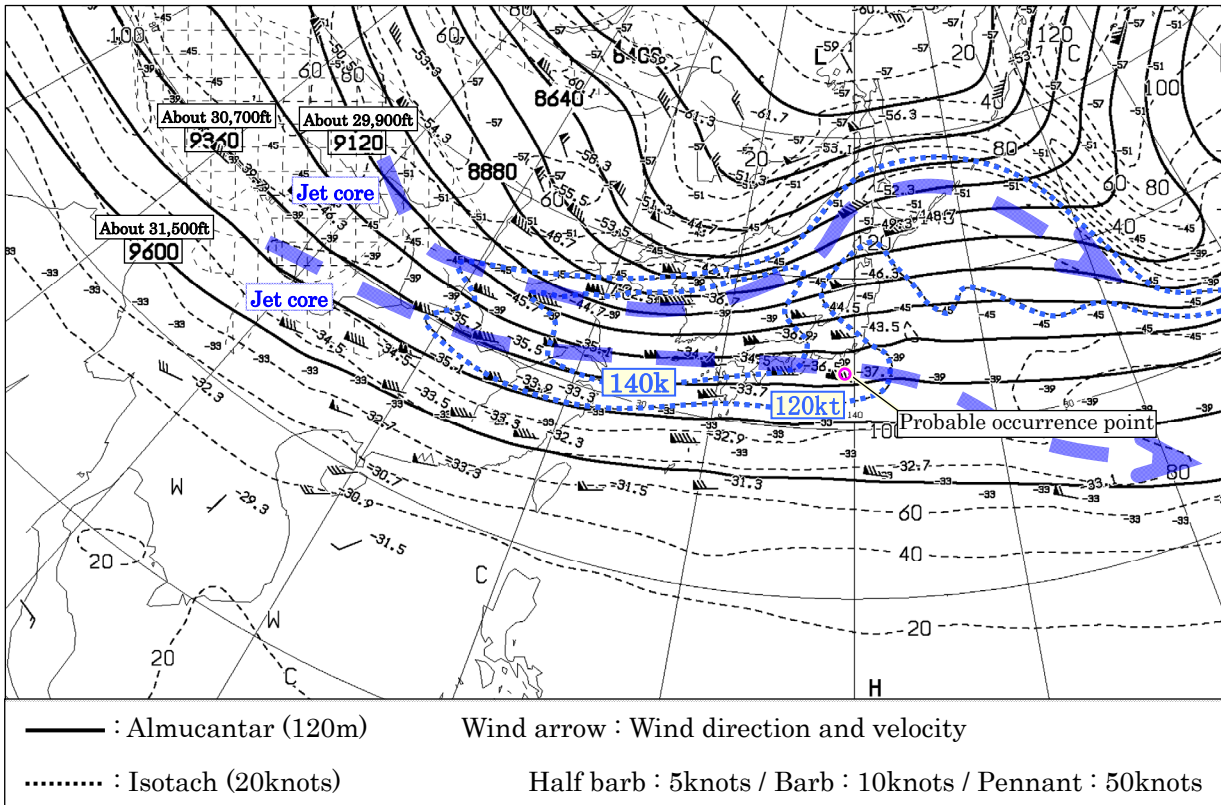

# Figure 7 Meteorological Satellite Imagery (Visible)

1136JST 20 FEB 2009

Some information was overlaid onto the JMA document.

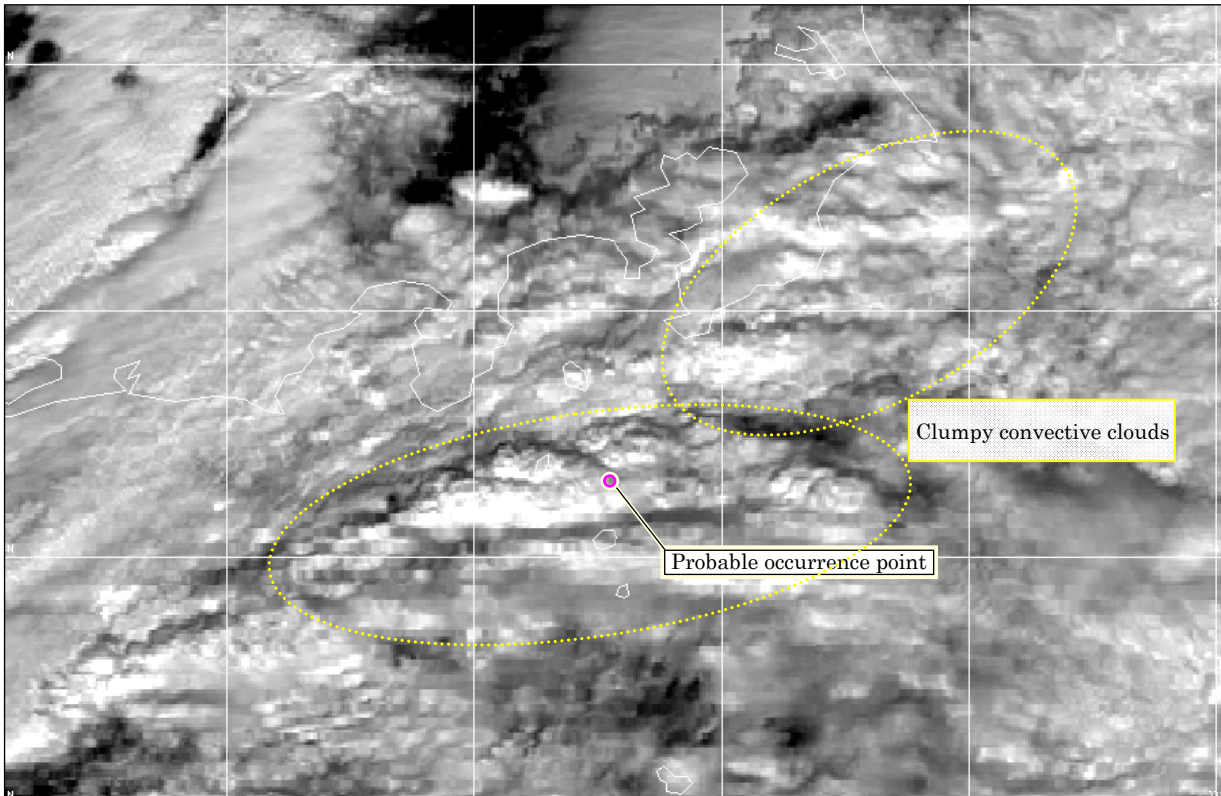

# Figure 8 Weather Radar Imagery

1140JST and 1150JST 20 FEB 2009 Echo strength

Some information was overlaid onto the JMA document.

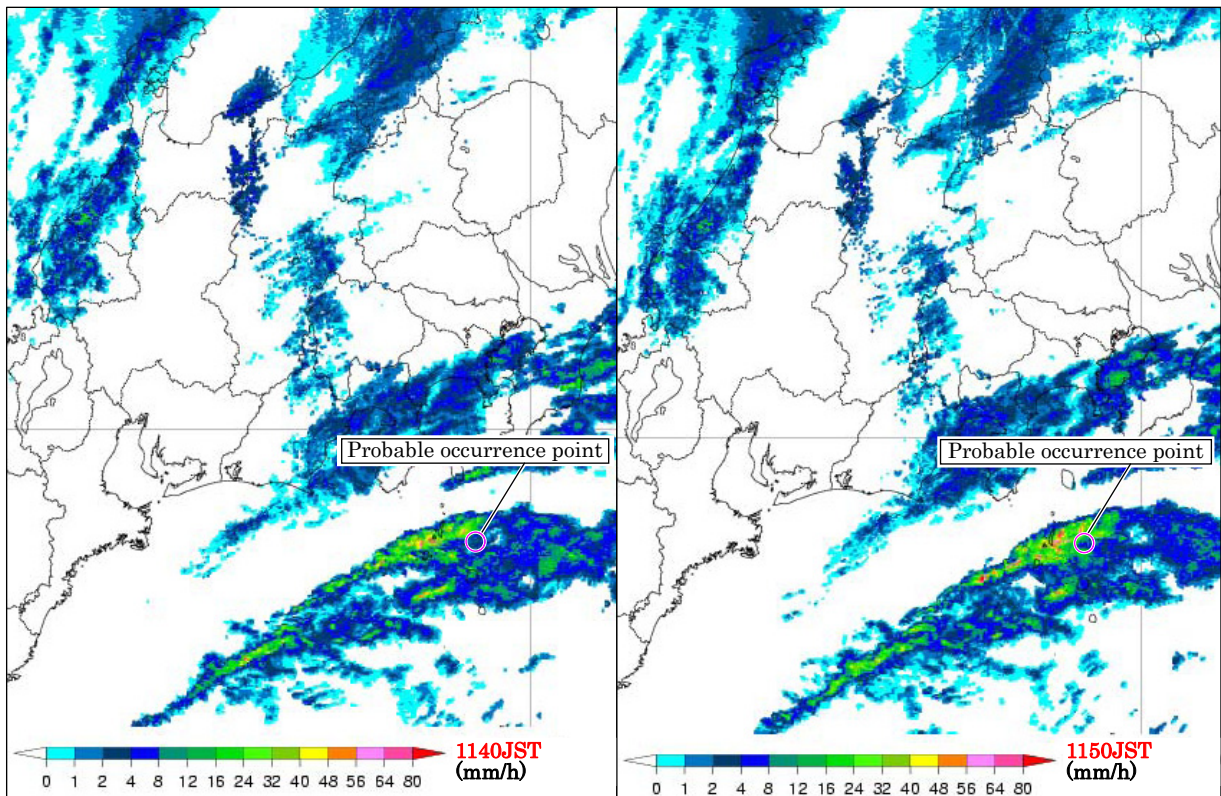

1140JST and 1150JST 20 FEB 2009 Echo top height

Some information was overlaid onto the JMA document.

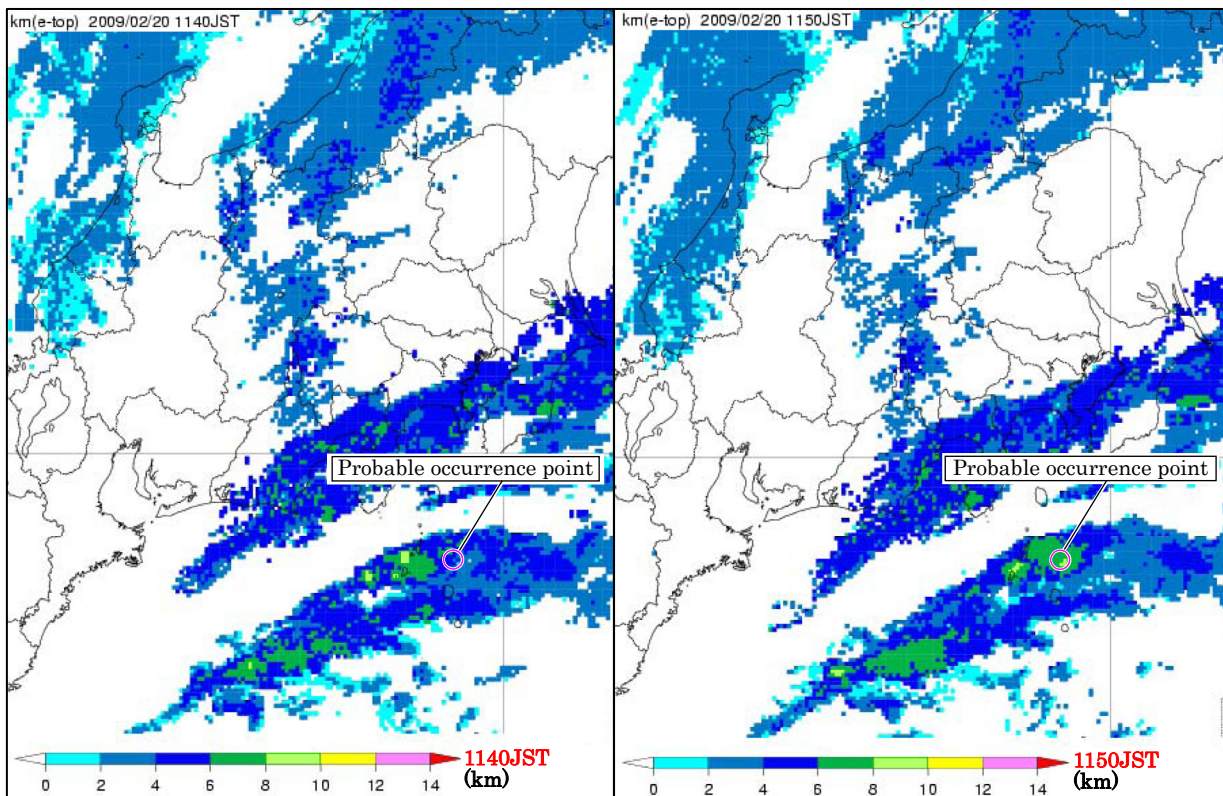

# Figure 9 Relevant Satellite Cloud Information Chart

1200JST 20 FEB 2009

Some information was overlaid onto the JMA document.

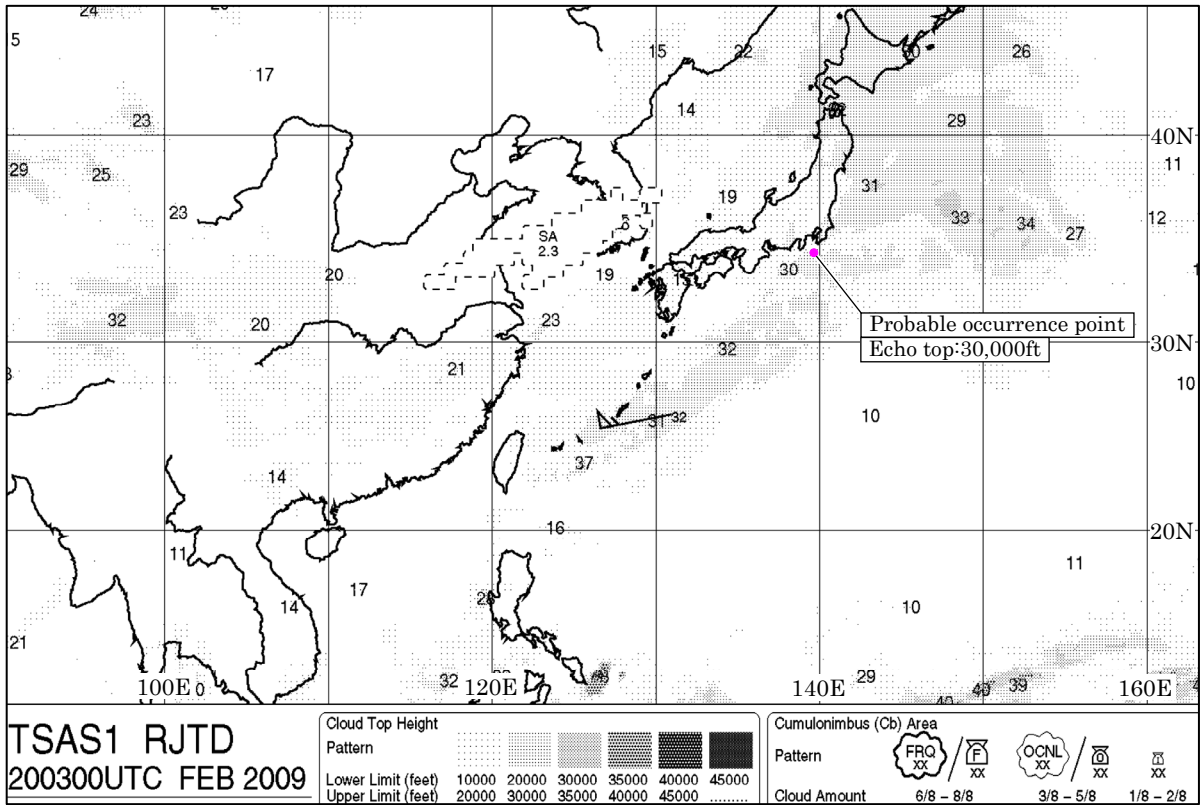

# Figure 10 Hourly Analysis Chart

1200JST 20 FEB 2009 (Longitude 140° E)

Some information was overlaid onto the JMA document.

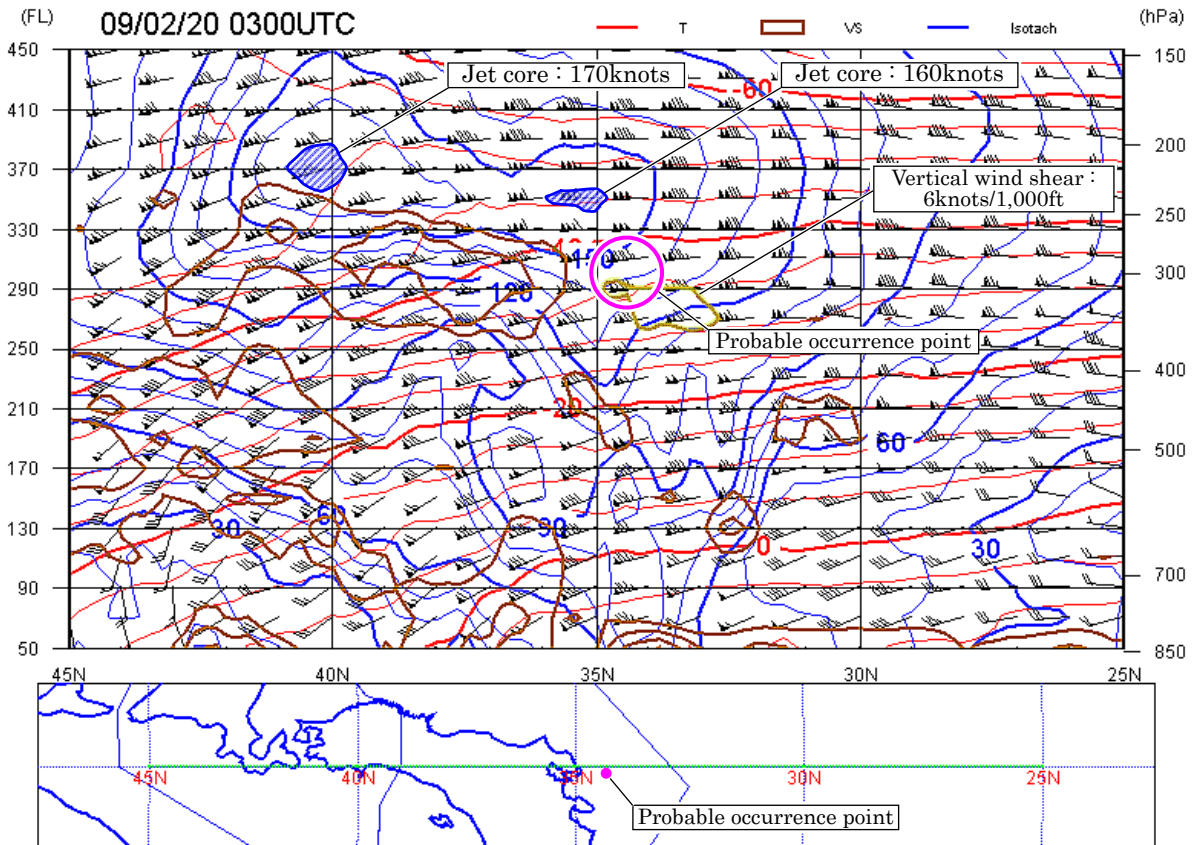

Photo 1 The Aircraft



## Photo 2 Damaged Components

Cabin ceiling



Armrest

Lavatory ceiling





# Attachment 1 ATC Communications Recors

LEGEND ACC: The Tokyo Area Control Center

### : Incomprehensible transmission

Japan  
Standard  
Time

JST	From	Communications
11:30:18	ACC	NWA2, descend and maintain FL350, commence descent for traffic.
11:30:24	NWA2	OK, NWA2, understand 350, we need the left turn to avoid CB, ah must ### turn 040?
11:30:32	ACC	OK, NWA2, 040 approve and descend and maintain FL350, now.
11:30:37	NWA2	OK, descending now, 040 on a heading, NWA2.
11:32:00	NWA2	NWA2, need uh 0 headi, 020 heading.
11:32:02	ACC	NWA2, turn left heading 020.
11:32:04	NWA2	Thank you, NWA2.
11:33:54	Unknown	###
11:34:01	ACC	Station calling say again.
11:34:02	NWA2	OK, NWA2 can take, uh heading 07 Miyakejima, now.
11:34:07	ACC	NWA2, recleared direct ORGAN.
11:34:10	NWA2	OK, direct ORGAN, NWA2.
11:37:31	NWA2	Tokyo, NWA2.
11:37:34	ACC	NWA2, go ahead.
11:37:35	NWA2	We need to turn left 20 degrees again for another CB.
11:37:38	ACC	NWA2, ah...request heading.
11:37:43	NWA2	###
11:37:51	ACC	NWA2, say again.
11:37:54	NWA2	heading 045, 050, either one.
11:37:57	ACC	NWA2, how about right turn.
11:37:59	NWA2	No.
11:38:01	ACC	Roger, ah...NWA2, ah...reque..ah..say present heading.
11:38:05	NWA2	OK, NWA2, we'll maintain this heading.
11:41:26	ACC	NWA2, descend to reach FL180 by MAMAS.
11:41:31	NWA2	OK, 180 by MAMAS, NWA...NWA2.
11:42:45	ACC	NWA2, fly heading 080.
11:42:48	NWA2	080, NWA2.
11:47:40	ACC	NWA2, descend and maintain, ah...fly heading ah correction, turn left heading 360, descend and maintain FL240.
11:47:47	NWA2	240, 360, NWA...ah...02.

## Abbreviation

ACARS	:Aircraft Communication Addressing and Reporting System
CVR	:Cockpit Voice Recorder
DFDR	:Digital Flight Data Recorder
DME	:Distance Measuring Equipment
FAM	:Flight Attendant Manual
FL	:Flight Level
FMC	:Flight Management Computer
FOM	:Flight Operations Manual
MAC	:Mean Aerodynamic Chord
NTSB	:National Transportation Safety Board
PF	:Pilot Flying
PM	:Pilot Monitoring
TACAN	:Tactical Air Navigation System
VOR	:Very High Frequency Omni-Directional Radio Range
VORTAC	:VOR and TACAN

One pound	:0.4536 kilograms
One foot	:0.3048 meters
One knot	:1.852 kilometers per hour (0.5144 meters per second)
One nautical mile	:1,852 meters