

AA2004-1

AIRCRAFT ACCIDENT INVESTIGATION REPORT

ALL NIPPON AIRWAYS FLIGHT 569
BOEING 767-300, JA8274
OVER THE SEA 16 NM S.E. OF KOCHI AIRPORT, JAPAN
SEPTEMBER 27, 2002

March 26, 2004

Aircraft and Railway Accidents Investigation Commission
Ministry of Land, Infrastructure and Transport

The investigation for this report was conducted by Aircraft and Railway Accidents Investigation Commission, ARAIC, about the aircraft accident of All Nippon Airways Boeing 767-300 in accordance with Aircraft and Railway Accidents Investigation Commission Establishment Law and Annex 13 to the Convention of International Civil Aviation for the purpose of determining cause of the aircraft accident and contributing to the prevention of accidents and not for the purpose of blaming responsibility of the accident.

This English version report has been published and translated by ARAIC to make its reading easier for English speaking people those who are not familiar with Japanese. Although efforts are made to translate as accurate as possible, only the Japanese version is authentic. If there is difference in meaning of the texts between the Japanese version and the English version, texts in the Japanese version are correct.

Junzo Sato,
Chairman,
Aircraft and Railway Accidents Investigation Commission

AIRCRAFT ACCIDENT INVESTIGATION REPORT

**ALL NIPPON AIRWAYS FLIGHT 569
BOEING 767-300, JA8274
OVER THE SEA 16 NM S.E. OF KOCHI AIRPORT, JAPAN
AT ABOUT 20:25 JST, SEPTEMBER 27, 2002**

February 18, 2004

**Decision by the Aircraft and Railway Accidents Investigation
Commission (Air Sub-committee Meeting)**

Chairman	Junzo Sato
Member	Ryouhei Katsuno
Member	Susumu Kato
Member	Sumio Matsuura
Member	Yukiko Kakimoto
Member	Kozaburo Yamane

1. PROCESS AND PROGRESS OF THE ACCIDENT INVESTIGATION

1.1 Summary of the Accident

On Friday September 27, 2002, a Boeing 767-300 of All Nippon Airways, registration No.JA8274, departed from Tokyo International Airport at 19:28 (JST) as scheduled passenger flight 569 to Kochi Airport. The aircraft was descending in accordance with instrument flight rule over the sea approximately 16nm southeast of Kochi Airport to land, at around 20:25 at an altitude of 2,600ft, it was shaken suddenly and violently resulting in injuries to passengers.

There were 296 persons on board flight 569 — 288 passengers (including an infant), the Captain and seven other crewmembers. Two passengers were seriously injured and one passenger was slightly injured.

1.2 Outline of the Accident Investigation

1.2.1 The Organization of the Investigation

On September 28, 2002, the Aircraft and Railway Accident Investigation Commission (ARAIC) assigned an Investigator-in-Charge and two other investigators with responsibility for investigating this accident. Subsequently, a further air accident investigator was assigned on October 7, 2002.

1.2.2 Accredited representative and adviser by Foreign Authorities

An Accredited Representative, from the United States, the state of design and manufacture of the aircraft, participated in the investigation of this accident.

1.2.3 Cooperation by the National Aerospace Laboratory (NAL)

The Flight Experiment Group of Flight Systems Research Center, National Aerospace Laboratory of Japan, assisted in the analysis of the accelerations experienced at each seat in the aft cabin.

1.2.4 The Implementation of the Investigation

The investigation proceeded as follows.

September 28, 2002	Investigation of the aircraft and collection of witness statements.
September 30, 2002–October 8, 2002	Collection of witness statements.

September 30, 2002–January 9, 2003	Analysis of flight recorders.
January 20, 2003	Investigation by flight test.
January 22, 2003–April 30, 2003	Analysis of accelerations on cabin seats.

1.2.5 Hearings from Persons relevant to the Cause of the Accident

Hearings were held.

1.2.6 Inquiry into the participating country for this investigation

Inquiries were held.

2. FACTUAL INFORMATION

2.1 Flight History

2.1.1 Flight History based on the DFDR Data and ATC Radio Communications Voice Recordings, etc

On September 27, 2002, the aircraft, a Boeing 767-300 of All Nippon Airways (ANA, hereinafter referred to as the said company), registration JA8274, took off from Tokyo International Airport at 19:28 (JST) operating as ANA scheduled flight 569 to Kochi Airport.

In the cockpit were the Captain, who occupied the left seat and was acting as PF (Pilot Flying), and the First Officer who occupied the right seat and was acting as PNF (Pilot Not Flying).

An outline of the aircraft's flight plan which submitted to the Tokyo International Airport Office of the Civil Aviation Bureau was as follows:

FLIGHT RULES: IFR, DEPARTURE AERODROME: Tokyo International Airport, ESTIMATED OFF BLOCK TIME: 19:00, CRUISING SPEED: 501kt, CRUISING ALTITUDE: FL260, ROUTE: KZE (KISARAZU VOR/DME) – URAGA–OCEAN–YZ (YAIZU NDB)–CELLO–Y21 (RNAV ROUTE)–KEC (KUSHIMOTO VORTAC)–A1 (AIRWAY)–JAKAL – KRE (KOCHI VOR/DME), DESTINATION AERODROME: Kochi Airport, TOTAL EET: 1 hours 1 minutes, ENDURANCE: 4 hours 14 minutes, ALTN AERODROME: Tokyo International Airport.

An outline of the flight history based on data from the Digital Flight Data

Recorder (DFDR), recordings of ATC radio communications and other sources, is as follows:

(1) The Progress of the Flight until the Accident Occurred

The aircraft left from the departure gate at 18:59, and after took off at 19:28, and then reached its cruising altitude at FL260 at about 19:40.

After the aircraft had passed over KEC, it began its descent following an instruction from Tokyo ACC. Subsequently during the descent, the aircraft was instructed to fly direct to KRE.

At 20:15:09, the aircraft reported to Kochi Terminal Control (hereinafter called Kochi approach) that it was passing FL145 descending to 12,000ft, and that it had received ATIS(Airport Terminal Information Service) information YANKEE.

Between about 20:15 and 20:21, the aircraft changed heading twice toward the south and made a one turn to the west further.

At 20:21:54 Kochi Approach instructed the aircraft to turn right heading 330 degrees to intercept the localizer.

At 20:24:01, when the aircraft was approximately 20nm southeast of Kochi Airport, Kochi Approach cleared it for ILS approach to runway 32.

From 20:24:40 changes began to the aircraft's lateral and vertical accelerations, and thereafter the DFDR continuously recorded significant changes.

Between 20:25:02 and 20:25:03, the DFDR recordings showed that the aircraft descended approximately 100ft from 2,600ft to 2,500ft in the one second interval . At 20:25:03, while the aircraft was approximately 16nm from the runway of Kochi airport at an altitude of 2,600ft and descending, DFDR recordings indicated that lateral acceleration was as 0.4G to the left, vertical acceleration was 1.6G upward, and roll angle was 8.1° right. One second later at 20:25:04, the recordings indicate that lateral acceleration was 0.1G to the right, vertical acceleration was 0.6G downward and the roll angle was 9.7° left.

(2) The Progress of the Flight After the Accident Occurred

At 20:25:17 Kochi Approach Control asked the aircraft whether it would be necessary to deviate from the final approach course.

At 20:25:24 the aircraft informed Kochi Approach that it had encountered fairly severe turbulence and intended to deviate to the left of the course, and

then departed from the course to the left.

At 20:27:59, at approximately 5.3 nm southeast of Kochi Airport at an altitude of approximately 1,800ft, the aircraft established contact with Kochi Airport Control (hereinafter Kochi Tower).

At 20:28:03, Kochi tower cleared the aircraft to land on runway 32.

At 20:28:05, while the First Officer was communicating with Kochi Tower, the Captain initiated a missed approach at 5nm southeast of Kochi Airport at an altitude of 1,700ft. At 20:28:17, the aircraft reported the missed approach to Kochi Tower while climbing.

While climbing at 20:29:12, the aircraft requested to Kochi Tower to continue the climb to 5,000 ft due to rough air.

Thereafter, the aircraft continued to hold for around 40 minutes until the active echo that existed around the approach area had moved north and passed over the airport, and then landed at Kochi Airport at 21:23.

Considering overall the significant acceleration changes recorded by the DFDR and the contents of the statements described in section 2.1.2, it is concluded that the accident occurred at around 20:25.

(See Figs. 1, 8, 9, 10-1 and 10-2)

2.1.2 Statements of the Flight Crew, the Assistant Dispatcher at ANA's Kochi Airport Office, and Several Passengers

(1) The Captain

“At around 18:00 I received the briefing from the company’s dispatcher at Haneda Airport (the “Haneda dispatcher” below). Around Kochi Airport, an echo was moving from west to east and moving such that it might pass briefly over the airport. There was no specific advice on turbulence on the Kochi Airport approach. According to the aircraft’s time schedule the arrival time at Kochi Airport was 20:15, the difference was only 15 minutes from the closing time of Kochi Airport, which was until 20:30, and because extra time is necessary for take off from Haneda, reaching at Kochi even at 20:30 was going to be tight. A high-speed enroute cruise was therefore planned. Also, there was extra fuel (Note: 1) to hold for more than one hour over Kochi. Although I had doubts as to whether it was necessary to load extra fuel for more than one hour of flight, fuelling had already begun so I assented.

While there was no turbulence on the route, but anticipating that there

might be turbulence during the descent, at around Kushimoto I notified the passengers that we planned to start the descent in 10 minutes but because turbulence was expected during the descent they should finish using the lavatories early. During descent I changed the heading slightly to the south because of an echo on the north side of the Cape of Muroto. Because of continuous light turbulence, I instructed the cabin attendants (CA) that they should stop the 10 minutes before landing cabin safety check and only the cabin announcement should be made.

I used the on-board weather radar to watch for echoes within a range of 10–20 nm, and I used from -1° to $+4^{\circ}$ – 5° of tilt.

The aircraft started being buffeted on the approach and the on-board weather radar showed an echo to the south of Kochi Airport and I had some doubts because this different from the echo location information received by the First Officer from the assistant dispatcher at the company's Kochi Airport office (the "Kochi assistant Dispatcher" below).

While approaching on the Kochi Airport final approach course I contacted Kochi Approach, and while I turned the [autopilot] heading selector knob to avoid the green echo on the weather radar, the echo to the west of the airport included some red areas which I thought we might get close to if we didn't descent quickly.

We moved to join the ILS final course about 30nm from the runway 32 final. As an echo could be seen on the weather radar 20–15nm ahead and was on the course, though we received has been 'cleared for ILS' by Kochi Approach, I passed once further to the west to keep away from the echo.

About 8.5nm before from the runway, we set gear down and flap 20° , established on the localizer at 7nm and at 6.5nm set flap to 30° . I made the approach using autopilot and auto-throttle. V_{REF} was 130kt and V_{TG} was 137kt.

At around 20:27, at around 5.5nm before from the runway and an altitude of around 1,600ft to 1,700ft, while the First Officer was talking with the tower we encountered 'Moderate' to 'Moderate plus' turbulence. Even though the autopilot was engaged at the time, we rolled to 20° – 25° and the descent rate became around 1,500–2,000ft/min. The airspeed was 145–150kt. Because there was such a large change in attitude just after we had joined the glide slope, I immediately made a missed approach.

When I made the missed approach, I pressed go-around switch and left it to the autopilot at first, but once we had reached climb pitch I disconnected the

autopilot. During the climb to 5,000ft I reengaged with autopilot and after informing ATC regarding the turbulence we began holding. After that, the echo moved to the north and I thought it would not affect the approach so from 21:10 we left the holding pattern and began to descend. We landed at Kochi Airport and stopped at the spot at 21:27.

The aircraft was not equipped with a predictive windshear warning system.

After landing to Kochi, I heard from a CA that a passenger had hit his right side on an armrest, but she did not know at what time it had happened.

According to the CA, it was when the aircraft was buffeted at around 20:25, but at 20:25 there had been no sign of speed or pitch changes on the aircraft's instruments. I had felt that the buffeting was the strongest at around 20:27, when I made the missed approach.

Generally as a characteristic of this aircraft, the aft cabin tends to be experience more shaking than the center cabin because of the long moment arm from the center of gravity. I was often told by CA that even when the seat belt signs have been switched off they are unable to carry out the in-flight service in the aft cabin because of the motion.”

Note 1: According to the operations manual, “Extra fuel” means the fuel which is loaded other than the required minimum fuel (“the required minimum fuel” must meet to the Aviation Law) when the captain and the flight dispatcher consider it for the safest operation and increase efficiency of the operation.

Such an additional fuel will be loaded for the reasons of weather conditions of the destination, alternate airport, or enroute.

(2) The First Officer

“At around 20:10, according to the information from the Kochi assistant dispatcher, there were echoes over the airport and 30nm east of the airport which were moving north relatively quickly and a previous flight had reported ‘light to light plus’ turbulence in cloud during descent. There was no information on the altitude of echo included in the report. I was also advised to be aware of wind changes as the wind changed from a 10kt tail wind at 1,000ft above ground level (AGL) to the same wind conditions as on the surface below 500ft.

During the approach to Kochi I did not observe any St. Elmo's fire (Note 2),

flashes of lightning nor lightning strikes.

While we were vectoring from Kochi Approach, the Captain did not fly into any areas where there were obvious echoes shown on the on-board weather radar. There was a comparatively large echo accompanied by another echo in the area in which we were being vectored onto final. If we had maintained heading we would have passed through the middle of them, but because we were approaching the echoes the Captain flew the approach bypassing to the left of the echoes.

The aircraft intercepted the localizer course on final, and a green colored echo was displayed on the final approach course 5.5nm to the southeast of Kochi Airport. Kochi Approach asked us if it would be necessary to deviate from the localizer course. Although the Captain had established on the localizer course once, because we would encounter the echo he bypassed it by turning the heading to the left (an approximately 30° cut) and later recaptured the localizer course and also the glideslope.

While I was contacting Kochi Tower and receiving landing clearance, the Captain made a missed approach.

I don't remember the exact time, but during the five minutes before we made the missed approach, there was an instant sideways motion that I had not experienced before. I felt it was between 'moderate' to 'severe' in the turbulence code classifications. The sideways motion felt more like a rapid sideways sliding than a roll. There was not much change in the roll angle, and the pitch angle oscillated between 1°–2°. Although I had fastened my shoulder harness, I had a strong feeling of the aircraft being hit from the side."

Note 2: What is generally called 'St. Elmo's fire' by flight crews is a phenomenon in which electrically charged raindrops hitting the wind-shield causing flashes of electrical discharge that float on the water flowing on the surface of wind-shield, and can also be induced on the aircraft wing tips.

(3) The Chief Purser (Referred to below as "CP")

"When we started the landing phase, on the instruction of the Captain the pre-landing safety check was carried out by a making a cabin announcement .

At around 20:24, the aircraft was shaken twice with a sound of 'Gohng, Gohng', and although I was sitting on the left forward L1 seat with my shoulder harness fastened, my upper body moved sideways so on the first

shake I put my right hand on the door and on the second shake I put my left hand on the video stowage. (See Figs. 3)

I have experienced up-and-down movement before but this was the first time I had experienced sideways shaking. I received a report from a CA aft that passengers seated aft were pretty frightened, and as far as I could see from the L1 seat several passengers were appearing agitated, so I made a cabin announcement that passengers should re-confirm that their seat belt were fastened and that there was no effect on the flight, etc.

At 20:28, immediately after the aircraft started to make a missed approach, I made a cabin announcement that we were going around.

After the aircraft had circled for about ten minutes, when I went to check the condition of the cabin, the seat belt signs were still on so I made a cabin announcement telling the passengers to remain in their seats.”

(4) CA

“I was sitting on the left aft L2 seat. The seat belt signs were on and some time after the seat belt signs had been switched on I briefly felt some vertical motion, and after that some sideways motion. Although I was sitting facing the passengers with my shoulder harness fastened, I felt as though I was being shaken from around my hips.

As the shaking was quite severe, I checked the state of the passengers but the passengers in my sight had their seat belts fastened. I thought they would be thrown out of their seats unless their seat belts were fastened.”

(5) The Kochi Assistant Dispatcher

“At around 19:40, I received a telephone call from the Haneda Dispatcher who was responsible for the aircraft in cruise and for communicating with it, and he asked me to advise the Captain about the echoes.

I contacted the aircraft at around 20:10, and notified it that the parking spot was No. 3, the surface wind was varying from 330°–020° at 5–6kt, and that the radar echo information based on an observation at 20:00 was that there were echoes 10nm southwest and around 10nm southeast of the airport moving slowly north. I also informed that there was light rain at Kochi Airport, that a previous flight that had landed at around 18:20 had reported ‘light’ to ‘light plus’ turbulence during descent, and that a south wind down to 1,000ft shifted around to the east between 1,000ft and 500ft, and below 500ft was the same as the surface wind. Although I transmitted to be

careful of turbulence at the boundaries of the wind change, I did not inform the strength of the echoes.

I did not know because I did not hear how high the echo was and what the level of turbulence was when the previous flight landed. Flights arriving at Kochi Airport since around noon had been reporting turbulence at around 3nm on final. When the previous flight landed the echo had been further to the south. A low pressure over the south of Shikoku was developing while moving northeast, and was therefore accompanied by echoes. At the time of accident, although there were echoes coming near the airport and the weather had deteriorated, I had not expected it to become so bad.

At around 20:36, while the aircraft was holding over Kochi, I reported echo information, and at that time I confirmed it with the Airport Branch of the Kochi Area Meteorological Observatory then contacted the aircraft again to send the information. I thought the echoes would pass within 30 minutes. I received no reports from the aircraft regarding passengers and the situation in the cabin. After that, the captain asked me that he wanted to write a report (INCIDENT /EMERGENCY REPORT) at the Airport Office after the captain deplaned. So I handed him a blank form for the report.

(6) The Statements of Several passengers

The following is a summary obtained by combining the statements of several of the passengers.

The forward cabin

“There was an announcement from the Captain that we were preparing to land but there would be turbulence and so seat belts should be fastened. All the CA also took to their seats. At that time the aircraft suddenly started to shake sideways and it felt as if we were rolling and had been thrown sideways. The upper half of my body felt as if it was being pushed from the side and I felt that the aircraft was inclined to the right and sliding to the right.

Although I was sitting at a window seat I hardly saw any lights on the ground because of the bad weather. I have experienced aircraft rising and sharply dropping many times, but this time it felt as though the aircraft suddenly moved sideways. There was one severe shake that came like an earthquake directly from below, and it felt like we were being thrust up from below. This was the first time I had experienced such motions.”

The center cabin

“There was an announcement about fastening seat belts, with no particularly special information. The seat belt sign came on and I fastened my seat belt. Suddenly, as the aircraft started preparing to land, there was a sideways motion and the right wing momentarily dropped and then returned. At that time a sharp sideways motion occurred, I don’t know whether from the right or the left. There was a sharp direct sideways movement that felt as it was pushing my body, and immediately afterwards another movement that felt like it was pushing me back again. It was a large enough motion that I hit the armrest but not enough to cause pain.”

The aft cabin

“There were two announcements each from the Captain and the CA about fastening seat belts. The CA also was fastening their seat belts, and after the announcement that we were preparing to land the aircraft started shaking. It didn’t continue for long but the aircraft dropped downwards and was shaking, and finally leaned sharply sideways in an instant.”

(See Figs. 7-1 and attachment)

2.2 Injuries to Persons

Two passengers were seriously injured and one was slightly injured.

2.3 Damage to the Aircraft

There was no damage to the aircraft.

2.4 Crew Information

2.4.1 Flight Crew

(1) Captain: Male, aged 39

Airline Transport Pilot License (Airplane)

Issued October 19, 2000

Type Ratings

Airplane, multi-engine(land)

Issued August 17, 1990

Boeing 767

Issued October 9, 1992

Boeing 747

Issued May 30, 1996

Class 1 Aviation Medical Certificate

Term of Validity	until March 21, 2003
Total flight time	5,506 hours 16 minutes
Flight time during the previous 30 days	50 hours 11minutes
Total flight time on Boeing 767	3,080 hours 49 minutes
Flight time during the previous 30 days	50 hours 11minutes

(2) First Officer: Male, aged 31

Commercial Pilot License (Airplane)	Issued July 24, 1998
Type Rating	
Airplane, single-engine (land)	Issued July 24, 1998
Airplane, multi-engine (land)	Issued December 3, 1998
Boeing 767	Issued December 18, 2000
Instrument Rating (Airplane)	Issued May 25, 1999
Class 1 Aviation Medical Certificate	
Term of Validity	until January 11, 2003
Total flight time	1,367 hours 41 minutes
Flight time during the previous 30 days	60 hours 08 minutes
Total flight time on Boeing 767	1,102 hours 21 minutes
Flight time during the previous 30 days	60 hours 08 minutes

2.4.2 CA

CP : Female, aged 34

Position at the time of accident	L1
Total flight time	10,222 hours

2.5 Aircraft Information

2.5.1 The Aircraft

Type	Boeing 767-300
Serial No.	24005
Date of manufacture	May 20, 1988
Certificate of Airworthiness	No.99-049
Term of validity	until valid data of ANA Maintenance Program Manual

	From March 12,1999
Total time in service	32,498 hours 51 minutes
Flight time since scheduled maintenance	
“C” Check on November 17, 2001	1,980 hours 53 minutes
(See Figs. 2)	

2.5.2 Weight and Center of Gravity

The weight of the aircraft at the time the accident occurred is estimated to have been approximately 270,140lbs, with the center of gravity at 22.3% MAC, both values being within allowable limits (maximum takeoff weight being 288,700lbs, and an allowable range of center of gravity of 11% to 34% MAC for the estimated weight at the time of accident).

2.5.3 Fuel and Lubricating Oil

The Fuel on board was JET A-1. The lubricating oil was ESSO Turbo-Oil ETO2197.

2.6 Meteorological Information

2.6.1 Synoptic Weather

The following weather synoptic for Kochi Prefecture issued by the Kochi District Meteorological Observatory at 17:00 on the day of the accident:

There will be heavy rain in places due to a developing region of low pressure approaching Kochi Prefecture. There will be temporarily heavy rain with thunder in places from tonight (27th) until noon tomorrow (28th).

The following airport weather information was issued by the Kochi airport branch office of the Kochi District Meteorological Observatory at 18:05 on the day of accident:

RJOK (Koch Airport): Airport Weather Information related to thunderstorms No.146

Effective from 18:05 on September 27, 2002 until 03:00 on the 28th.

(Thunderstorm Information):

Thunderstorms are expected to occur between 00:00 on the 28th until 03:00 on the following day, with an hourly rainfall of 15–20mm.

(Other caution advisories)

Lightning, gusts, turbulence, short periods of intense rain,

temporary low visibility, and temporary low ceiling are expected.
(Meteorological elements)

A region of low pressure is approaching the airport and atmospheric conditions are becoming unstable.

Furthermore, according to the Asia Surface Weather Chart of 21:00 on the 27th, a stationary front was off the south of the Japanese archipelago, and a weak low pressure system on the front located near Kyushu was proceeding to the northeast.

(See Fig. 4)

2.6.2 The aviation routine weather report (METAR) around the time of accident was as follows:

Time of Observation	<u>20:00 JST</u>	<u>20:15 JST</u>	<u>20:21 JST</u>	<u>20:40 JST</u>
Wind Direction	310 degrees	290 degrees (varying 250–340)	320 degrees	310 degrees
Wind Speed	10kt	08kt	09kt	06kt
Visibility	4,500m	3,000m	2,800m	2,500m
Current weather	Showers, Mist, Cloud	Showers, Mist, Cloud	Heavy showers, Mist, Cloud	Heavy showers, Mist, Cloud
Cloud amount	1/8	1/8	1/8	1/8
Cloud type	Stratus	Cumulus	Stratus	Stratus
Cloud base	500ft	500ft	500ft	500 ft
Cloud amount	4/8	3/8	3/8	3/8
Cloud type	Stratus	Stratus	Stratus	Stratus
Cloud base	1,000ft	1,000ft	1,000ft	1,000 ft
Cloud amount	5/8	5/8	5/8	5/8
Cloud type	Cumulus	Cumulus	Cumulus	Cumulus
Cloud base	2,000ft	1,500ft	1,500ft	2,500 ft
Temperature	20°C	20°C	20°C	20°C
Dew point	19°C	18°C	19°C	19°C
QNH	1012hPa 29.90inHg	1013hPa 29.91inHg	1012hPa 29.91inHg	1013hPa 29.91inHg

2.6.3 Cloud information charts

According to the cloud information charts for 18:00 and 21:00 on September 27, there was an area of convective clouds including cumulonimbus in the vicinity of a front, which was proceeding north from the bay of Tosa approaching Kochi. The cloud area was expanding while moving north at 6kt, and the altitude of the cloud tops was increasing.

(See Figs. 5 and 6)

2.6.4 Radar Echo Chart (Note 3)

At around the time of 20:25 when the accident occurred, according to the radar echo charts produced by Meteorological Agency weather radar observations at 20:20 there was an echo 16nm southeast of Kochi airport with a diameter of 15km measured at an altitude of 2km, an echo approximately 8nm south-southwest with a diameter of 17km, and both areas contained cumulonimbus with a cloud top altitude of 10–12km. According to the radar observation at 20:30, the echo to the southeast was 15nm distant with a diameter of 15km with cloud tops at 10–12km, while the smaller echo was approximately 6nm south and had a diameter of 17km and with cloud tops at 12–14km.

Each of the two areas of cumulonimbus described above were observed at a number of altitudes (2, 4, 6, 8, 10km) and according to the charts of radar echo strength versus altitude the diameters of the areas were large at all altitudes observed.

Note 3: There are several types of radar echo chart: a 'radar echo strength chart' which shows the strength and position of echoes in a 2.5km mesh at an observed altitude of around 2km and indicates the distribution of precipitation; a 'radar echo altitude chart' which shows the height of the echo in a 25km mesh; and a 'chart of radar echo strength versus altitude' which shows the echo strength at heights of 2, 4, 6, 8, and 10km and position in a 5km mesh. In figures 8 and 9, the 'radar echo strength chart' was observed by weather radar at the Cape of Muroto, and the 'radar echo altitude chart' is a composite of charts from weather radar sites at Osaka, Matsue, Hiroshima, Muroto, Nagoya and Fukuoka.

(See Figs. 8 and 9)

2.7 Communications Information

All communications between the aircraft and Kochi Approach from the time of

the descent until the occurrence of the accident were satisfactory.

2.8 Information on Digital Flight Data Recorder (DFDR) and Cockpit Voice Recorder (CVR)

The aircraft was equipped with a US-manufactured Lockheed Aircraft Service (LAS) model L209 DFDR (Part Number 10077A500-107) and US-manufactured Communication company Cockpit Voice Recorder (CVR)(Part Number 2100-1020-00) which can record the conversation in the cockpit for 2 hours. After notification of the accident was received at 18:28 on September 28th, this was removed from the aircraft. The data's of the CVR were overwritten and erased for over 2 hours. The aircraft continued operations on the day after the accident, and by the time it became clear that the events had been an aircraft accident, the aircraft was operating over 2 hours. Therefore it was clear that the recordings relating to the accident had been overwritten and erased, the device was not removed from the aircraft.

2.8.1 DFDR Recorded Data

All recordings on the DFDR from the time the aircraft began to move from its spot at Tokyo International Airport until it stopped at the spot at Kochi Airport were retrieved.

The relationship between the DFDR recorded time and actual time were determined by collating the VHF transmission key data relating to the aircraft's communications with ATC with the time data on ATC communication recordings. (See Figs. 10-1 and 10-2)

2.9 Medical Information

2.9.1 Injuries to the passengers

The injured persons had been seated in the aircraft's rear cabin. The following summarizes details of the location and extent of injuries of the two passengers who sustained serious injuries (Passengers A and B below) and the one passenger who sustained minor injuries (Passenger C), and their oral statements.

(1) Passenger A, female aged 74 (Seated on seat 40B)

Extent of injuries and Location: Serious injury, fracture of right rib.

Outline of statement: From the start the seat belt wasn't fastened tightly, but was fastened so that you could just about get a

hand through. When the aircraft was shaking, my upper body moved and bent forward right, and my side hit the edge of the armrest of the seat on the right.

(2) Passenger B, female aged 68 (Seated on seat 37E)

Extent of injuries and Location: Serious injury, fracture of right rib.

Outline of statement: My seat belt had been fastened since the start, and was just loose enough to get a hand through. The aircraft made a sudden movement to the right and I thought I was floating. At that time, I heard the sound of my rib breaking, but I endured it and didn't notify the CA right away.

(3) Passenger C, male aged 61 (Seated on seat 41B)

Extent of injuries and Location: Minor injury, bruising of right side.

Outline of statement: The seat belt was always fastened but not so as to be constrictive. I felt as if the aircraft was sinking, and then it swayed sideways. I was thrown towards the aisle side, and my side hit the right armrest.

2.9.2 Confirmation of the passengers injuries

Of the two hundred and eighty eight passengers, including one infant, on board the aircraft, only Passengers A and B sustained serious injuries, and Passenger C was slightly injured. Passenger A was examined by a hospital on the night of the Friday 27 September and was diagnosed with a bone fracture. Passenger B consulted with a travel agent on the afternoon of the Saturday 28 about "what to do about a pain in her chest", and because a medical diagnosis was necessary she went to a hospital on Monday 30 and was diagnosed with a rib fracture. A travel agent telephoned passenger C on Saturday 28 and he informed of an ache when breathing, so he was recommended to go to a hospital. As a result of diagnosis by a hospital on Monday 30, he was diagnosed with bruising.

(See Fig. 3 and Photo. 1)

2.10 Information on Rescue Activities

2.10.1 First Aid by crewmembers and their actions after the accident

The following are outlines of statements of the captain, the first officer, and the cabin attendants regarding the actions and first aid administered to the injured passengers after the accident. In addition, during the flight, the passenger B and C didn't inform to the CA about their injuries.

(1) The Captain

“While we were holding I was asked by a CA whether she could leave her seat to attend to a passenger call, and I gave permission. After that I didn't receive any information from the CA who went to see Passenger A. I heard about passengers who wanted to go to the toilet, but did not confirm the state of injury of Passenger A.

After landing at Kochi and parking the aircraft, I went to the cabin and heard from a CA that Passenger A had hit her right side on an armrest. I did not know at what time Passenger A had been injured. I received a written report from the CP on the handing over to ground staff of the injured Passenger A. The report stated that the shaking occurred at 20:25, but from the cockpit I had felt large changes in G and shaking at 20:27. I had seen no particular changes on the instruments at 20:25.

I later heard from the chief of the passenger service ground staff that Passenger A had sustained bruising and had gone home. I submitted a formal report (INCIDENT /EMERGENCY REPORT) to the Flight Crew Center from the Kochi airport office.”

(2) The first officer

“I was responsible for communicating with CAs, but from when we started our approach, because of the turbulent conditions I entrust the cabin to CAs and concentrated on the flight operations.

While we were holding over Kochi, I received several calls from CAs by interphone on whether they could leave their seats to attend to passenger calls, whether passengers could use the lavatories, and so on.

I also remember a CA reported to me by the interphone that there was a passenger who was holding her Abdomen. I am sure that there was a report sometime during the flight, because I remember that I was reported from a CA by the interphone.

After landing, I received information from a CA that Passenger A had hit her

right side during the time of the large shaking and so she had applied a poultice and handed her over to ground staff.”

- (3) The cabin crew (mainly statements of the CP, supplemented by statements of CA)

“At around 20:34, as I was called by a passenger, I got a permission from the Captain to leave my seat and go to the site of Passenger A at seat 40B, it became clear that she had hit her right side on the right armrest. Because Passenger A’s right side hurt when pressure was applied, the CA stationed at the L2 seat in the left aft cabin handed over three blankets instead of cushions so that her right side would not touch the armrest. Further, the CA offered first aid to Passenger A and then Passenger A watched her condition by herself for a while.

The CA then returned to the L2 seat, and she reported to the cockpit on the interphone that she had returned to her seat, Passenger A had hit her side painfully on the armrest, and that she had been given blankets to stop her side hurting when hitting the armrest during the continuing shaking. The CP was monitoring this report while watching the situation, because the CA reports to the Captain surely when she returned to her seat, after she got a permission to leave her seat.

Ten minutes later the CA stationed at the L2 seat went to check the condition of Passenger A, but could see nothing abnormal such as redness or swelling on the affected part. Since Passenger A was elderly the CA suggested making arrangements for a hospital visit just in case, but Passenger A refused.

On disembarkation at Kochi Airport, the condition of Passenger A was reported to passenger service ground staffs, who were asked to arrange for hospitalization if necessary. Further, Passenger A was given a poultice. ”

2.10.2 Actions by ANA ground staff

The following is a summary of the actions of All Nippon Airways ground staff at Kochi Airport drawn from the statements of the passenger service staff and chief of passenger service staff at the ANA’s sole agency office at Kochi Airport.

- (1) The passenger service ground staff had heard from station control (managing departures and arrivals) that the aircraft had encountered

severe turbulence during the approach, and so after the aircraft had arrived they stood by at the door side watching the disembarking passengers with a wheelchair ready in case any passengers were feeling unwell.

When Passenger A disembarked last, holding her right side, the attending ground staff took her over from a CA and asked about her condition. The ground staff recommended that Passenger A use the wheel chair and go to hospital for an examination, but Passenger A refused.

The attending ground staff then guided Passenger A to the first floor arrival lobby and handed her over to the chief passenger service ground staff.

- (2) The chief of the passenger service ground staff again recommended to Passenger A that she goes to the hospital, but Passenger A refused saying that she was not carrying her health insurance document and was tired and wanted to go home. The chief of passenger service ground staff then informed Passenger A that she would telephone her at around noon the following day to ask her condition. After that, at around 21:55, the handling of Passenger A was reported to the Captain and CP.

At around 09:40 on the following day (28 September), a telephone call was received from the travel agent notifying that Passenger A had consulted a hospital late at night on 27 September and had been diagnosed with a bone fracture.

On the afternoon of the 28th, the ANA Company checked the condition of Passenger A and confirmed that she had sustained a bone fracture.

2.11 Other Relevant Information

2.11.1 Flight Planning and Briefing

The following is a summary of the statements of the dispatcher who issued the flight plan at Haneda Airport and the assistant dispatcher who briefed the Captain on the day of the accident.

- (1) The dispatcher

“Bad weather conditions were expected due to a stationary front off the coast

south of Kochi Airport which was being energized by Typhoon 21. There wasn't so much in the morning, but after noon the echoes gradually moved north, and since I thought that missed approaches or holding might be expected, I added one hour extra fuel.”

(2) The assistant dispatcher

“Other flights were reporting ‘light’ turbulence in clouds en-route. The flight had been planned with high-speed cruise since it would be nearing the end of the operating hours of Kochi Airport (until 20:30).

The Captain had checked the weather conditions himself before the briefing.

I briefed the Captain mainly concentrating on en-route. Although the dispatcher had proposed FL240, the Captain made in FL260 because the first officer, who was joining the flight after a flight from Takamatsu, had experienced ‘light minus’ turbulence at FL240. Although there were weak rather than active echoes around the destination of Kochi, when previous data was viewed in time sequence it did not appear that the echoes would directly cover Kochi Airport. Moreover, during the pre-checking stage the information from the Kochi assistant dispatcher indicated no heavy turbulence during the descent. Further, I briefed the Captain that a precision approach was available under current wind conditions and that there were no particular operational matters.

For the briefing I used the 18:00 weather information and the 15:00 aerodrome forecast weather report. Also, I gave the information package [an information package comprising weight and balance data, aviation routine weather reports, aerodrome forecast weather report and flight information] to the Captain.

While I briefed that it a one-hour extension of the aerodrome’s operations was possible, however the Captain pointed out about the one hour of extra fuel, it was too much by 30 minutes because of the aerodrome’s operating hours.”

2.11.2 Extension of the operational hour

The following is a summary based on the statements of the Captain and the first officer.

The aircraft blocked out (started to taxi) at 18:59, but because of ATC delays it took some time until take off. While taxiing at Haneda airport, the Captain used the company radio to request the assistant dispatcher in charge of air communications at Haneda Airport to co-ordinate for an extension to the Kochi airport operating

time because if the aircraft did not take off before 19:25 it would not make Kochi Airport before the close of operations (20:30).

During the climb the assistant dispatcher in charge of air communications at Haneda Airport contacted the aircraft and informed that the operating hours extension was possible.

2.11.3 The 'OPERATIONS MANUAL (SUPPLEMENT)' of All Nippon Airways contains the following descriptions regarding the prevention of injuries in the cabin due to turbulence. (part of the following extract and the 'Turbulence Strength Criteria' described in are in an Attachment).

7. Turbulence Information

While it is difficult to forecast turbulence accurately, weather information should be positively grasped and provided, and the following considerations should be applied.

Measures to be taken by ground operations personnel

Ground operations personnel should actively collect radar weather charts, forecasts, area meteorological advisories, air route weather information, pilot reports, etc. regarding the weather conditions on the aircraft's planned route, and conduct the preflight briefing appropriately. Moreover, if turbulence information is received it should be provided to aircraft in flight as necessary.

Measures to be taken by Captains

Before flight, Captains should hold an adequate briefing with ground operations personnel as necessary based on information provided. Further, turbulence encountered during flight should be actively reported via company radio and appropriate de-briefing should be carried out after the flight.

Common understanding of turbulence information

In order to plan suitable measures to deal with turbulence, it is useful to have a common understanding of turbulence strength among persons connected with operations. The "Turbulence Strength Criteria" used by all domestic aircraft operators are indicated below, and should be referenced.

2.11.4 All Nippon Airways' Operation Control Center (OCC) issues 'Weather Briefing Reports' to all ground operations personnel (dispatchers, assistant

dispatchers) in Japan at least four times a day.

The 15:00 No. 03 report on the day of the accident (effective 18:00–24:00), referring to the western Japan area, contained upper air weather forecast and advisories that should be noted when preparing operational flight plans. Among these was the advisory description of “Caution is advised for turbulence and low-level windshear in thunderstorms and active cells (confirm with latest radar echo charts)’.

2.11.5 Cabin announcements

Chapter 7 of All Nippon Airways’ cabin crew operating manual, “Cabin Announcements”, contains the following sample announcements for ‘at illumination of seat belt signs’ and ‘before landing’.

At illumination of seat belt signs:

We (are/will be) passing through an area of (slight/severe) turbulence.

Cabin attendants are also required to be seated.

Please make your seat belt is securely fastened.

Please refrain from using lavatory (Telephone), and please put your hand baggage under the seat in front of you. (Passenger using personal television sets should return them to the original position.)

* If cabin safety check cannot be made prior to landing, the following pre-landing announcements should be made in addition to above.

Before landing:

Ladies and gentlemen, (We are now landing)

(We are now making our final approach.)

On no smoking flight:

Please fasten your seat belt securely.

On smoking flight:

Please fasten your seat belt. (Please confirm your seat belt fastened.), and refrain from smoking.

2.11.6 The following description is contained in ‘Chapter IV Radar Operating Procedures, 15 ADDITIONAL SERVICES (note 4)’ of the Air Traffic Control regulations manual ‘Air Traffic Control Procedures’ (Kusei No.5, effective from January 9, 1965). In the following, ‘chaff’ refers to radar reflecting flakes which aircraft targeted by missiles scatter in large volumes to disturb radar waves.

(Radar weather information and Chaff information)

(6) a: Information on the position of areas of hazardous weather or chaff observed on the scope should be reported with the direction and distance from an aircraft, fix or aerodrome (in the case of an aircraft, using the 'clock' direction), and guidance for avoidance should be provided to aircraft that request it.

Note 4: ADDITIONAL SERVICES conducts advisory information provided by ATC on a workload-permitting basis, which includes but is not limited to the following.

- 1) Traffic advisories, including radar traffic information.
- 2) Weather and chaff information.
- 3) Bird activity information.

3. ANALYSIS

3.1 Analysis

3.1.1 The Captain and First Officer had valid airman proficiency certificates and valid aviation medical certificates in accordance with applicable regulations.

3.1.2 The aircraft had a valid certificate of airworthiness and had been maintained their maintenance and inspection in accordance with applicable regulations.

3.1.3 Weather conditions at around Kochi Airport and the occurrence of the accident

A low-pressure area was progressing and approaching toward Kochi Prefecture. It is considered that the area surrounding of the progressing low-pressure area becomes enveloped by nimbostratus, and active cumulus clouds then generates cumulonimbus.

The aircraft's DFDR recordings indicate that a fall by a rise in air temperature followed occurred several times during the approach to Kochi Airport. It is considered that the aircraft was flying through the top of a layer of cold air over the surface.

The aircraft's altitude dropped by around 100ft between 20:25:02 and 20:25:03. The winds experienced by the aircraft around that time were: 20kt from the south at 20:24:59, 33kt from south-southeast at 20:25:03, 14kt from the south at 20:25:07

and 15kt from south-southwest at 20:25:11. It is therefore estimated that during this period of time, the wind direction was fluctuating between south-southwest and south-southeast, and the wind speed was changing abruptly between 14kt and 33kt. From these facts, it is considered that the aircraft was shaken violently around 16nm from the runway of Kochi Airport due to flying through a place of high wind shear near a cumulonimbus which had developed to a large size as described in 2.6.4.

It is estimated that as a result of this, an accident occurred and passengers sustained serious injuries as described in section 3.1.7.

3.1.4 The operation of the aircraft's weather radar and requests for ground radar information

- (1) The operation of the on-board weather radar and weather condition at around the aircraft encountered the accident.

The flight crew stated that during the final approach to Kochi Airport, including the period until 20:25 when the accident occurred, they were flying to avoid echoes displayed on the on-board weather radar. At that time, the aircraft was descending from around 6,000ft. Because approx.3° wide beam of the aircraft's weather radar would be reflected from the sea or ground surface if it were directed downwards, it is estimated that the beam was directed 4°-5° above the horizon and was detecting echoes in front of the aircraft scanning once every four seconds.

According to the on-board weather radar indication, the area at around 2,600ft altitude the aircraft encountered rapid violent movement, although there was no echo area other than some echoes nearby. However, at the point where the aircraft encountered the violent movement, it is estimated that they were flying in an air current with accompanying rapid changes in wind.

It is also estimated that in the area of rapid changes in wind accompanying cumulonimbus clouds, even though the onboard weather radar search in this direction, the radar cannot detect any echo in the place with a little rain.

- (2) Characteristics of the Weather Bureau's radar and the on-board weather radar Comparing the Weather Bureau's radar echo strength charts in section 2.6.4 with the aircraft's position from the DFDR recordings, it is thought that at the time of the accident around the final approach course, there was a strong, large-scale echo with high altitude cloud tops. Generally, it is

considered that violent air currents exist in and around large scale, high cloud top altitude echoes containing localized areas of high reflection strength.

When compared to the on-board weather radar, the Weather Bureau radar echo strength charts have a rather coarse mesh, observation rate is once every ten minutes compared to the near real-time on-board weather radar display. It is therefore considered that on-board weather radar displays echo distribution more accurately at any given time than Weather Bureau radar echo strength charts. On the other hand, on-board weather radar has narrow radiation beams. If the on-board weather radar with fixed antenna direction is used, it indicates only limited environment information. Therefore, in the case of this accident, it is thought possible that the on-board weather radar could not detect echoes because of the antenna direction, however the echoes on the course positioned South-East of Kochi Airport were detected by the Weather Bureau radar widely echo strength charts at an altitude of about 2km made with the Cape Muroto radar. (See Fig.8 and 9)

(3) Request information to the Ground

Although the flight crew could not directly see the Weather Bureau radar echo strength charts in the case of this accident, the Kochi assistant dispatcher had received the radar echo information chart which synthesized the Weather Bureau radar echo strength charts and radar echo top altitude chart (as attached Fig.7-2) several minutes later than the observed time. The forementioned assistant dispatcher had adequately provided the information about the echo situation around the final approach course to the aircraft's flight crew. It is considered that the Captain should have considered the weather conditions along the flight course including this echo information.

It is considered that the Captain continued the approach at that time because there were no severe echoes on the flight path shown on the aircraft's weather radar, and that although turbulence was forecasted, the aircraft had already started on its final approach course. However, given that the weather in the vicinity of Kochi Airport was bad, and there were active echoes scattered around the flight course, it was desirable for the Captain to have properly confirmed the echo's position, size, direction of movement, speed of movement, and so on by contacting the ground facility. As described in section 2.11.6, it was also desirable that the captain asked the weather condition on the approach course to the ATC facility in addition to the echo information

from on-board weather radar. Then, considering all weather information from the ground facility and on-board systems collectively, the pilot could have established more clearance from the echoes as far as possible.

(4) Providing echo information from ground facility

Regarding the provision of weather information from the ground to the aircraft on the approach to Kochi Airport, the Kochi assistant dispatcher stated that he reported that there were echoes around 10nm southwest and around 10nm southeast of the airport and that these were proceeding slowly north. However, the flight crew stated that they recognized from the Kochi assistant dispatcher's information that there were echoes directly over Kochi Airport and 30nm east of the airport and that these were moving relatively quickly northwards.

It is considered that the differences in these statements about echo information might have arisen due to information not being communicated adequately.

3.1.5 The Briefing at Haneda Airport

According to section 2.11.1, the Haneda dispatcher stated regarding the flight that he had prepared the flight plan to include extra fuel for an additional hour of flying time. This extra fuel was manifested in anticipation that it might be necessary to hold over Kochi Airport until bad weather would pass.

However, it is considered that for the Captain's briefing, the assistant dispatcher at Haneda responsible for the briefing briefed mainly on the en-route conditions, as there were areas along the flight route in which turbulence was expected, and without considering the deterioration of the weather around Kochi airport, did not brief on these matters.

Further, as described in section 2.11.4, if the assistant dispatcher at Haneda in charge of the briefing had considered that an advisory had been issued that "Caution is advised for turbulence and low-level windshear in thunderstorms and active cells (confirm with latest radar echo charts)", it is thought that he should have taken sufficient notice of the tendency for the weather to deteriorate due to the effect of the front in the vicinity of Kochi, conducted an sufficient analysis, and should have explained to the Captain the weather deterioration including the reason for the necessity of the one hour extra fuel.

3.1.6 The assistance from the Kochi assistant dispatcher

According to 2.11.3, it is generally considered that assistant dispatchers, including the Kochi assistant dispatcher, should actively collect data on weather conditions along the planned flight route and provides this information to aircraft in flight as necessary.

The Kochi assistant dispatcher received a telephone request from the Haneda dispatcher responsible for communication with the aircraft during cruises to advice the Captain about the echo information. After received this request, the Kochi assistant dispatcher provided the 20:00 radar echo observation information in his first communication with the aircraft, but it is considered that he did not subsequently provide information to the aircraft during the approximately 17 minute period until the time the aircraft encountered the accident and made its missed approach.

An airport weather information report regarding thunderstorms relating to Kochi airport was issued at 18:05 (effective from 18:05 on September 27 until 03:00 on September 28). The report contained cautions that during the period of its validity, a low pressure would approach the vicinity of Kochi Airport and atmospheric conditions would be unstable, and that Kochi airport might experience lightning strikes, sudden gusts, turbulence, short periods of heavy rain, intermittent poor visibility and intermittent low ceiling. If the Kochi airport assistant dispatcher had considered that the weather would deteriorate from the south, where the aircraft's approach course was located, he should have paid sufficient attention to the change in the weather and to compare with radar echo information chart observed at 20:00, and then he had to make good use of radar echo information chart at 20:10 which was the worse condition observed, he should have actively provided support from the ground by providing information on the position, size, strength, height, direction and speed of movement etc. of the echoes around the final approach course. In particular, it is considered that in the event that echoes are located along the flight route of an aircraft that is being supported by operational assistance, such information should certainly be transmitted.

(See Figs.7-1 and 7-2)

3.1.7 Analysis of the aircraft movement and the conditions in which injuries occurred

According to the DFDR recordings, it is estimated that the aircraft was flying with the autopilot ON at the time of the accident.

- (1) The following is the result of the analysis of DFDR recordings relating to the aircraft movement. The descriptions of directions of acceleration (up, down, right and left) relate to the direction of motion of the aircraft.

From 20:24:23 to 20:25:52, it is estimated that the aircraft was flying along the localizer course.

Between 20:25:02 and 20:25:05, the aircraft was approximately 16nm from the runway of Kochi Airport descending at an altitude of around 2,600ft. In the one-second interval from 20:25:02 to 20:25:03 it abruptly descended 100ft. At 20:25:03, it is estimated that the aircraft's roll angle was 8.1° right and it was experiencing a lateral acceleration of 0.4G left and a vertical acceleration of 1.6G upward. One second later, at 20:25:04, the aircraft's roll angle was 9.7° left, lateral acceleration was 0.1G right and vertical acceleration was 0.6G downward.

During this period, it is estimated that the aircraft was at its closest proximity to the lower layer of an active cumulonimbus and experienced windshear and sideways force.

- (2) At the time of the accident, DFDR data indicates a peak left sideways acceleration of 0.4G and a peak right sideways acceleration of 0.1G. However, from the result of a study that analyzed the accelerations, it is possible that seats 37E and 40B in aft cabin, which were occupied by the Passengers A and B who sustained serious injuries, experienced greater changes in left and right side (lateral) acceleration than the values recorded by the DFDR.

The accelerometers were installed near the aircraft's center of the gravity.

- (3) From the above, it is estimated that the aircraft abruptly descended around 100ft at 20:25:02, and immediately afterward at 20:25:03, when the aircraft was banked to the right, the upper bodies of the passengers leaned to the right together with the aircraft's attitude, and the sideways motion of the upper bodies of the three passengers whose seatbelt were loosely fastened was increasing towards the right. In the next instant, when the aircraft banked to the left, the right sides of their upper bodies that were inclined towards the right struck the armrests, and it is estimated that Passengers A and B fractured their ribs sustaining serious injuries, and Passenger C sustained bruising and was slightly injured as a result.

From section 2.9.1, it is estimated that the seatbelts of the three injured Passengers A and B who sustained serious injuries did not like pressure on their abdomen, their seatbelts were fastened sufficiently loosely as to be able to insert a hand. It is further estimated that the seatbelt of Passenger C, who sustained minor injuries, was not fastened tightly.

3.1.8 Cabin announcements, etc. during the approach to Kochi Airport

- (1) The cabin announcement from the Captain and turned on the seatbelt signs

At around Kushimoto the Captain announced to the passengers that because turbulence was expected during the descent, the passengers should finish using the lavatory early, and just before starting the approach to Kochi Airport at around 20:20, he instructed the First Officer to tell the cabin attendants to be seated and to make advisory cabin announcements instead of conducting the cabin safety check. Since the Captain had turned on the seatbelt signs, it is considered that all persons on board the aircraft had fastened their seatbelts.

- (2) Cabin announcement, etc. by the Chief Purser

Based on the sample announcements described in 2.11.5, it is considered that at ten minutes before landing the Chief Purser had made the cabin announcements for 'at the illumination of seatbelt signs' and 'before landing'.

Although the injured Passengers A, B and C had been prepared for sudden turbulence even when the seatbelt signs were switched off, since their seatbelts had been fastened since take off, the seatbelts of Passengers A and B were loose to the extent of being able to insert a hand, and the seatbelt of Passenger C, who sustained slight injuries, was not tightly fastened. It is estimated their seatbelts remained loose even after the Chief Purser's cabin announcement.

Since it is thought if seatbelts are loose when turbulence is expected during flight it is because their effectiveness has not been adequately demonstrated, it is considered that a cabin announcement was made to confirm that seatbelts were securely fastened and not twisted.

It is considered that even after Passenger A in seat 40B had reported that she had hit her right side on the armrest when the aircraft moved sideways, Passenger B in seat 37E had sustained injuries in a similar manner but was enduring the pain. There was no experience to get damages on passengers who had their seatbelts fastened. It is believed that the CP didn't have any

recognition about any injured persons other than passenger A at that time. But, the extent of Passenger A's injuries could not be ascertained by external appearance, which was just thought to be bruising, it is considered desirable that the Chief Purser should have made a cabin announcement requesting that any injured passengers identify themselves.

3.1.9 The reporting of the state of the injured from the aircraft to the ground

According to 2.10.1 (3), although a cabin attendant reported to the cockpit that a passenger was in pain due to hitting her armrest, according to the Captain, this was not notified to the Captain, and further, the Captain stated that he had not recognized any reports from the cabin attendants.

Moreover, the First Officer stated that he remembered hearing the report during the sometime in the flight, but he was absorbed in flight tasks because of the bad turbulent conditions during the approach and he had left the cabin attendants to handle the cabin. While holding over Kochi, it is conceivable that the First Officer should report to the captain when the First Officer got a report about the injury of the passenger from CA.

Further, the Kochi assistant dispatcher stated that while he had received a report of the situation of the aircraft movement by turbulence while the aircraft was in flight, there had been no word regarding the condition of passengers or the cabin.

From the above, it is estimated that there was no report from the aircraft to the ground during the flight regarding passengers' injuries.

3.1.10 Communication of information

As described in the following, it is considered possible that regarding this accident, communications of information between the flight crew, CA, the Haneda dispatcher and assistant dispatcher in charge of the briefing, and the Kochi assistant dispatcher were not conducted appropriately.

- (1) The Haneda dispatcher had anticipated deterioration in the weather at Kochi Airport and had added one hour of extra fuel. However, the Haneda dispatcher responsible for the briefing did not communicate to the Captain that the reason for the extra fuel was because of the forecast deterioration in the weather at Kochi Airport.
- (2) Although the Kochi assistant dispatcher was requested by the Haneda dispatcher responsible for communicating with the aircraft during its cruise to

advise the aircraft on echo information, because he did not sufficiently understand its necessity, he did not provide adequate echo information to the aircraft.

- (3) There were differences between the echo information received from the Kochi assistant dispatcher and the echo information, which the Captain and the First Officer obtained from the on-board weather radar during final approach.
- (4) After the accident had occurred, the Captain did not confirm the report of CA's returning her seat and the status of injured person to the cabin attendants. Moreover, although the First Officer had heard about the state of the injured Passenger A from a cabin attendant, he did not report to the Captain.

From the above, it is considered that information was not communicated accurately, and it is possible that operations continued with doubts not being resolved. It is also considered when doubts or anxieties arose regarding received information, it was necessary to confirm them accurately. Since the positive and appropriate communication of information is considered effective for securing flight safety and the proper treatment of the injured if an accident occurs, it is considered necessary to further promote co-operation between personnel concerned, beginning with crews.

4. PROBABLE CAUSE

In this accident, it is estimated, during final approach, the aircraft encountered air currents accompanying rapidly changing winds when it passed close to a active cumulonimbus, because of this, the aircraft experienced violent lateral motions, and as a result two passengers sustained serious injuries.

Figure 1 Presumed flight route

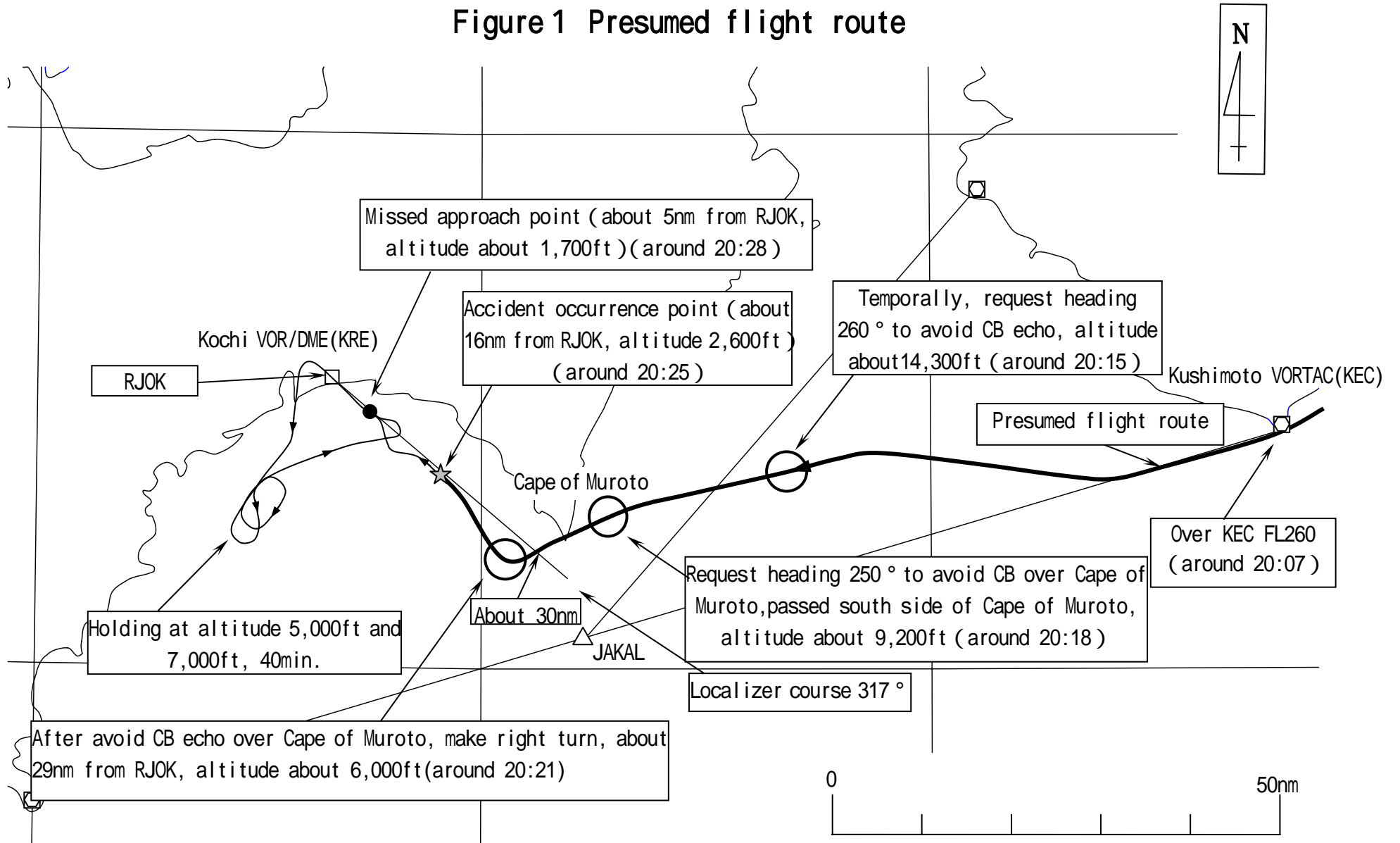

Figure 2 Three angle view of BOEING 767-300

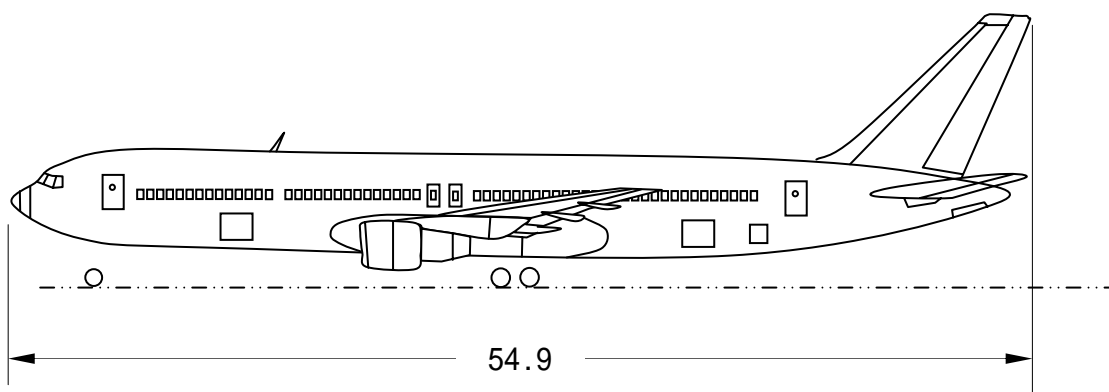
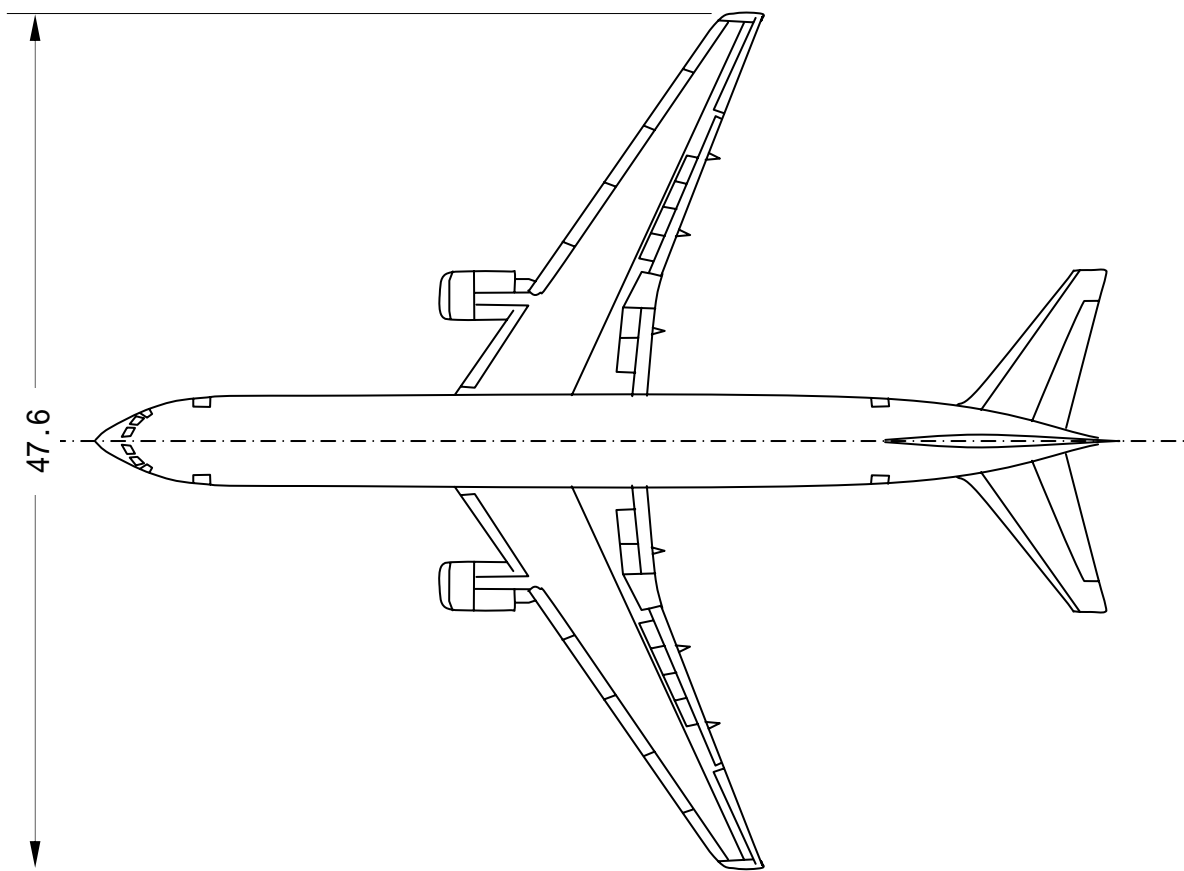
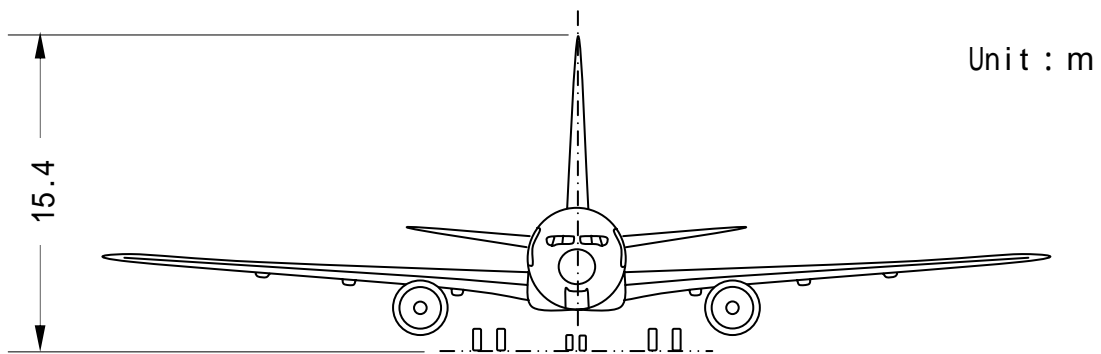

Figure 3 Injuries layout

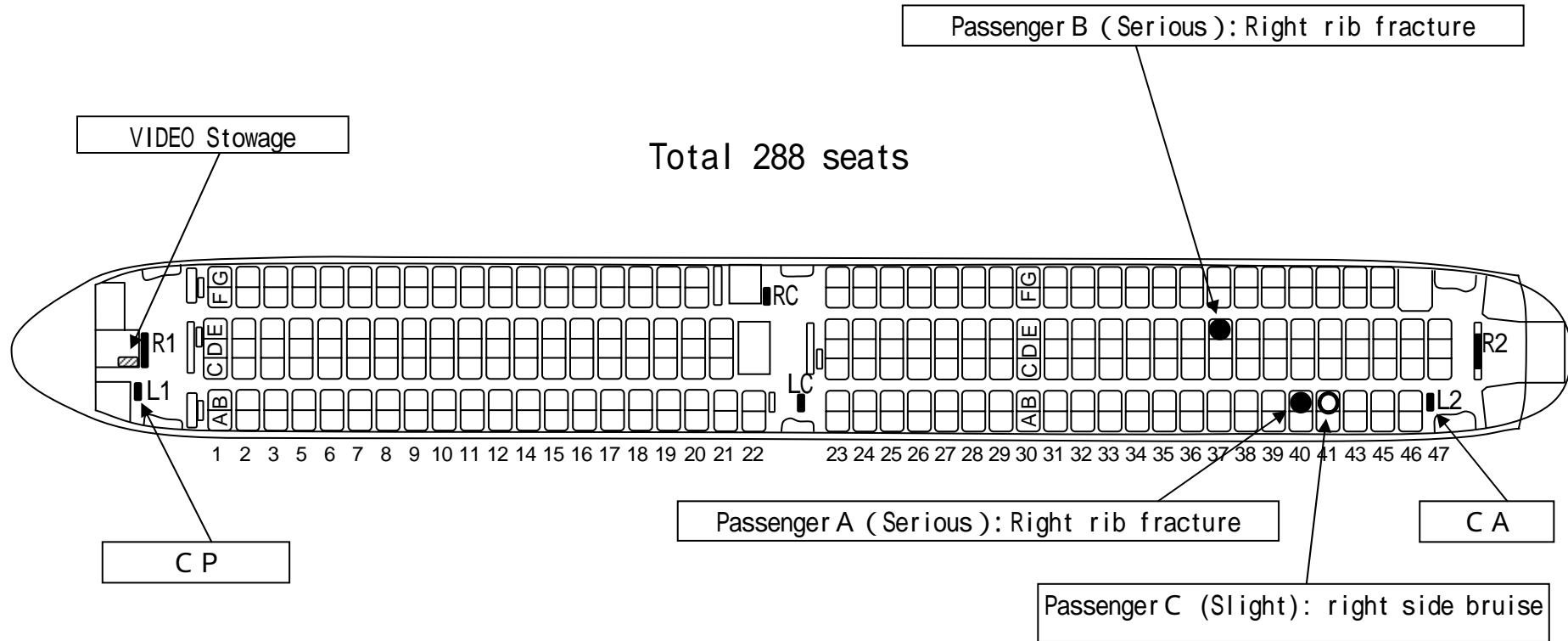

Figure 4 Asian Surface Analysis Chart (September 27, 21:00JST)

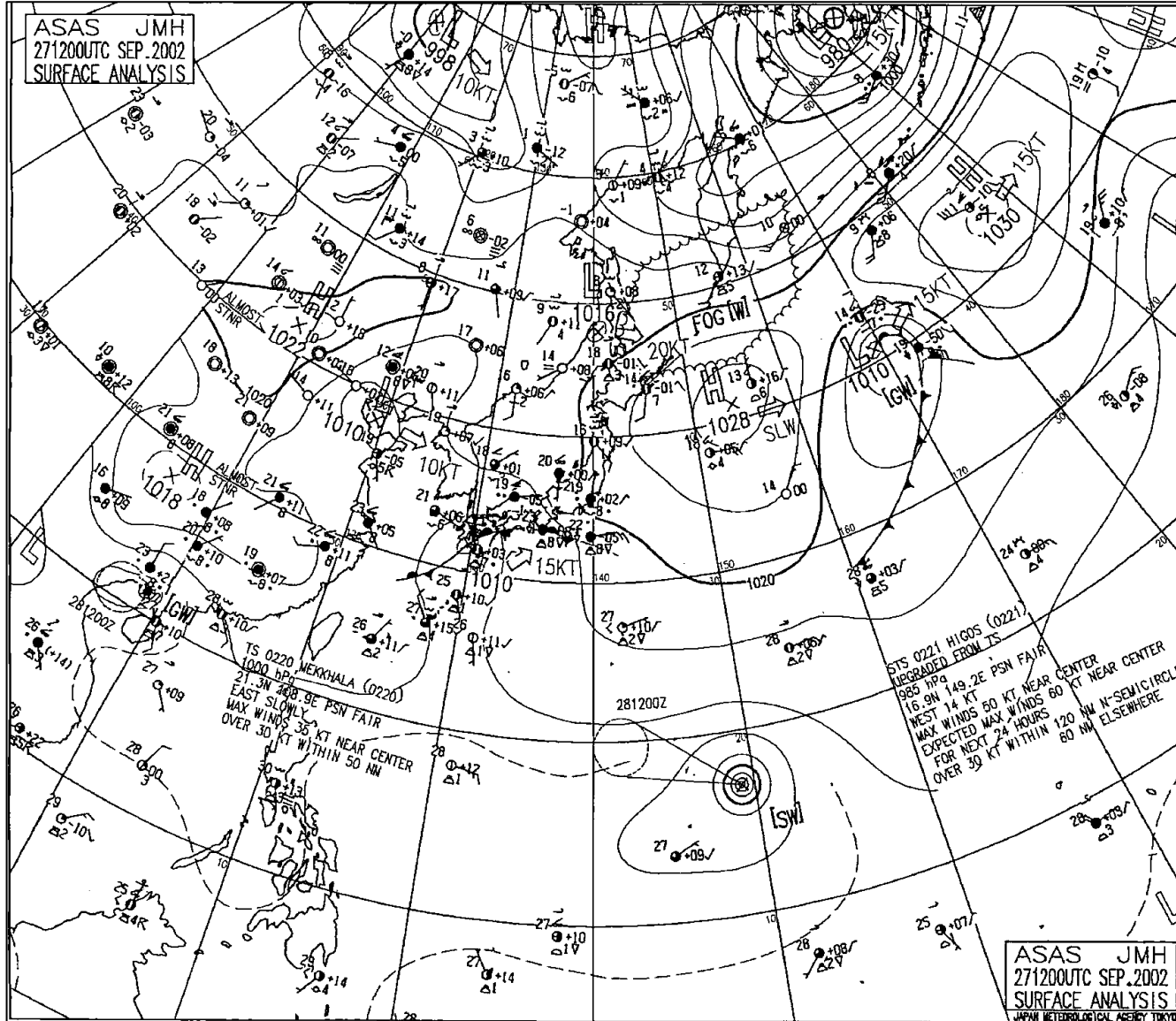

Figure 5 Cloud Information Chart (September 27, 18:00JST)

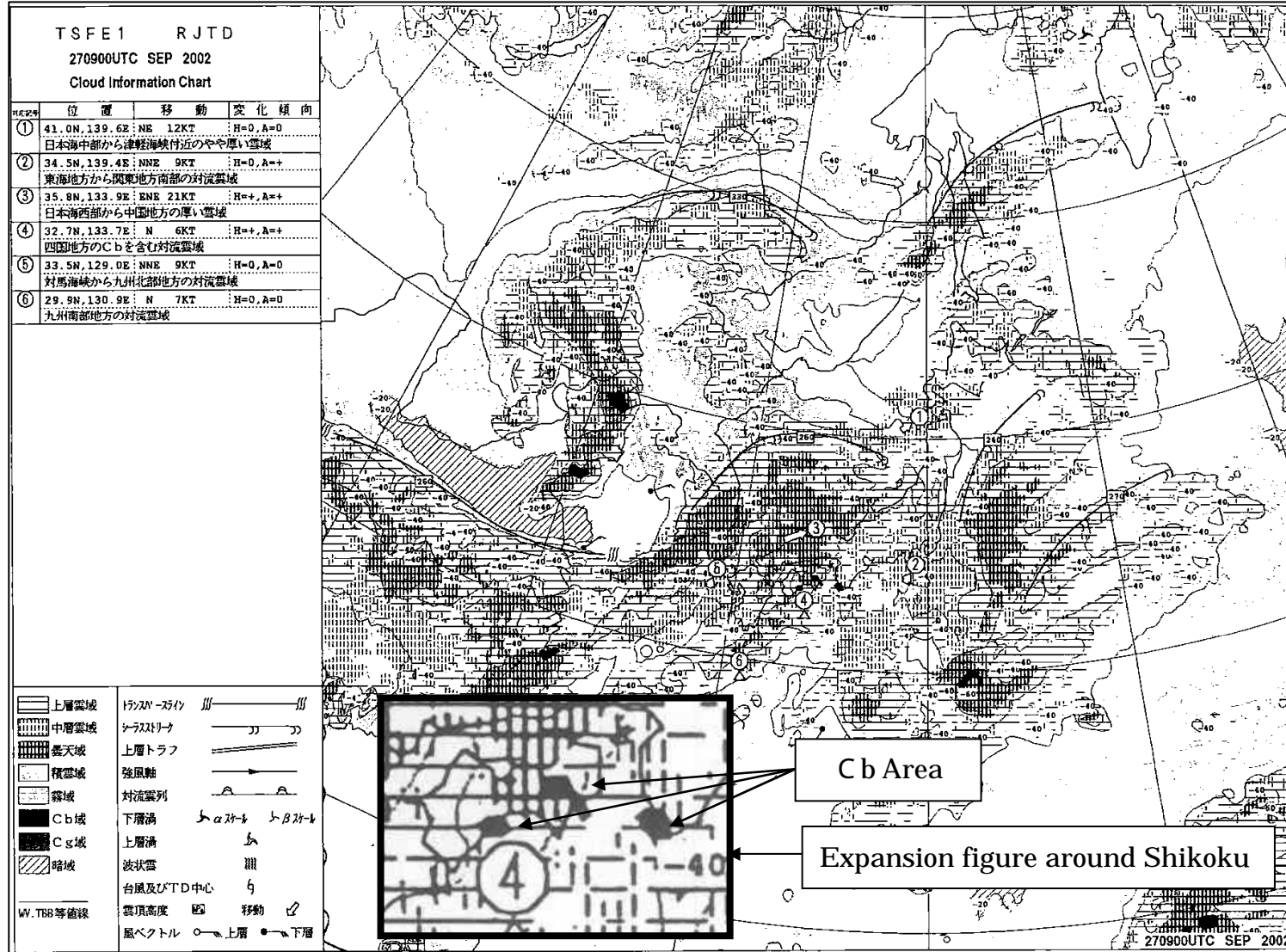

Figure 6 Cloud Information Chart (September 27, 21: 00JST)

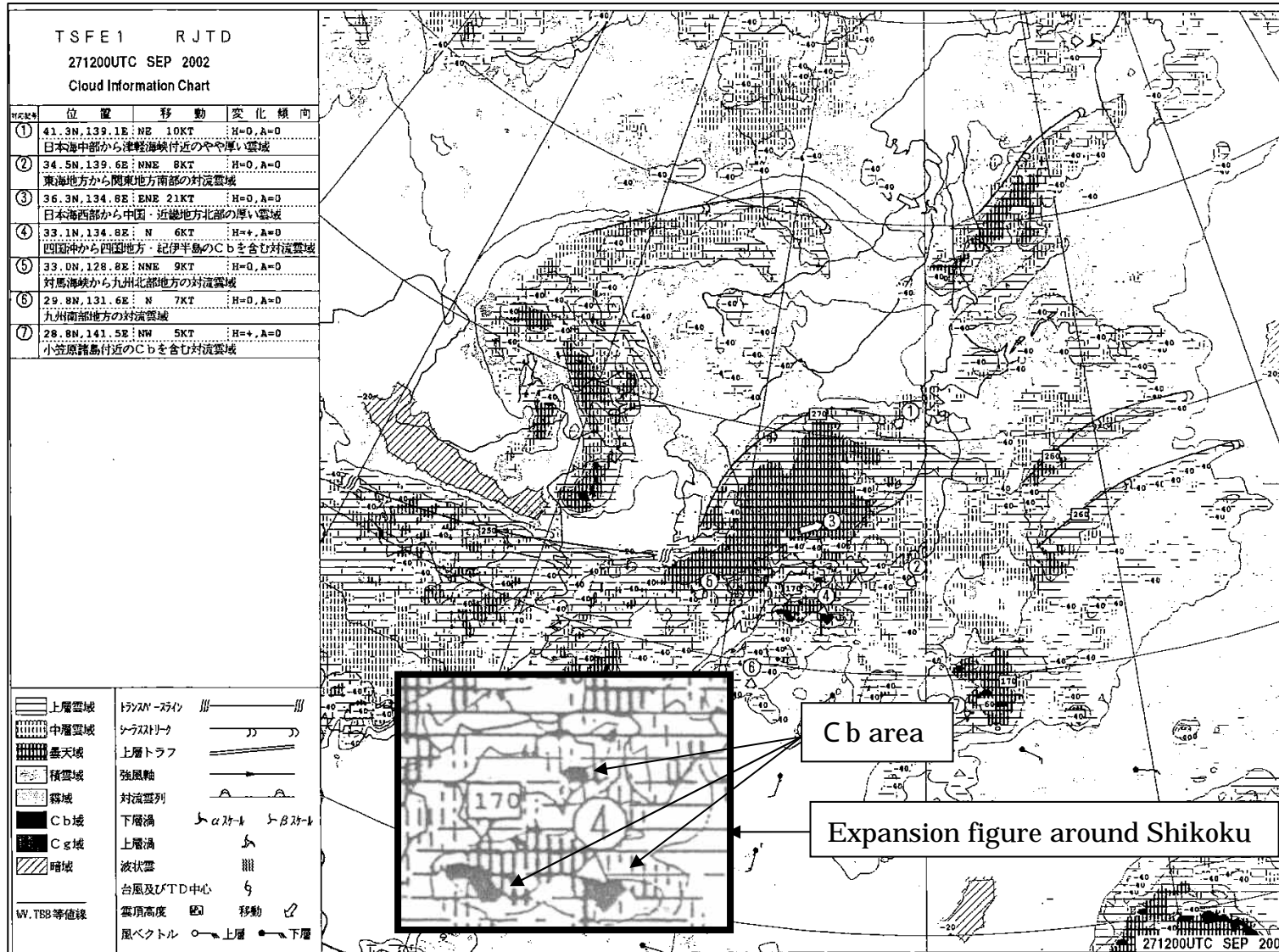
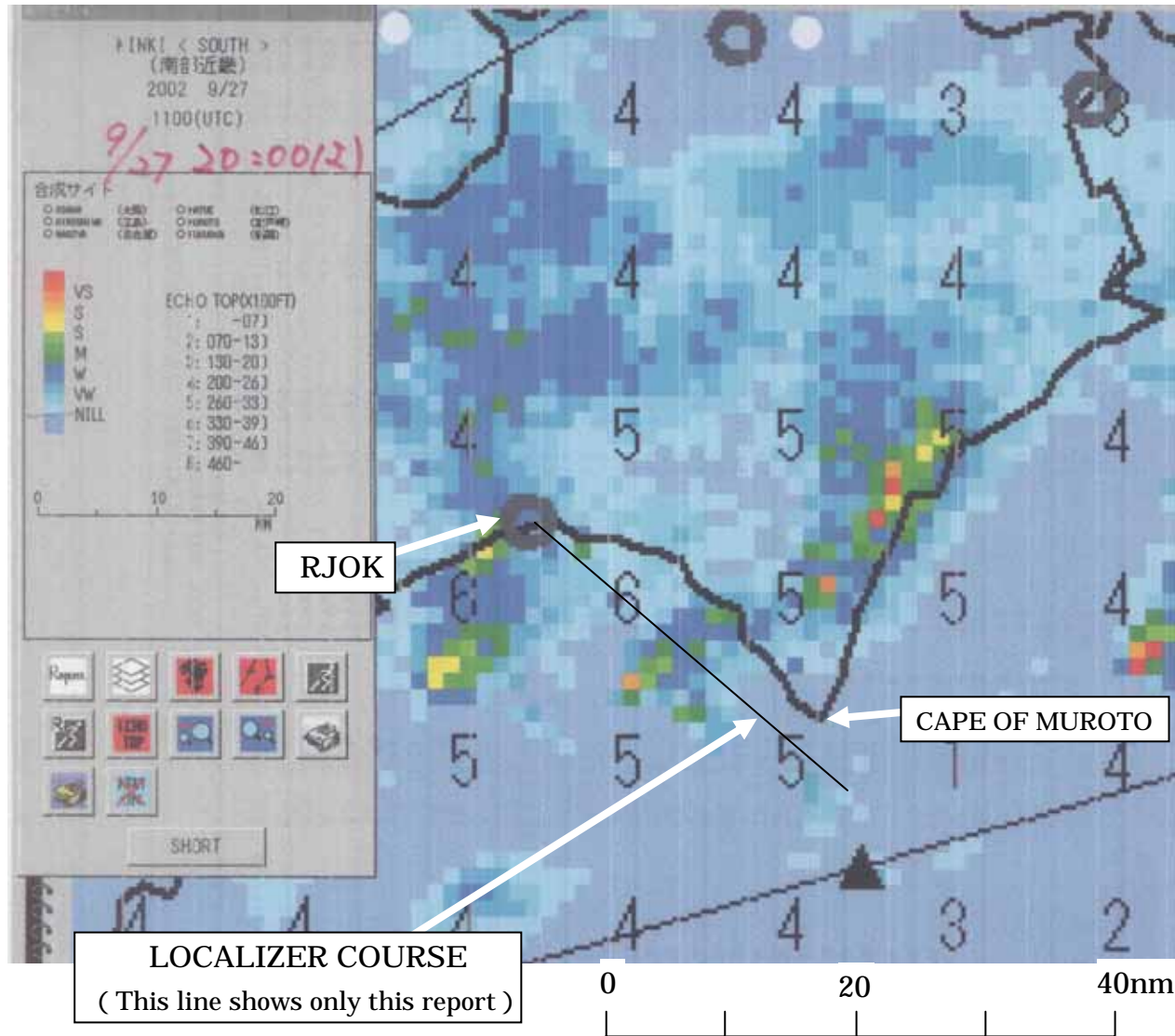

Figure 7 - 1 Radar Echo Information chart

which was used by Assistant Flight Dispatcher of RJOK (September 27, 20:00JST)



ANA's radar echo information chart is synthesized radar echo chart and radar echo summit altitude chart.

The number shows echo summit altitude.

ECHO TOP (X100FT)

- 1: -070
- 2: 070-130
- 3: 130-200
- 4: 200-260
- 5: 260-330
- 6: 330-390
- 7: 390-460
- 8: 460-

Echo strength is displaying the precipitation strength (the mm/hr) that converted into precipitation of one hour with the scale (color).

- VS Very Strong
- S Strong
- M Moderate
- W Weak
- VW Very Weak

Figure 7 - 2 Radar Echo Information chart showing a tendency to bad weather which was not reported to the aircraft by Assistant Flight Dispatcher of RJOK (September 27, 20:10JST)

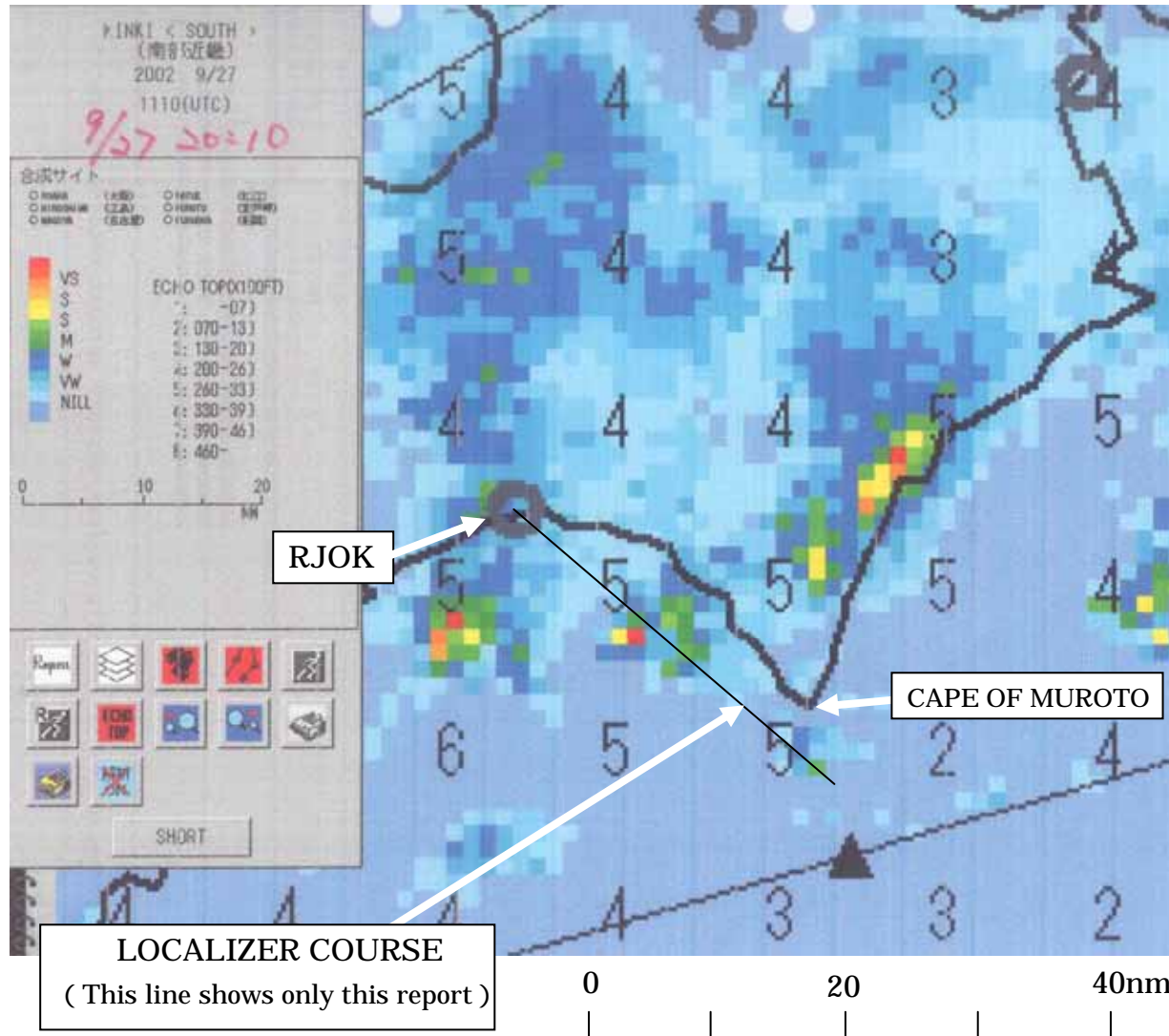

ANA's radar echo information chart is synthesized radar echo chart and radar echo summit altitude chart.

The number shows echo summit altitude..

ECHO TOP (X100FT)

1: -07
2: 070-130
3: 130-200
4: 200-260
5: 260-330
6: 330-390
7: 390-460
8: 460-

Echo strength is displaying the precipitation strength (the mm/hr) that converted into precipitation of one hour with the scale (color).

VS Very Strong
S Strong
M Moderate
W Weak
VW Very Weak

Figure 8 Radar Echo Chart (September 27, 20:20JST)

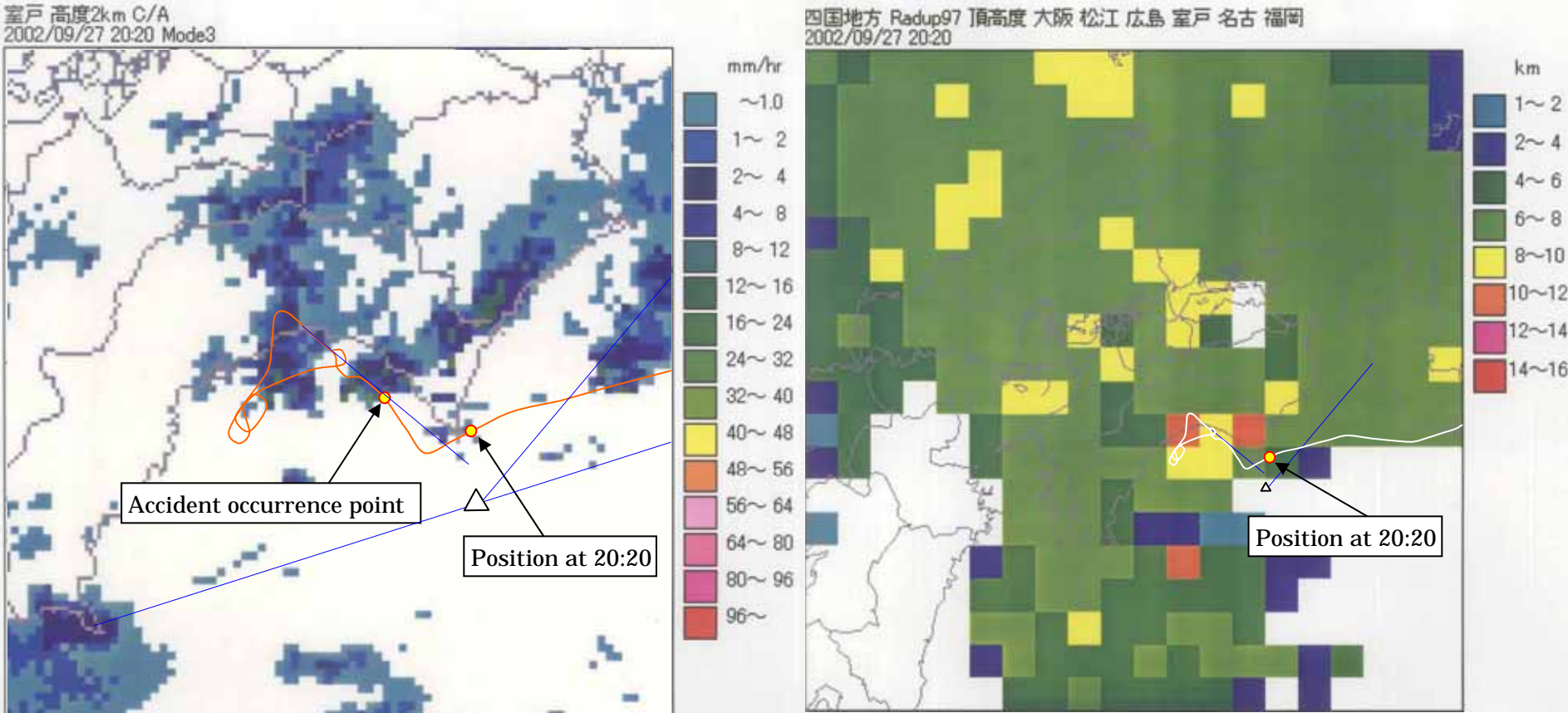

Radar echo strength chart (mm/hr)

Radar echo summit altitude chart (km)

Figure 9 Radar Echo Chart (September 27, 20:30JST)

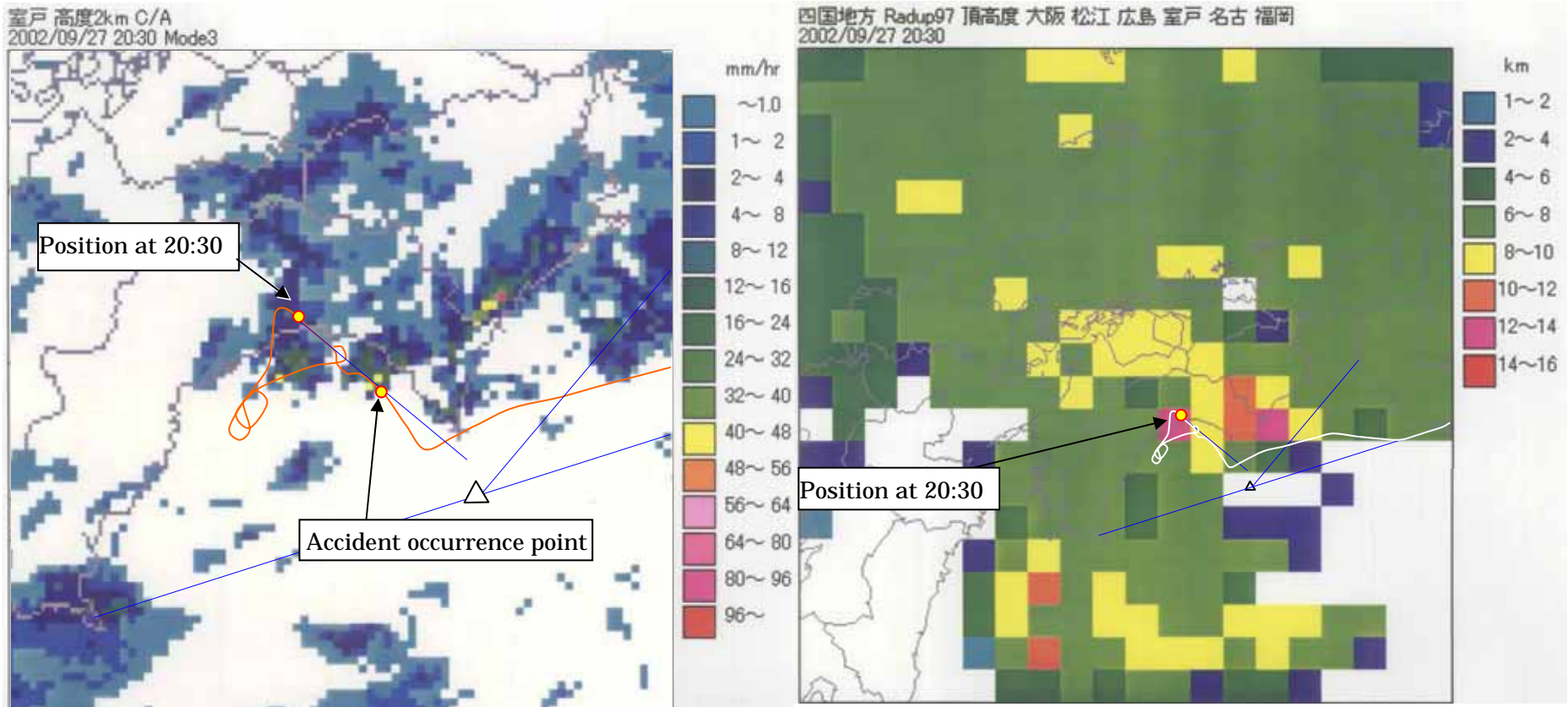

Radar echo strength chart (mm/hr)

Radar echo summit altitude chart (km)

Figure10-1 DFDR Recorded Data (1)

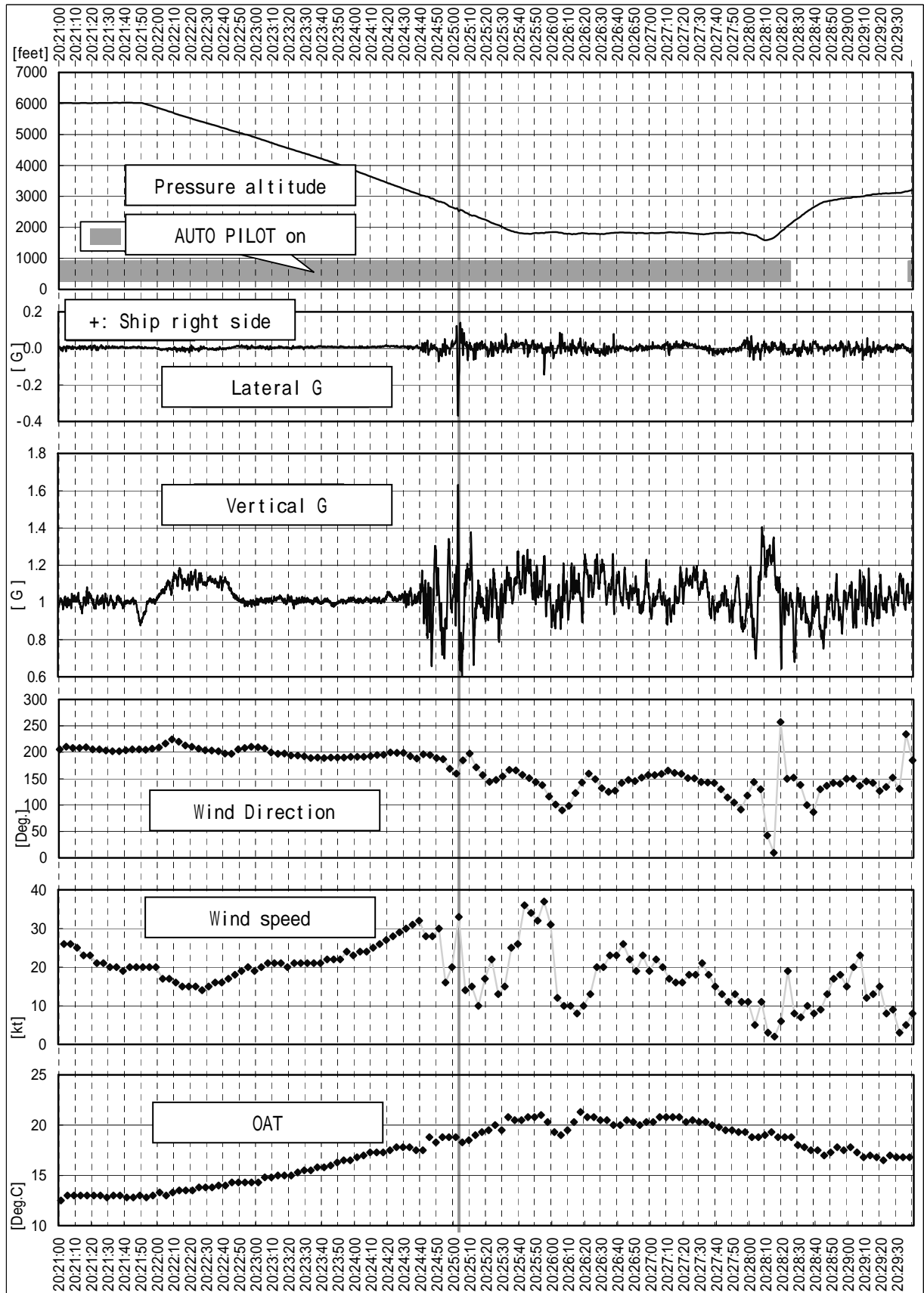

Photograph1 Seat



Armrest that the right rib of passenger A hit

Turbulence Intensity Criteria

Attachment

(OPERATIONS MANUAL SUPPLEMENT)

Condition	Code	Airplane Reaction	Cabin/Cockpit Reaction/ Guidance	Cabin service
LIGHT MINUS	LGT	Momentary, slight, erratic change in altitude and/or attitude occur	Occupants may feel a slight strain against seat belts / shoulder harnesses. Loose objects may move slightly. No difficulty in walking and cabin services,	No Difficulty
LIGHT	LGT			Available, need care for hot beverages.
LIGHT PLUS	LGT +			Need extreme care, sometimes suspend service.
MODERATE	MOD	Change in altitude/attitude occurs, airspeed fluctuations occur, but the airplane remains in positive control.	Occupants feel definite strain against seat belts / shoulder harnesses. Unsecured objects move about. Difficult to walk,	Difficult to cabin service
SEVERE	SEV	Large, abrupt changes in altitude/attitude occur. Usually large airspeed fluctuations occur. Airplane may be momentarily out of control.	Occupants forced violently against seat belts / shoulder harnesses. Unsecured objects tossed about. Walking impossible.	Cabin services impossible.
EXTREME	EXT	Airplane Tossed violently about; practically impossible to control May cause structural damage.		