

AA2018-8

**AIRCRAFT ACCIDENT  
INVESTIGATION REPORT**

**HIRATA GAKUEN  
JA500H**

October 25, 2018

The objective of the investigation conducted by the Japan Transport Safety Board in accordance with the Act for Establishment of the Japan Transport Safety Board and with Annex 13 to the Convention on International Civil Aviation is to determine the causes of an accident and damage incidental to such an accident, thereby preventing future accidents and reducing damage. It is not the purpose of the investigation to apportion blame or liability.

Kazuhiro Nakahashi

Chairman

Japan Transport Safety Board

Note:

This report is a translation of the Japanese original investigation report. The text in Japanese shall prevail in the interpretation of the report.

**AIRCRAFT ACCIDENT  
INVESTIGATION REPORT**

**AIRCRAFT DAMAGE DUE TO ROLLOVER AFTER LANDING**

**KOBE AIRPORT**

**AT AROUND 10:59 JST, MARCH 14, 2017**

**HIRATA GAKUEN**

**EUROCOPTER AS350 B3 (ROTORCRAFT), JA500H**

September 28, 2018

Adopted by the Japan Transport Safety Board

Chairman Kazuhiro Nakahashi

Member Toru Miyashita

Member Toshiyuki Ishikawa

Member Yuichi Marui

Member Keiji Tanaka

Member Miwa Nakanishi

# SYNOPSIS

## < Summary of the Accident >

On Tuesday, March 14, 2017, at around 10:59 Japan Standard Time (JST: UTC + 9 hours; all times are indicated in JST on a 24-hour clock), a Eurocopter AS350 B3, registered JA500H, operated by HIRATA GAKUEN, landed on a grass area inside the landing area of Kobe Airport and attempted to lift off again for training but rolled over in the same grass area.

There were 2 people on board the helicopter, consisting of a PIC and a pilot undergoing annual training. No one was injured.

The helicopter was destroyed, but there was no outbreak of fire.

## < Probable Causes >

It is probable that this accident occurred because, when control was transferred from the pilot in the right seat to the Pilot In Commander in the left seat immediately after the helicopter made a running landing in hydraulic system failure training and the helicopter attempted to lift off again, left rotation occurred and the helicopter rolled over to the right due to dynamic rollover in which the trailing end of the right skid, which became stuck in the ground, served as the fulcrum, causing damage to the helicopter.

Regarding the left rotation, it is probable that this occurred because the collective pitch lever rose after the transfer of control and appropriate control in response to it did not take place.

It is probable that the fact that an operation to restore hydraulic pressure was being conducted simultaneously with the transfer of control and the fact that the collective pitch lever was not being held appropriately contributed to the collective pitch lever's rise.

Abbreviations and acronyms used in this report include the following:

|             |  |
|-------------|--|
| ACCU:       | Accumulator                              |
| ASU:        | Ancillary System Unit                    |
| CG:         | Center of Gravity                        |
| EDR:        | Engine Data Recorder                     |
| FADEC:      | Full Authority Digital Engine Control    |
| KIAS:       | Kt Indicated Air Speed                   |
| HYD (HYDR): | Hydraulic                                |
| MGB:        | Main Gear Box                            |
| MRB:        | Main Rotor Blade                         |
| SCU:        | System Control Unit                      |
| SW:         | Switch                                   |
| TGB:        | Tail Gear Box                            |
| TST:        | Test                                     |
| TWT:        | Twist                                    |
| VEMD:       | Vehicle and Engine Multifunction Display |

#### Unit Conversion Table

|        |                       |
|--------|-----------------------|
| 1 ft:  | 0.3048m               |
| 1 lbf: | 0.4536kg              |
| 1 kt:  | 1.852km/h (0.5144m/s) |
| 1 kg:  | 2.205lb               |
| 1 kgf: | 9.8N                  |

# 1. PROCESS AND PROGRESS OF THE AIRCRAFT ACCIDENT INVESTIGATION

## 1.1 Summary of the Accident

On Tuesday, March 14, 2017, at around 10:59 Japan Standard Time (JST: UTC + 9 hours; all times are indicated in JST on a 24-hour clock), a Eurocopter AS350 B3, registered JA500H, operated by HIRATA GAKUEN, landed on a grass area inside the landing area of Kobe Airport and attempted to lift off again for training but rolled over in the same grass area.

There were 2 people on board the helicopter, consisting of a PIC and a pilot undergoing annual training. No one was injured.

The helicopter was destroyed, but there was no outbreak of fire.

## 1.2 Outline of the Accident Investigation

### 1.2.1 Investigation Organization

The Japan Transport Safety Board was notified of this accident's occurrence and designated an investigator-in-charge and an investigator on March 14, 2017 to investigate this accident.

### 1.2.2 Representatives of the Relevant State

An accredited representative of French Republic, as the State of Design and Manufacture of the helicopter involved in this investigation.

### 1.2.3 Implementation of the Investigation

|                           |   |
|---------------------------|---|
| March 14 and 15, 2017     | On-site investigation, interviews, and document examination |
| April 4 and 5, 2017       | Airframe examination and interviews                         |
| April 26 to June 30, 2017 | Analysis of engine data recorder                            |

### 1.2.4 Comments from the Parties Relevant to the Cause of the Accident

Comments were invited from the parties relevant to the cause of the accident.

### 1.2.5 Comments from the Relevant State

Comments on the draft report were invited from the relevant State.

## 2. FACTUAL INFORMATION

### 2.1 History of the Flight

On March 14, 2017, a Eurocopter AS350 B3 operated by HIRATA GAKUEN (hereinafter referred to as “HIRATA”) and registered JA500H (hereinafter referred to as “the Helicopter”) took off from Kobe Airport (hereinafter referred to as “the Airport”) at 10:04 to implement annual pilot training with the Pilot in Command (PIC) seated in the left seat as the pilot in charge of training and a pilot undergoing annual training (hereinafter referred to as “Pilot A”) seated in the right seat. After executing the annual training program above the ground in the northwest section of the Airport, the Helicopter conducted continuous takeoff/landing and autorotation training at the Airport, followed by hydraulic system failure training from around 10:35.

The flight plan for the Helicopter was outlined below:

|                                   |                           |
|-----------------------------------|---------------------------|
| Flight rules:                     | Visual flight rules (VFR) |
| Departure aerodrome:              | Kobe Airport              |
| Estimated off-block time:         | 10:00                     |
| Cruising speed:                   | 110 kt                    |
| Cruising altitude                 | VFR                       |
| Route                             | Kobe local                |
| Destination aerodrome:            | Kobe Airport              |
| Total estimated elapsed time:     | 1 hour                    |
| Fuel load expressed in endurance: | 2 hours                   |
| Persons on board :                | 2                         |

The flight history up to the time of the accident is outlined below, based on the statements from the PIC, Pilot A, and air traffic controllers as well as ATC communication records and images taken by an airport surveillance camera.

#### 2.1.1 History of the Flight Based on ATC Communication Records and Images Taken by an Airport Surveillance Camera

|       |  |
|-------|--|
| 10:04 | Takeoff from Kobe Airport  |
| 10:10 | Execution of training items around 10 nm northwest of the Airport  |
| 10:35 | Execution of continuous takeoff and landing practice and autorotation training at the Airport  |
| 10:59 | Conducted running landing in a grass area inside the landing area (hereinafter referred to as “Grass Area”) while executing a practice hydraulic failure, etc. |
| 10:59 | Right rollover in the Grass Area   |

#### 2.1.2 Statements of the Pilots

##### (1) PIC (Pilot in Charge of Training)

The PIC sat in the left seat and, at around 10:04, took off from the Airport with Pilot A at the controls to conduct annual training for Pilot A. The PIC implemented annual training items near an altitude of 3,000 ft in the northwest airspace of the Airport until around 10:30, and at around 10:35 returned to the Airport and conducted continuous takeoff/landing once and autorotation training three times. At the end of training, he asked the air traffic controller

for a south-side traffic pattern in order to use a grass area for training pertaining to hydraulic system Failure. He set the ACCU TST push button (see 2.11.3 (2) 1) b for details) to ON to assume a practice hydraulic failure on the southern downwind in traffic pattern of Runway 27. Pilot A set the air speed at approximately 60 kt, set the Hydraulic Cut Off switch (see 2.11.3 (2) 1) a for details) to OFF, and then set the ACCU TST push button to OFF. The helicopter received the landing clearance to Grass Area on downwind at same time was instructed to move to the S-position and to wait after landing because a departure aircraft would be taking off. At this time, PIC requested to wait at the landing location but was again instructed to move to the S position. PIC thought that a hydraulic system failure makes the flight controls heavier and thus entails a greater workload.

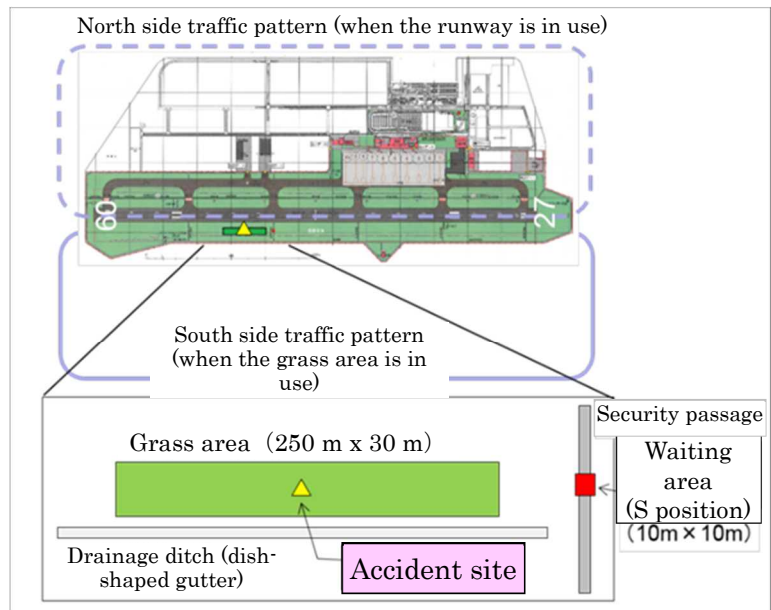

Table 1 Kobe Airport's Grass Area and S Position

And then he wanted to return to the apron quickly, he said “I’ m taking over” before the running landing had completed and took over controlling from Pilot A. The PIC held the cyclic stick with his left hand and set the Hydraulic Cut Off switch to ON with his right hand after instructing Pilot A to lock the collective pitch lever. He did not personally check that the HYDR warning light had gone out. When he subsequently re-grasped the cyclic stick with his right hand and raised the collective pitch lever with his left hand, the helicopter subsequently nosed up. He sensed that the right rear of the Helicopter was caught on something, and the Helicopter rolled over to the right side without recovering. He might have applied the left rudder as he was operating the collective pitch lever. He did not notice that the Helicopter had rotated left, and the Helicopter turned over and stopped without his understanding what was happening. He then set the master switch and engine switch to OFF, removed his seatbelt, and escaped the Helicopter.

He hurried by taking over the controls and operating the Hydraulic Cut Off switch himself because he had another task to do after finishing the training and he wanted to return to the apron as quickly as possible.

(2) Pilot A (Pilot Undergoing Annual Training)

After completing continuous takeoff-and-landing practice at the Airport, the PIC created a practice hydraulic failure by using the ACCU TST push button while they were flying down wind on the south side. Pilot A immediately set the air speed to approximately 60 kt and set the Hydraulic Cut Off switch to OFF as an emergency operating procedure. While approaching, operation of the left rudder to control direction became more involved and gradually became heavier. He made a running landing in the Grass Area with air speed of approximately 20 kt at the time of touchdown. As for the condition of the Grass Area, the



weeds appeared to be shorter than usual, but he felt that the ground was somewhat muddy. When he lowered the collective pitch lever after stopping the helicopter, the PIC said “I’m taking over” to him. Pilot A said “OK, you have control” and relaxed his hands and feet on the flight controls. He thinks the position of the flight controls was left rudder forward, and the cyclic stick was slightly to the right rear. Although he does not remember being instructed by the PIC to lock the collective pitch lever, he operated the collective pitch lever lock while looking at the caution warning panel. However, he did not visually confirm that it was locked. After the PIC set the Hydraulic Cut Off switch to ON, Pilot A confirmed that the HYDR warning light turned off. The helicopter quickly nosed up immediately after the PIC began controlling it, but Pilot A did not know that they were rotating to the left. He does not think they did anything in particular in terms of recovery, and the helicopter rolled over to the right in a state that made him think that the right back of the skid was caught. After the helicopter rolled over and stopped, he opened the left-side door and exited.

(3) Air Traffic Controller, Control Tower, Kobe Aerodrome Control Tower

The Air Traffic Controller took his position in the control tower at around 10:40. The Helicopter was conducting traffic pattern practice on Runway 27. After conducting autorotation practice once, it asked to conduct takeoff-and-landing practice in the Grass Area via the south-side traffic pattern. After he granted permission to land in the Grass Area, the Helicopter asked for permission to conduct a running landing and wait at the stop position. However, he was already expecting a departure aircraft, and so he instructed the Helicopter to move to the S position and wait on the ground. He then received a report from the departing helicopter stating that it was ready for takeoff, so he had the departure aircraft wait on the runway. After it finished its running landing, he saw the Helicopter lifted and begun turning to the left and then immediately rolled over to the right. He immediately sent out a report using the crash phone and called to the Helicopter, but there was no response.

This accident occurred at the south-side Grass Area of Kobe Airport’s runway (34°37’55”N, 135°13’22”E) at around 10:59 on March 14, 2017. (See Figure 1)

## **2.2 Injuries to Persons**

No one was injured.

## **2.3 Damage to the Helicopter**

### **2.3.1 Extent of Damage**

Destroyed.

### **2.3.2 Damage to the Helicopter Components**

- (1) Fuselage: Damaged and bent
- (2) Tail: Damaged
- (3) Engine: Damaged and deformed
- (4) Rotor system: Damaged and bent
- (5) Control system: Damaged

(See Photo 2 “Contact Marks at the Accident Site and Damage to the Helicopter”)

## **2.4 Personnel Information**

|   |                        |
|---|------------------------|
| (1) PIC Male, Age 46  |                        |
| Commercial pilot certificate (Rotorcraft)                         | March 13, 2001         |
| Specific Pilot Competence Expiry of practicable period for flight | January 27, 2019       |
| Rating for single-turbine engine (land):                          | May 27, 2002           |
| Rating for multi-turbine engine (land):                           | July 29, 2009          |
| Class 1 aviation medical certificate                              |                        |
| Validity  | October 13, 2017       |
| Total flight time   | 2,194 hours 12 minutes |
| Flight time in the last 30 days                                   | 9 hours 22 minutes     |
| Total flight time on AS350 B3                                     | 224 hours 15 minutes   |
| Flight time in the last 30 days on AS350 B3                       | 0 hours 00 minutes     |
| (2) Pilot A Male, Age 42  |                        |
| Commercial pilot certificate (Rotorcraft)                         | November 6, 2008       |
| Specific Pilot Competence Expiry of practicable period for flight | February 22, 2018      |
| Rating for single-turbine engine (land):                          | October 1, 2007        |
| Class 1 aviation medical certificate                              |                        |
| Validity  | November 17, 2017      |
| Total flight time   | 1,871 hours 48 minutes |
| Flight time in the last 30 days                                   | 3 hours 34 minutes     |
| Total flight time on AS350 B3                                     | 95 hours 21 minutes    |
| Flight time in the last 30 days on AS350 B3                       | 1 hours 37 minutes     |

## 2.5 Helicopter Information

### 2.5.1 Helicopter

|  |                      |
|--|----------------------|
| Type   | Eurocopter AS350 B3  |
| Serial number  | 7488                 |
| Date of manufacture  | October 24, 2012     |
| Certificate of airworthiness   | No. Dai 2016-374     |
| Validity   | September 27, 2017   |
| Category of airworthiness  | Rotorcraft normal N  |
| Total flight time  | 411 hours 42 minutes |
| Flight time since last periodical check<br>(one-month inspection carried out on March 7, 2017)<br>(See Figure 1 “Three Angle View of a Eurocopter AS350 B3”) | 0 hours 17 minutes   |

### 2.5.2 Weight and Balance

At the time of the accident, the weight of the Helicopter is estimated to have been 1,817 kg, the position of the front-back center of gravity is estimated to have been 3.33m aft of the base plane (front edge location of the fuselage’s nose), and the lateral center of gravity is estimated to have been 0.0 m with no left-right difference. It is highly probable that each was within the allowable ranges (maximum takeoff weight of 2,250 kg, position of front-back center of gravity with respect to the Helicopter’s weight at the time of the accident of 3.17 m to 3.48 m, and lateral center of gravity of between 0.18 m left and 0.14 m right).

## 2.6 Meteorological Information

Aeronautical weather observations at the Kobe Airport around the time of the accident were as follows.

11:00 Wind direction 350°; Wind velocity 15 kt; Prevailing visibility more than 10 km;  
 Current weather: clear  
 Cloud: Amount 1/8, Type cumulus, Cloud base 3,500 ft  
 Amount 3/8, Type stratocumulus, Cloud base 14,000 ft  
 Temperature 11°C; Dew point 1°C; Altimeter setting (QNH) 29.88 inHg

Changes in wind direction and wind speed near the runway at the time of the accident were as shown in Table 1.

Table 1 Changes in Wind Direction and Wind Speed at the Time of the Accident

| Time           | 10:59:00 | 10:59:10 | 10:59:20 | 10:59:30 | 10:59:40 |
|----------------|----------|----------|----------|----------|----------|
| Wind direction | 354°     | 355°     | 354°     | 354°     | 353°     |
| Wind speed     | 15kt     | 15kt     | 14kt     | 14kt     | 13kt     |

## 2.7 Information on the Engine Data Recorder

The Turbomeca Arriel 2D engine installed on the Helicopter was equipped with a FADEC and an EDR. They recorded data that included the parameters shown in Table 2 at one-second intervals from immediately prior to engine start until record stop after 3,921 seconds. In particular, the period between 3,908 seconds until record stop was recorded at 0.02-second intervals in the EDR. Additionally, event data indicating an abnormality in the Helicopter at the time of the accident that were outputted from the EDR were recorded in a VEMD installed in the cockpit; however, no other data indicating abnormality existed.

Regarding the parameters of Table 2, engine data recorded in the EDR are provided in Table 3. An event indicating an XPC\_1 failure collective pitch anticipator position abnormality was recorded at 3,913.16 seconds (1 hour, 5 minutes, and 13.16 seconds) from the record start.

Table 2: Main Engine Parameter Types

| Parameter | Unit      | Parameter meaning                           | Main items checked  |
|-----------|-----------|---|---|
| P0        | mbar      | Atmospheric pressure                        | Check of altitude change based on air pressure difference |
| XPC       | %         | Collective pitch anticipator position       | Check of pilot control                                    |
| TRQ       | %<br>(* ) | Torque<br>(*Converted based on 100%=951 Nm) | Check of engine output changes                            |
| NR        | %         | Main rotor revolutions                      | Check of engine start, stop, and change                   |
| N1        | %         | Gas generator revolutions                   |   |
| N2        | %         | Free turbine revolutions                    |   |

Table 3 EDR Data From Time of Engine Start to Time of Record Stop

| Time (sec) | Condition                                       | P0 (mbar) | XPC (%) | TRQ (%) | NR (%) | N1 (%) | N2 (%) |
|------------|---|-----------|---------|---------|--------|--------|--------|
| 150.00     | Engine start                                    | 1,010.6   | 9       | 15      | 73     | 67.4   | 72.7   |
| 3,908.34   | Start of 20 msec (0.02-second intervals) record | 1,011.5   | 12      | 15      | 101    | 76.6   | 99.5   |
| 3,913.16   | XPC_1 failure                                   | 1,010.5   | 32      | 74      | 100    | 86.9   | 76.3   |
| 3,921.48   | EDR record stop                                 | 1,011.8   | 42      | 158     | 0      | 20.0   | 0.0    |

## 2.8 Accident Site and Wreckage Information

### 2.8.1 Situation at the Accident Site

- (1) At the time of the accident, the Grass Area was covered with weeds of no more than approximately 10 cm in height and the surface soil was in a slightly soft state.
- (2) As is shown in Figure 2, at the accident site, the Helicopter was rolled over with the nose pointed toward 160 degrees and the fuselage's right side facing down. There were marks made by the skids measuring approximately 2 meters in width, approximately 32 meters in length, and approximately 8 cm in depth running toward the Helicopter on the eastern side of the Helicopter. The marks changed position to the left and right approximately 10 meters before the Helicopter. Additionally, a contact mark of approximately 1 meter in length, where the Grass Area had been lacerated in the direction of 320 degrees, was located near the end of the approximately 32-meter marks. The northwest edge of the mark was deeply gouged and the Grass Area had been turned up. Furthermore, soil that had become attached when the Helicopter slipped laterally remained on the strip surface on the rear of the Helicopter's right skid. Marks where the three main rotor blades contacted the ground when the Helicopter rolled over to the right existed in four locations with lengths of approximately three to four meters near the main rotor blades. Portions of the main rotor's outer skin and inner urethane were scattered in an area measuring 35 meters on the east side, 10 meters on the west side, 16 meters on the south side, and 10 meters on the north side of the Helicopter.

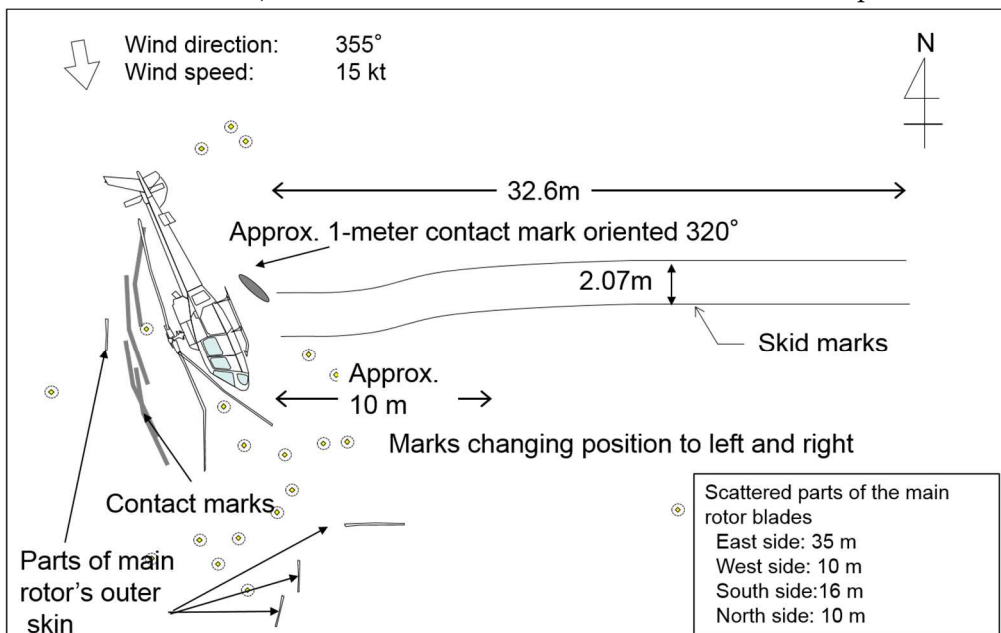

Figure 2 Situation at the Accident Site

## 2.8.2 Damage Details

### (1) Fuselage

- The outer skin that enclosed the main transmission was damaged and bent.

### (2) Tails

- The outer skin of the right-side forward section and tail drive shaft cover was damaged.
- There was no mud on or damage to the tail skid.

### (3) Engine

- The engine mount was deformed and/or broken, and the entire engine had shifted to the right.
- Each section was damaged or twisted.

### (4) Rotor system

- All of the main transmission's support bars were broken.
- The rotor head's Star Flex was broken inside the sleeve assembly and the entire sleeve assembly was damaged.
- All of the main rotor blades' outer skin was damaged and some parts were scattered throughout the area.
- The tail rotor drive shaft was separated from the engine's output shaft and part of it had fallen onto the ground.

### (5) Control system

- All of the main rotor's servo actuator input rods were damaged.

(See Photo 2 "Contact Marks at the Accident Site and Damage to the Helicopter")

## 2.9 Information on Fire and Firefighting

The Helicopter was destroyed, but there was no outbreak of fire.

The Kobe Airport Fire Rescue Team received a report via the crash phone at 11:00 and arrived at the accident scene at 11:03. However, the team did not spray water because there was no fire. The two pilots had already escaped from the Helicopter on their own when the team arrived at the site.

## 2.10 Information on Tests and Research

AS350 B3 was a helicopter with a single clockwise-spinning\*1 rotor having three main rotor blades. With AS350 B3, operation of the right rudder is necessary when the collective pitch lever is raised to stop the antitorque action that accompanies the higher output. Because the control input varies depending on the aircraft's weight, wind direction and wind speed, and other factors, the required torque and rudder position when hovering 5 ft in ground effect were calculated using a computation model for AS350 B3 possessed by the designer and manufacturer. The results are presented in Table 4.

Table 4 Required Torque and Rudder Position when Hovering at Five Feet

| Helicopter weight | Relative wind direction and wind speed | Collective pitch lever position | Required torque | Rudder position |
|-------------------|--|---------------------------------|-----------------|-----------------|
| 1,820 kg          | 0° 0 kt                                | 38%                             | 48%             | 56%             |
|                   | Right 80° 15 kt                        | 36%                             | 45%             | 50%             |

Based on outside air temperature of 11.8°C, air pressure of 1,010.3 mbr, and the position of center of gravity described in 2.5.2

---

\*1 Clockwise: Clockwise when viewed from above.

Collective pitch: - 0% full low pitch - 100% full high pitch.

Rudder pedals: - 0% left pedal forward - 100% right pedal forward

From the results of the computation, the torque necessary for hovering under the environmental conditions at the time of the accident was 45% and the rudder position was the neutral position of 50%.

The Flight Manual for the AS350 B3 provides the following as the demonstrated wind direction and speed envelope during hovering.

*Hovering with winds from any direction up to 17 kt (31 km/h) has been demonstrated over the entire flight envelope, although it is not to be taken as a limit.*

*For example hover at sea level at maximum gross weight and for all c.g. locations has been substantiated at 30 kt (55 km/h).*

## **2.11 Additional Information**

### **2.11.1 Use of the Grass Area by Rotorcraft**

The Grass Area that became the site of the accident is a place within the landing area on the south side of the Airport's runway that rotorcraft owned by businesses located at the Airport are permitted to use on a temporary basis. Mainly skid-type\*2 rotorcraft temporarily use the Grass Area for practice of hovering flight and takeoffs and landings. The Kobe Aerodrome Air Traffic Services Procedures stipulate that, when there is a rotorcraft taking off or landing on the runway, training flights will be made to wait on the ground in the Grass Area or the waiting area of the S position.

### **2.11.2 Flight Form of the Helicopter Based on Images Taken by an Airport Surveillance Camera**

A check of the Helicopter's flight form prior to the accident from images taken by an airport surveillance camera installed on the airport terminal building showed that the configuration was as follows.

At 10:58:33 the Helicopter passed near an area directly to the side of the airport surveillance camera at a height above ground level (AGL) of approximately 41 meters and then landed 765 meters distant from this point at 10:59:12. During this time, the Helicopter's angle of approach was 3.1 degrees and rate of descent was 210 ft/minute. The Helicopter's average speed calculated for the space between the point directly to the side of the airport surveillance camera and around 170 meters before the runway touchdown point (hereinafter referred to as "the Touchdown Point") was 50.2 kt, and its average speed calculated for the space between around 170 meters before the Touchdown Point and the Touchdown Point was 21.5 kt. At around 10:59:08, the Helicopter raised its nose and reduced speed and then subsequently returned to near level flight; however, its rate of descent became somewhat large and it touched down and made a running landing. When the Helicopter attempted to lift off immediately after stopping, a situation was observed whereby it rotated to the left while leaning to the right without raising its nose significantly, and at around 10:59:26, as it turned toward the south side, it rolled over to the right and its main rotor contacted with the ground.

### **2.11.3 Functions of AS350 B3**

#### **(1) Movement of the main rotor head**

The main rotor head is equipped with a "Star Flex" that has 3 arms flexible in flapping.

---

\*2 A "skid" is a type of helicopter landing gear. A "skid-type" helicopter touches down on two skids rather than on wheels.

Rigid sleeves join the blades to the star arms. Flexible couplings have been fitted between the sleeve and the star arm: spherical thrust bearing and frequency adapter. The “Star Flex” assembly is comparable to a hinged rotor with elastic return in flapping,\*<sup>3</sup> dragging\*<sup>4</sup> and feathering\*<sup>5</sup>. In case of hydraulic off assistance (by failure of the hydraulic system or by action to the pilot), the Star Flex, frequency adapter, and spherical thrust bearing attempt to return the flight controls to the neutral position corresponding to the equilibrium with the aerodynamic/inertia loads from the main rotor head. Consequently, when putting the flight controls into a position other than the neutral position, it is necessary for the pilot to maintain that position with control force.

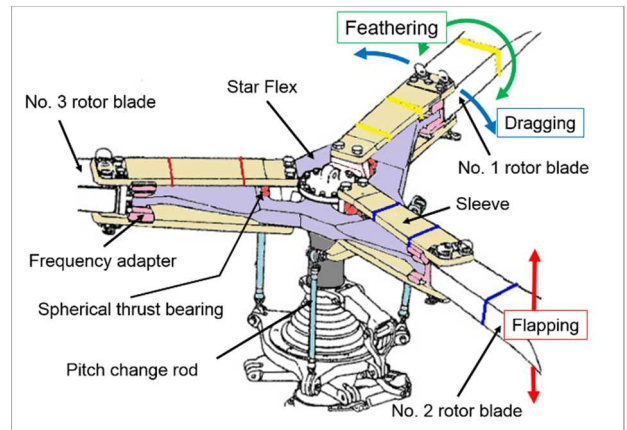

Figure 3 Main Rotor Head

(2) Hydraulic system

1) Hydraulic system

Hydraulic pressure is used in the control system of AS350 B3 to reduce the workload on the pilot. Hydraulic pressure reduces the control force of the cyclic stick, collective pitch lever, and yaw control pedals (hereinafter referred to as “rudder pedals”).

The hydraulic system has three main rotor servos and a tail rotor servo for directional control. Each main servo is equipped with a safety unit (accumulator) that can continue to

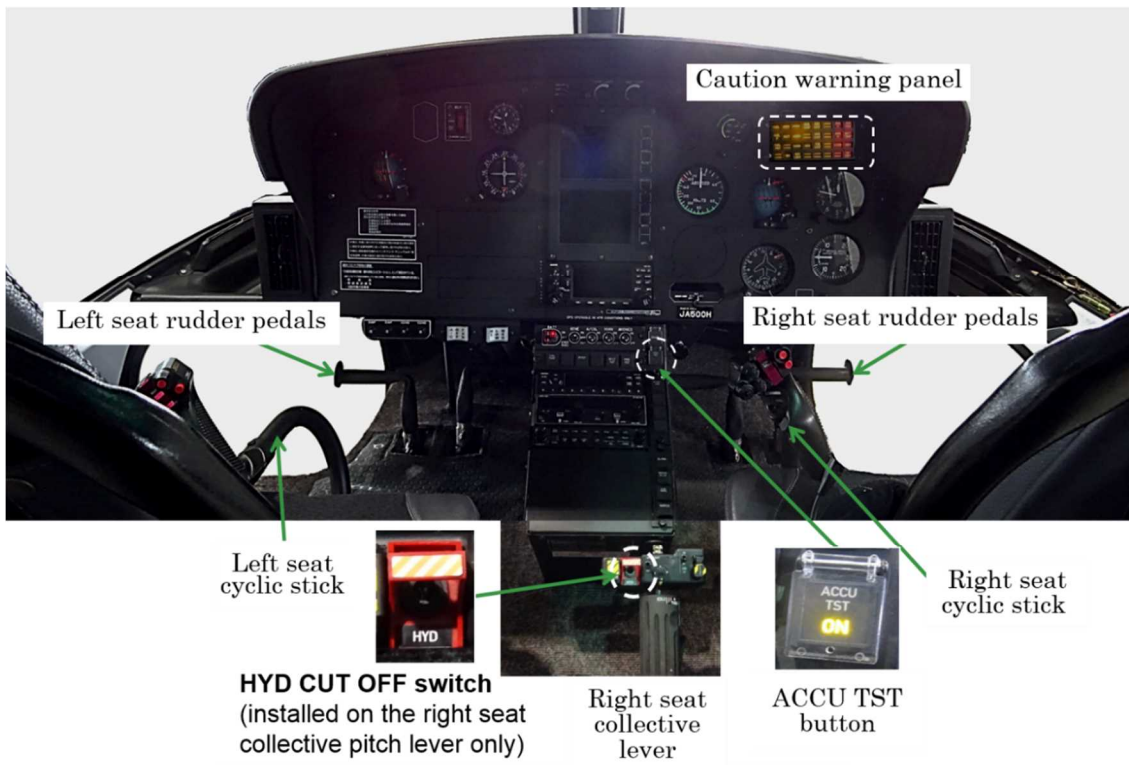

Photo 1 Cockpit of the JA500H

\*3 “Flapping” refers to movement in an up-down direction with respect to the rotor blades’ surface of revolution.  
 \*4 “Dragging” refers to leading or lagging movement in the direction of rotation with respect to the rotor blades’ surface of revolution.  
 \*5 “Feathering” refers to movement that changes the pitch angle in a twisting direction with respect to the rotor blades’ angle of incidence.

provide hydraulic assistance for a limited time even if there is a drop in hydraulic pressure. The tail rotor servo is equipped with a safety unit (yaw load compensator) that can continue to provide force assistance if there is a drop in hydraulic pressure. The pilot must enter the recommended safe speed range during the limited time given by the main servo accumulators. The hydraulic system is controlled using the following two switches. (See Photo 1 and Appendix Figure 2)

a Hydraulic Cut Off switch

The Hydraulic Cut Off switch is a switch fitted with a guard that is installed on the collective pitch lever of the right seat only. It has two positions: ON and OFF. Ordinarily the switch is left in the ON position, and if the hydraulic system is functioning normally, hydraulic pressure is provided to the main rotor servos. When the OFF position is selected, the main rotor servos' accumulators are immediately depressurized, and the control force of the cyclic stick and collective pitch lever increases immediately. However, the assisting function of the tail rotor load compensating system\*<sup>6</sup> is still maintained and control force assistance is still provided to the rudder pedals.

b Accumulator Test push button

This is a push-button switch on the center console that is marked "ACCU TST." It has two positions: ON and OFF. It is normally left in the OFF position. When the ON position is selected, the main rotor accumulators provide hydraulic assistance for a limited time. Because the load compensator is depressurized, the rudder pedals don't have any assistance anymore and their control force immediately increases in relation with the aircraft's speed.

When the Hydraulic Cut Off switch is set to OFF with the ACCU TEST push button set to ON, the rudder pedals don't have any assistance anymore while the control force of the cyclic stick and collective pitch lever increases in relation with the aircraft's speed.

2) Control force of the collective pitch lever and cyclic stick when the hydraulic system is off

When the hydraulic system is switch to OFF, the collective pitch lever tends to return to the neutral position, where level flight in the recommended safe speed range of 40 to 60 kt can be attained with zero input from the pilot. The cyclic stick's control force at this time requires pushing force of approximately 9 lbf to the left and approximately 11 lbf forward due to the aerodynamic characteristics of the clockwise rotor rotation.

3) Restoration of the hydraulic system

If, after the hydraulic system depressurizes, the Hydraulic Cut Off switch is returned to the ON position and the ACCU TST push button is in the OFF position, the hydraulic system will pressurize and the main rotor servos' accumulators will also pressurize. It ordinarily takes three or four seconds for hydraulic pressure to rise up to normal pressure.

(3) Lock of the collective pitch lever

AS350 B3 are equipped with a hooking lock and hooking blade that allow locking of the collective pitch lever near its lowest position. This device is installed on the right seat's collective pitch lever only. The Flight Manual states that the device should be used when locking the collective pitch lever when the starting or stopping the engine or when inspecting the hydraulic system during parking. In case of putting it into a locked state, puts the collective pitch lever into its lowest position, hooks the hooking blade onto the hooking lock's slot, and then relaxes hand. To disengage from the locked state, the person can release the collective

---

\*<sup>6</sup> A "tail rotor load compensating system" is a hydraulic system that assists the pilot's rudder control against the main rotor's antitorque action.



pitch lever by pushing down on it slightly. If, during a ground operation inspection, the Hydraulic Cut Off switch is set to OFF without locking the collective pitch lever, the collective pitch lever will move up from the neutral position. Thus, it must be confirmed that the collective pitch lever is properly locked.



Figure 4 The Lock of Collective Pitch Lever

#### 2.11.4 Emergency Operating Procedure and Training Procedure for Hydraulic System Failure

An emergency operating procedure and training procedure for hydraulic system failure (Flight Manual Supplement) are established in the Flight Manual for AS350 B3 (revised on January 5, 2017). The following are mentioned in the cautions, notes, and text concerning use of the “ACCU TST” switch.

- (1) Emergency Operating Procedure for Loss of Hydraulic Pressure

*Keep aircraft at a more or less level attitude.*

*Avoid abrupt maneuvers.*

**CAUTION\*7**

*Do not use [ACCU TST] pushbutton as this will depressurize the yaw load compensator resulting in heavy pedal control loads.*

*Do not attempt to carry out hover flight or any low speed maneuver.*

*The intensity and direction of the control feedback force will change rapidly. This will result in poor aircraft control and possible loss of control.*

*As control loads increase, be careful not to inadvertently move twist grip out of FLIGHT*

\*7 CAUTION (yellow): Indicates an operational procedure, step, or other action that may cause damage to or destroy aircraft components or equipment if not conducted with care.

*position (TWT GRIP light off).*

**NOTE**

**The accumulators contain sufficient pressure to secure flight and to reach the hydraulic failure safety speed.**

**• HIGE, Takeoff, Final: (if immediate landing is possible)**

1. Land normally
2. Twist grip.....Set to IDLE position
3. Collective pitch.....LOCK
4. Engine starting selector .....OFF

**• In flight: Smoothly,**

1. IAS.....SET to between 40 and 60 kt(74 Km/h and 111 Km/h)  
(hydraulic failure safety speed)
2. Hydraulic cut-off switch(collective pitch).....OFF

Pilot has to exert forces: - on collective increase or decrease around no force feedback point,

- on forward and left cyclic.

**LAND AS SOON AS POSSIBLE**

**NOTE**

**Speed may be increased as necessary but control loads will increase with speed.**

**3. Approach and landing: over a clear and flat area**

- Perform a flat approach into wind
- Make a no-hover slow running landing at around 10 kt (18.5 km/h)
- Do not perform hover or taxi without hydraulic pressure

**4. After landing:**

- Collective pitch .....LOCK
- Shutdown procedure .....Apply

*Do not use [ACCU TST] pushbutton as this depressurize the yaw load compensator in heavy pedal control loads.*

**3. Approach and landing: over a clear and flat area**

- Perform a flat approach into wind

**(2) Training Procedure for Hydraulic System Failure**

A training procedure for hydraulic system failure of the AS350 B3 is established in the Flight Manual Supplement. It states that simulated hydraulic failure training must be conducted using the ACCU TEST function.

When the ACCU TEST push button is set to ON, a gong warning sounds and the HYDR warning light comes on. The control system can be controlled with the accumulators' hydraulic pressure.

**CAUTION**

*Do not perform hover or taxi without hydraulic assistance.*

*As control loads change, be careful not to inadvertently move the twist grip out of FLIGHT position.*

*If the [ACCU TST] pushbutton on the SCU is not reset, hydraulic assistance cannot be*

restored.

**NOTE\*8**

*If necessary during the training exercise, hydraulic assistance can be restored by resetting [ACCU TST] pushbutton (during STEP 1) or by setting the hydraulic cut-off switch on collective pitch to ON (during the STEP 2).*

• ***Before engaging the training procedure:***

- *It is recommended to train with low aircraft weight as higher weight leads to higher control loads.*
- *The hydraulic failure training procedure should be performed close to an airfield that is suitable for a running landing.*
- *Hydraulic system can be switched on at any time but be prepared for a significant decrease of cyclic and collective control loads.*
- *Take care that the hydraulic cut-off switch is never in OFF position when the [ACCU TST] pushbutton is in ON position*

**STEP 1: FAILURE SIMULATION**

• ***In steady flight conditions:***

1. Instructor ..... [ACCU TST]: ON position:
  - CHECK **HYDR** flashes + Gong
2. Trainee ..... **Safety speed** to between 40 and 60 kt  
(74 and 111 km/h)

• ***Once safety speed reached:***

3. Instructor ..... [ACCU TST]: Reset to OFF position:
  - CHECK **HYDR**

**STEP 2: HYDRAULIC FAILURE TRAINING PROCEDURE**

4. Hydraulic cut-off switch ..... OFF:
  - CHECK **HYDR** +Gong
  - Control loads are increased

5. Perform a flat approach into wind
6. Make a no-hover, slow running landing at around 10 kt (18.5 km/h)

***Do not perform hover or taxi without hydraulic pressure.***

• ***After landing:***

7. Hydraulic cut-off switch ..... Reset to ON to restore hydraulic assistance before subsequent takeoff or hovering flight
  - CHECK **HYDR** within 3 sec.

**2.11.5 Circumstances of Education Concerning the Transfer of Control Procedure in Training by HIRATA**

At the time of the accident, there were no established in-house procedures for transferring control in training conducted by HIRATA. The procedure for transferring control during training was conducted with reference to clear transfer of flight control in Chapter 9 of *Koku Kyokan*

---

\*8 Note (black): Indicates an operational procedure, condition, or other item that must be emphasized.

*Handobukku* (Aviation Instructor's Handbook).<sup>\*9</sup>

The following is stated in *Koku Kyokan Handobukku* as a point to remember in clear transfer of flight control, given that many accidents occur as a result of poor communication or misunderstandings between trainees and aviation instructors.

*The student should stay on the controls and keep flying the aircraft until the instructor says, "I have the flight controls." There should never be any doubt about who is flying the aircraft.*

---

<sup>\*9</sup> *Koku Kyokan Handobukku*. translated by Iwao Shiraishi, Hobun Shorin, April 1, 2002 (first edition), 9-9, p. 9-10.

## 3. ANALYSIS

### 3.1 Qualifications of Personnel and Others

The PIC and Pilot A had both valid airman competence certificates and valid aviation medical certificates.

### 3.2 Airworthiness Certificate

The Helicopter had a valid airworthiness certificate, and had been maintained and inspected as prescribed.

### 3.3 Relationship with Meteorological Conditions

As was stated in 2.6, In the weather at Kobe Airport at the time of the accident, there were not clouds to be obstacles for flying and the visibility was good. However, the instantaneous wind direction and wind speed between the time the Helicopter made a running landing until it attempted to lift off again were 355° and 15 kt, and a relative wind was blowing almost directly from the right in relation to Runway 27. Thus, it is probable that the wind at the time of the accident affected the Helicopter's directional control.

### 3.4 Analysis based on the Engine Data and Images from the Airport Surveillance Camera

#### 3.4.1 Main Record from Engine Start until EDR Record Stop

For the engine data mentioned in 2.7, time calibration was conducted by matching the time recorded on the airport surveillance camera's images to a benchmark of 10:59:26, which was when the Helicopter rolled over to the right. From 2.1.2, 2.7, and 2.11.2, the EDR data for the Helicopter for the period between engine start and record stop were as shown in Table 6.

Given that the hovering torque at 10:48:18, which was after the autorotation training conducted prior to the accident, was 47% and the torque was also 47% just before the Helicopter rolled over to the right at 10:59:25, it is probable that output had risen to a point that made hovering possible at the time of the accident.

#### 3.4.2 Engine Data from Running Landing during Hydraulic System Failure Training until the Right Rollover

From 2.7 and the EDR data of Appendix Figure 3, at around 10:59:08, speed was reduced with raising of the collective pitch lever and torque was temporarily rose from 25% to 40% to conduct a running landing. The Helicopter touched down at around 10:59:12 and at around 10:59:18 torque fell to 15% with lowering of the collective pitch XPC value of the lever and stopped. The collective pitch XPC value of the lever was lowered to its lowest position at around 10:59:21. However, the XPC value of the lever was not kept still but was instead raised to approximately 40%, and at around 10:59:26 there was a sudden change with four or five up and down cycles between 0% and 100% between 10:59:26 and 10:59:27, after which it stopped near 40%. Given that the movement of the collective pitch XPC value of the lever after the main rotor blades contacted with the ground was approximately 90 cm/second, it is probable that a position sensor error occurred following contact with the ground. Torque followed the movements of the collective pitch XPC value of the lever, becoming 40% at around 10:59:23 and reaching its maximum value together with the other engine

data at around 10:59:26. Additionally, N2 became 0% at 10:59:27 and remained there. From these changes in EDR data, it is considered highly probable that the main rotor contacted the ground between 10:59:26 and 10:59:27.

Table 6 EDR Data of the Helicopter

| Time     | Situation                                | P0<br>(mbar) | XPC (%) | TRQ<br>(%) | NR<br>(%) | N1(%) | N2 (%) |
|----------|--|--------------|---------|------------|-----------|-------|--------|
| 9:56:43  | Engine start                             | 1,010.6      | 9       | 15         | 73        | 67.4  | 72.7   |
| 10:01:47 | Hovering (beginning of movement)         | 1,010.6      | 39      | 51         | 101       | 86.1  | 100.8  |
| 10:48:18 | Hovering following autorotation training | 1,010.6      | 40      | 47         | 101       | 86.7  | 100.8  |
| 10:59:25 | 1 second before XPC_1 failure            | 1,011.5      | 41      | 47         | 100       | 86.1  | 100.7  |

\* XPC is the anticipator potentiometer position connected to the collective pitch.  
Theoretical value of the XPC of 11% corresponds to a full low collective pitch position and XPC 91% corresponds to full high collective pitch position.

### 3.5 Damage to the Helicopter

As was described in 2.1.2 and 2.7, it is considered highly probable that there were no abnormalities with the Helicopter prior to the accident. From the circumstances of the damage to the Helicopter described in 2.3 and 2.8.3, it is considered highly probable that damage of the Rotorcraft occurred when the main rotor contacted with part of the Rotorcraft and the ground. Additionally, from 3.4.2, it is considered highly probable that the engine was operating normally until the main rotor contacted with the ground and that it was damaged when the main rotor suddenly stopped.

### 3.6 Flight Conditions of the Helicopter Until the Accident

#### 3.6.1 Conditions from Takeoff until Prior to the Start of Hydraulic System Failure Training

As was described in 2.1.2 and 2.7, it is highly probable that the Helicopter took off from Kobe Airport at 10:04 and that no phenomena that influenced the accident occurred during the annual training items in the air and continuous takeoff and landing practice.

#### 3.6.2 Conditions of Running Landing in the Hydraulic System Failure Training

##### 3.6.2.1 Impact on Control Force of Directional Control from Differences in Training Procedures

Compared to the AS350 B3 hydraulic system failure training procedure that was described in 2.11.4, the training procedure implemented on the Helicopter that was described in 2.1.2 had a reverse operating order in that the Hydraulic Cut Off switch should have been set to OFF after setting the air speed of the Helicopter to a safe speed of approximately 60 kt and resetting the ACCU TST push button. It is probable that the PIC and Pilot A were conducting the hydraulic system failure training procedure without accurately understanding it. It is probable that, consequently, the tail rotor load compensating system mentioned in 2.11.3 (2) did not function, that the rudder's control force became excessive during landing, and that directional control was difficult.

##### 3.6.2.2 Influence of the Wind During Running Landing

Given that, as was described with regard to running landing in 2.6 and 2.11.4, the wind was

blowing at 355° and 15 kt in relation to Runway 27 when the Helicopter should have been conducting running landing directly into the wind, it is considered probable that the Helicopter was conducting running landing in a relative wind blowing almost directly from the right. Given that, ordinarily, when on the final approach course, it is necessary to move the cyclic stick to the right and operate the left rudder to control direction in order to prevent the helicopter's being swept to the left, it is considered probable that the Helicopter's left rudder pedal position was even further forward left than it would be when conducting running landing directly into the wind.

### **3.6.2.3 Conditions of Running Landing**

Given that, as was described in 2.11.2, the Helicopter's angle of approach was 3.1 degrees and rate of descent was 210 feet/minute until the point that it touched down during running landing, it is considered probable that running landing was being conducted with a shallow angle of approach<sup>\*10</sup> in accordance with in the Flight Manual mentioned in 2.11.4. Additionally, given that the Helicopter's average speed was approximately 50 kt from the point directly to the side of the airport surveillance camera at the time of its running landing until 170 meters before the touchdown point, that its average speed was approximately 20 kt from there until its touchdown, and that its speed was as described in 2.1.2, it is considered probable that the Helicopter was in a situation requiring somewhat large deceleration prior to touching down. The deceleration prior to touchdown that took place at around 10:59:08 involved decelerating by lifting the nose and then returning the nose's position to near level. However, given that the Helicopter was touching down in a state in which its rate of descent was being increased slightly, it is considered probable that the skid became stuck in the slightly soft Grass Area when it touched down.

(See Appendix 4 Estimated Flight Situation Form of the Helicopter at the Time of the Accident)

### **3.6.3 Situation at the Left Rotation After Stopping**

#### **3.6.3.1 Collective Pitch Lever Position Following the Running Landing**

As was described in 2.1.2, Pilot A transferred control to the PIC after completing the Helicopter's running landing. Thinking that the collective pitch lever was locked, the PIC transferred the cyclic stick from his right hand to his left hand and set the Hydraulic Cut Off switch to ON with his right hand. Based on the EDR data of Appendix Figure 4, the position of the collective pitch lever was at its lowest position at around 10:59:21. However, given that it did not stay there and continued to move, it is considered probable that, while the PIC was transferring the cyclic stick to operate the switch, the lock became disengaged and the collective pitch lever rose up. It is considered probable that, because the collective pitch lever was not being properly held, the collective pitch lever continued to rise until torque came close to around 40% during the three or four seconds until hydraulic pressure was restored after the Hydraulic Cut Off switch was switch to ON in the manner described in 2.11.3 (2) 2) and 3).

#### **3.6.3.2 Start of the Left Rotation**

As was described in 2.10, if the right rudder is operated while the collective pitch lever is raised, the action that stops the antitorque action generated by the increasing output becomes deficient and the helicopter begins rotating to the left. After control was transferred, it is considered probable that, as was described in 2.1.2, the rudder pedal was forward left and the cyclic stick was

---

<sup>\*10</sup> According to the FAA Helicopter Flying Handbook, a normal angle approach is between 7° and 12° and a shallow angle approach when conducting a running landing is between 3° and 5°.

to the right rear. Given that the main rotor disk inclined to the right rear and, further, the right rudder was not operated while the main rotor's thrust increased due to the raising of the collective pitch lever described in 3.6.3.1, it is considered probable that the Helicopter rose at the nose and began rotating left while inclining to the right.

Additionally, regarding the PIC's statement that he may have applied the left rudder, as was described in 2.1.2 (1), it is considered probable that the hydraulic pressure had not adequately recovered and therefore the right rudder was not in a state in which it could be easily applied during the time that the collective pitch lever was raised. Moreover, regarding the sudden rise of the nose described in 2.1.2 (1) and (2), based on the fact that there was no mud on the tail skid and on the analysis of the images described in 2.8.2 (2) and 2.11.2, it is considered probable that the PIC confused the Helicopter's rotation to the left while inclining to the right as a sudden rising of the nose.

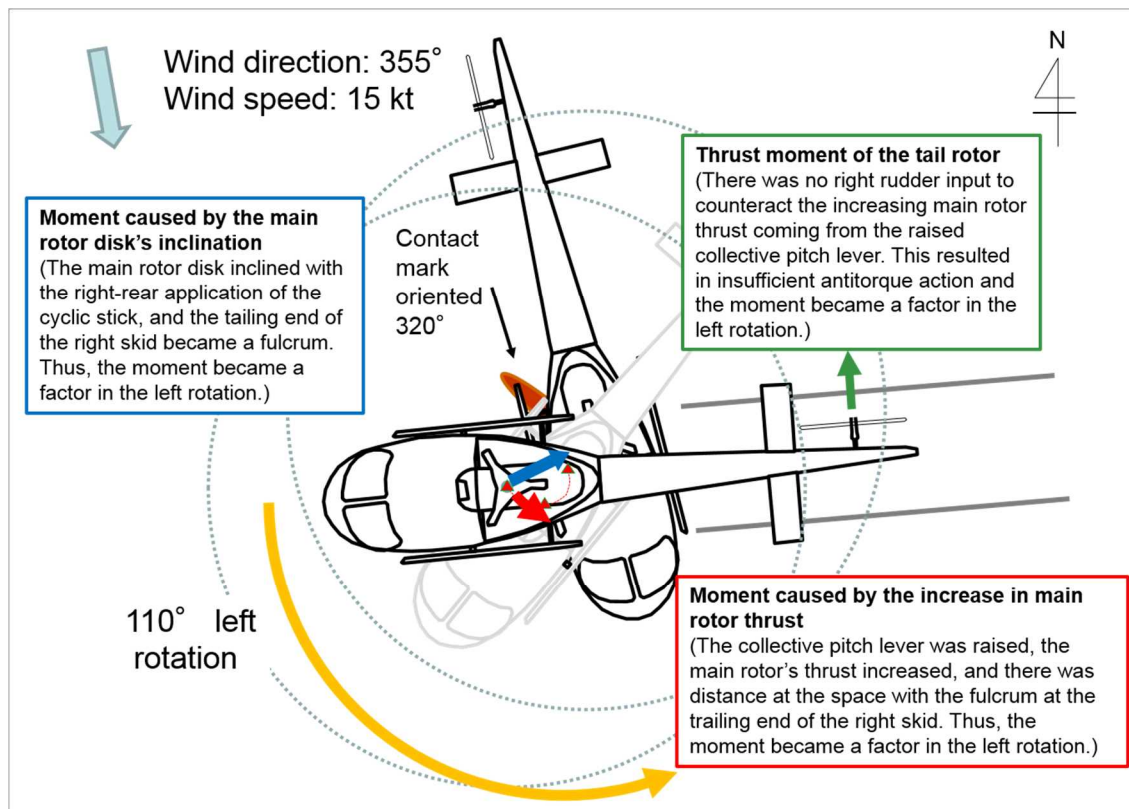

Figure 5 Moments involved in the Left Rotation

### 3.6.4 Beginning of the Right Rollover

#### 3.6.4.1 Contact Marks that were the Fulcrum of the Right Rollover

From 2.8.1 and 3.6.3.2, given that the contact mark of approximately 1 meter in length that was oriented 320 degrees and located to the east of the place where the Helicopter rolled over was deeply gouged at its end and the Grass Area was turned up, it is considered probable that strip on the rear part of the right skid became the fulcrum for the Helicopter's right rollover.

#### 3.6.4.2 The Helicopter's Right Rollover

Regarding the Helicopter's right rollover, from 3.4.2 and 3.6.3, given that the nose rose, the left rotation continued with a right incline, and there was no lowering of the collective pitch lever, it is considered probable that the right inclination became even larger when the Helicopter rotated 110° to the left and, as is shown in Figure 6, the horizontal component of the main rotor's thrust



and the right lateral force generated by the left rotation caused a roll moment with the strip on the rear part of the right skid serving as the fulcrum, thereby creating a dynamic rollover\*<sup>11</sup> and causing the Helicopter to roll over to the right.

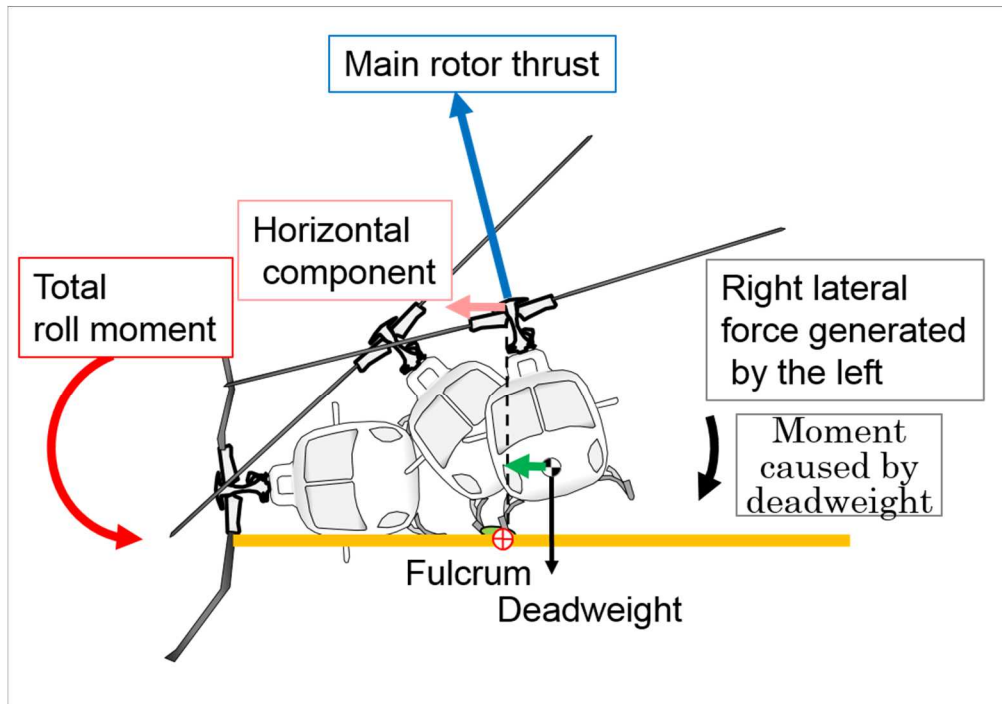

Figure 6 Dynamic Rollover of the Helicopter

### 3.7 Procedure and Control During Transfer of Control

#### 3.7.1 Procedure and Control During Transfer of Control

- (1) Lock of the collective pitch lever position

Regarding the collective pitch lever's not being locked while the PIC operated the Hydraulic Cut Off switch, from 3.6.3.1, it is somewhat likely that either the collective pitch lever's hooking lock was not securely locked on the hooking blade or the lock became disengaged when either the left or right collective pitch lever was momentarily pushed down.

- (2) Position correction of the flight controls and operation of the Hydraulic Cut Off switch during transfer of control

As was described in 2.1.2, the transfer of control from Pilot A to the PIC occurred immediately after a running landing made during hydraulic system failure training. As was described in 2.11.3 (2), the Hydraulic Cut Off switch was installed on the right seat's collective pitch lever only. Because, for a pilot sitting in the right seat, this switch could be operated while holding the grip of the collective pitch lever without having to lock the collective pitch lever, the switch should have been operated by Pilot A. Having been informed by the PIC that the PIC would take control, Pilot A relaxed his hands and feet from the flight controls without returning the cyclic stick and rudder pedals to their neutral positions. The PIC, thinking that the collective pitch lever was locked, took his hand off the collective pitch lever's grip, grasped

\*<sup>11</sup> "Dynamic rollover" refers to a situation in which a roll movement to the side occurs when a helicopter is landing or taking off. When a roll movement begins with a skid or a tire of the helicopter serving as the fulcrum, the main rotor's thrust acts to increase the roll movement. Consequently, the helicopter will eventually exceed the critical rollover angle and overturn unless the main rotor's thrust is reduced.

the cyclic stick with his left hand without correcting its position, and, further, operated the Hydraulic Cut Off switch with his right hand without correcting the position of the rudder pedals. It is considered probable that these actions contributed to the Helicopter's left rotation described in 3.6.3.

(3) Psychological condition of the PIC

Regarding the PIC's hurrying to take control, because the PIC had another task to do after finishing the training and he demonstrated his desire to take control himself and return to the apron as quickly as possible, as was described in 2.1.2, it is somewhat likely that he put priority on operating the Hydraulic Cut Off switch after taking control and he neglected to pay attention to holding the flight controls.

### **3.7.2 Prevention of Similar Accident Occurrences**

In circumstances such as those seen in the accident, the following actions can, in general, be considered for preventing accidents.

- (1) As was described in 2.11.3 (3), the lock mechanism for the collective pitch lever is used when starting and stopping the engine and when inspecting the hydraulic system while the helicopter is parked. Because the lock is easily disengaged by pushing down slightly on the collective pitch lever, check that it is securely locked when using it while the rotor is rotating.
- (2) When transferring control, the helicopter can become unstable if the transfer of control is not clearly declared and one of the pilots does not securely hold the flight controls. Therefore, the side turning over control should continue holding the flight controls until the receiving side securely takes it, confirm the transfer, and then declare it.
- (3) Regarding restoration of the hydraulic system after hydraulic system failure training, hold the left collective pitch lever down in its lowest position without using the lock mechanism in order to ensure that the collective pitch lever is securely held as the right-seat pilot operates the Hydraulic Cut Off switch, and then confirm that the flight controls are in the neutral position while restoring the hydraulic system.

### **3.8 Training by HIRATA and Compliance with Rules and Regulations**

As was described in 3.6.2.1, it is considered probable that the PIC and Pilot A were conducting the hydraulic system failure procedure without accurately understanding it. Given this, when all HIRATA pilots who are qualified to fly the AS350 B3 (5 pilots) were asked about the hydraulic system failure training procedure, instances were found in which solid understanding and required knowledge of the cautions and notes provided in the emergency operating procedure and training procedure of the Flight Manual were not sufficiently established. Although each pilot was receiving education based on special training, it is probable that, with regard to subsequent changes in rules and regulations, the situation was such that materials were distributed via the in-house network and checked individually by pilots, and that differences in understanding emerged as a result. With regard to important changes, it is probable that opportunities must be available for people who have sufficiently acquired knowledge to provide education and to check that knowledge has been established, rather than leaving the matter to checking by individual pilots. Additionally, it is probable that confirming the intent of changes with the manufacturing company when it is unclear and sharing knowledge with all pilots are also necessary.

## 4. CONCLUSIONS

It is probable that this accident occurred because, when control was transferred from the pilot in the right seat to the PIC in the left seat immediately after the Helicopter made a running landing in hydraulic system failure training and the Helicopter attempted to lift off again, left rotation occurred and the Helicopter rolled over to the right due to dynamic rollover in which the trailing end of the right skid, which became stuck in the ground, served as the fulcrum, causing damage to the Helicopter.

Regarding the left rotation, it is probable that this occurred because the collective pitch lever rose after the transfer of control and appropriate control in response to it did not take place.

It is probable that the fact that an operation to restore hydraulic pressure was being conducted simultaneously with the transfer of control and the fact that the collective pitch lever was not being held appropriately contributed to the collective pitch lever's rise.

## 5. SAFETY ACTIONS

### 5.1 Safety Actions Taken by Hirata Gakuen

- (1) Terminated the crew service of the PIC and annual training pilot and conducted special training and special examinations.
- (2) Due to ambiguity in the transfer of flight controls, newly prepared and circulated “control transfer guidelines (transfer of flight controls).”
- (3) Provided education on the factors that cause dynamic rollover, and fully implemented reminders and prevention measures.
- (4) Because the accident occurred on a grass area, circulated guidelines for confirming the conditions of Grass Areas prior to conducting running landings and guidelines for taking off and landing on uneven surfaces.
- (5) To achieve standardization related to training and examinations, decided to conduct periodic discussions by pilots in charge of training and pilots in charge of skill examinations.
- (6) Due to frequent operations at temporary helipads, decided to make a use application that would permit annual training, etc., at temporary helipads.
- (7) In order to integrate training techniques, decided to have other pilots in charge of training observe training conditions in rear seats during annual training and annual examination.

# Appendix Figure 1 Three View of Drawings of Eurocopter AS350 B3

Unit: meter

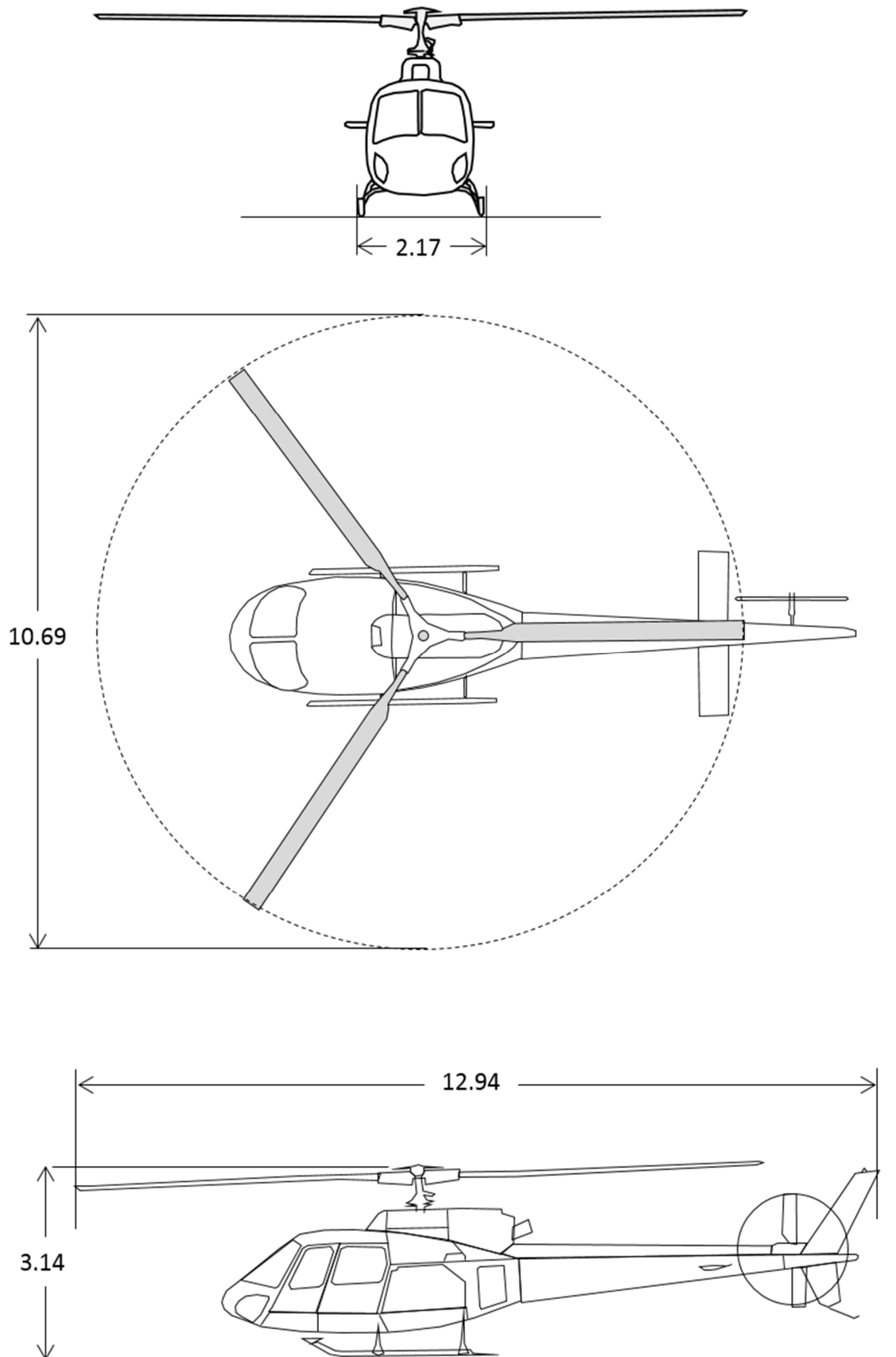

Appendix Figure 2 Hydraulic System of an AS350 B3

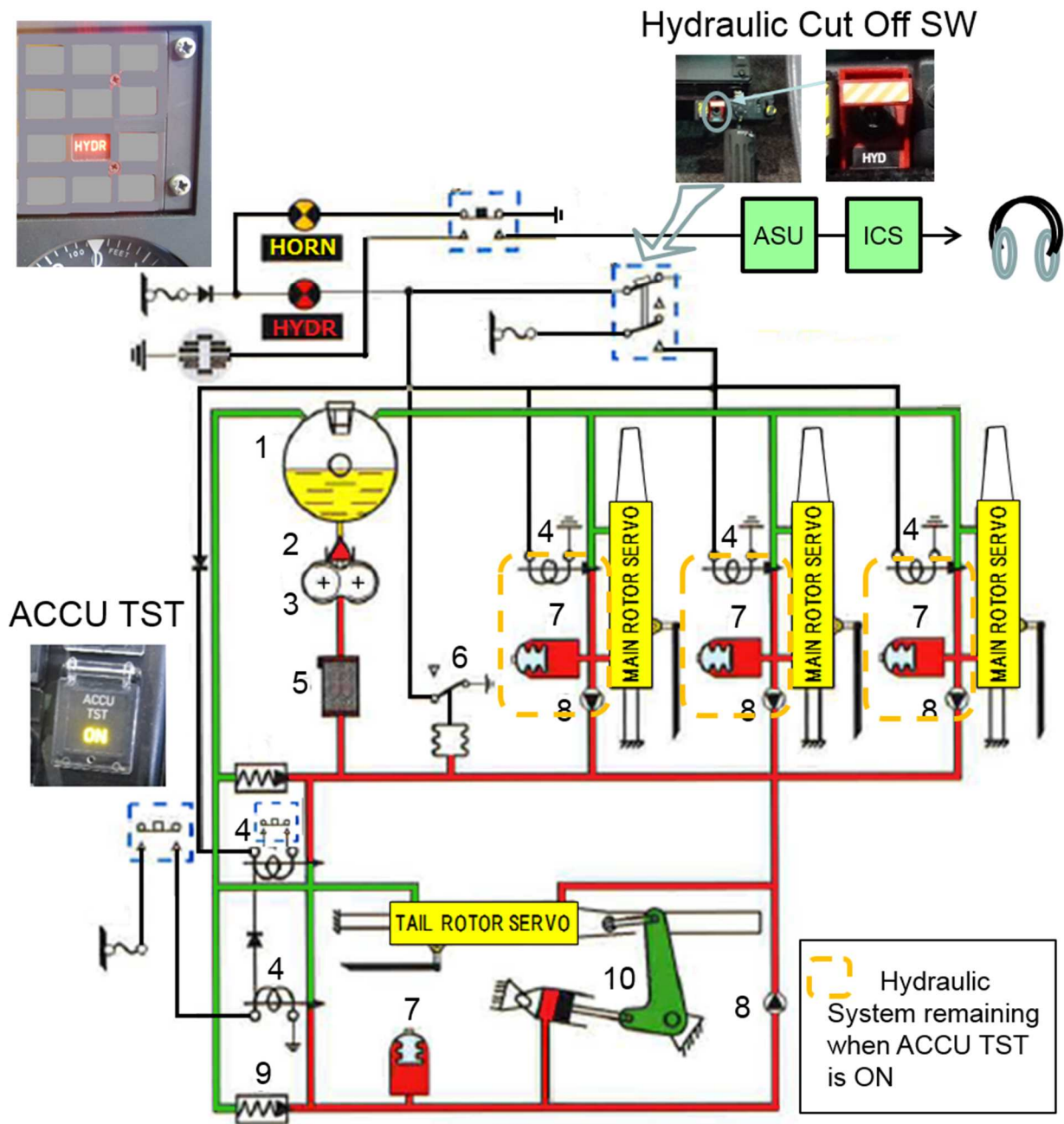

|   |                         |    |                           |
|---|-------------------------|----|---------------------------|
| 1 | Hydraulic fluid Tank    | 6  | Pressure switch           |
| 2 | Strainer                | 7  | Accumulators              |
| 3 | Pump                    | 8  | Non-return valve          |
| 4 | Solenoid electro-valves | 9  | Pressure regulating valve |
| 5 | Filter                  | 10 | Yaw Load compensator      |

### Appendix Figure 3 EDR Data

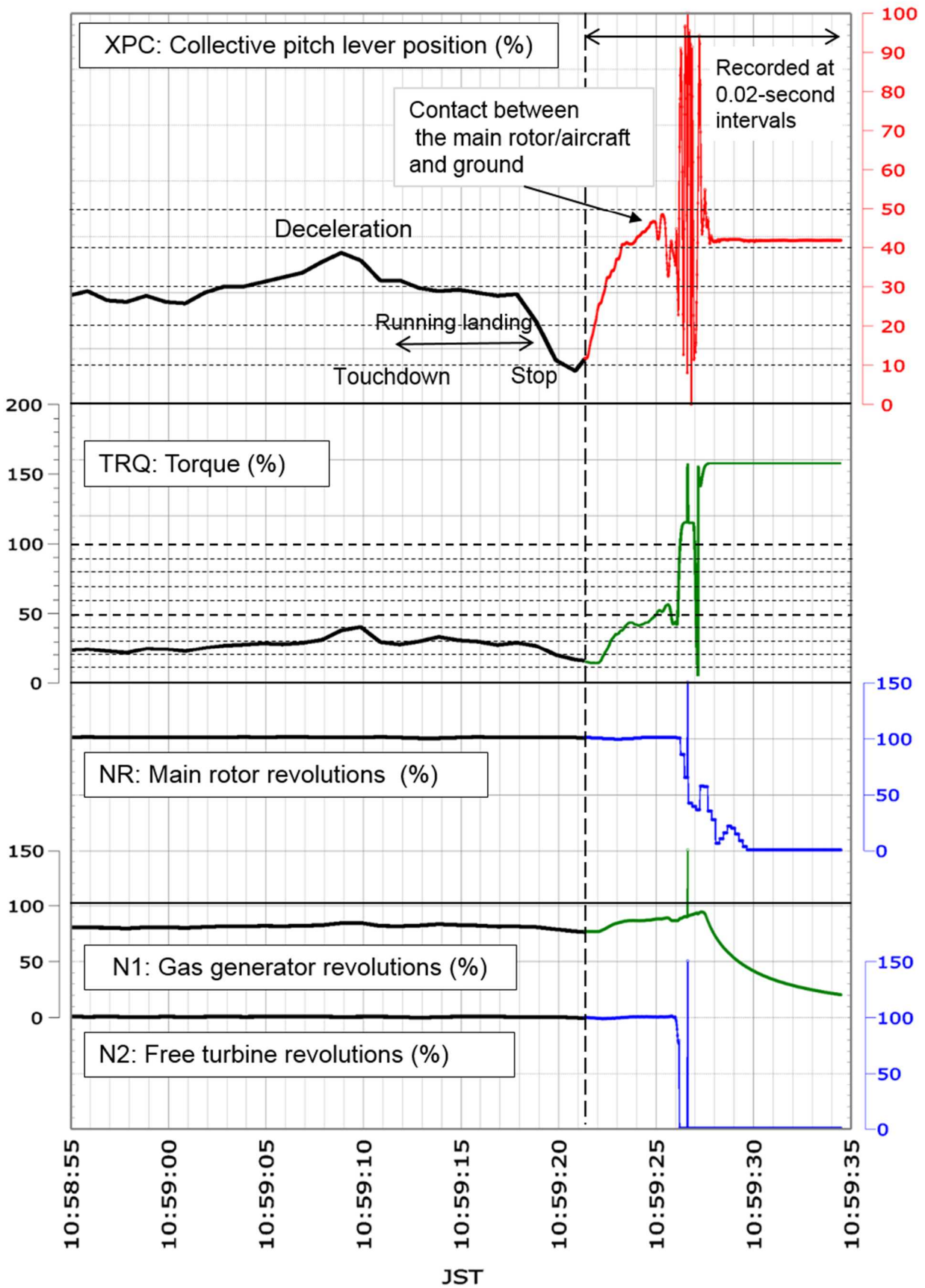

# Appendix 4 Estimated Flight Situation of the JA500H at the Time of the Accident

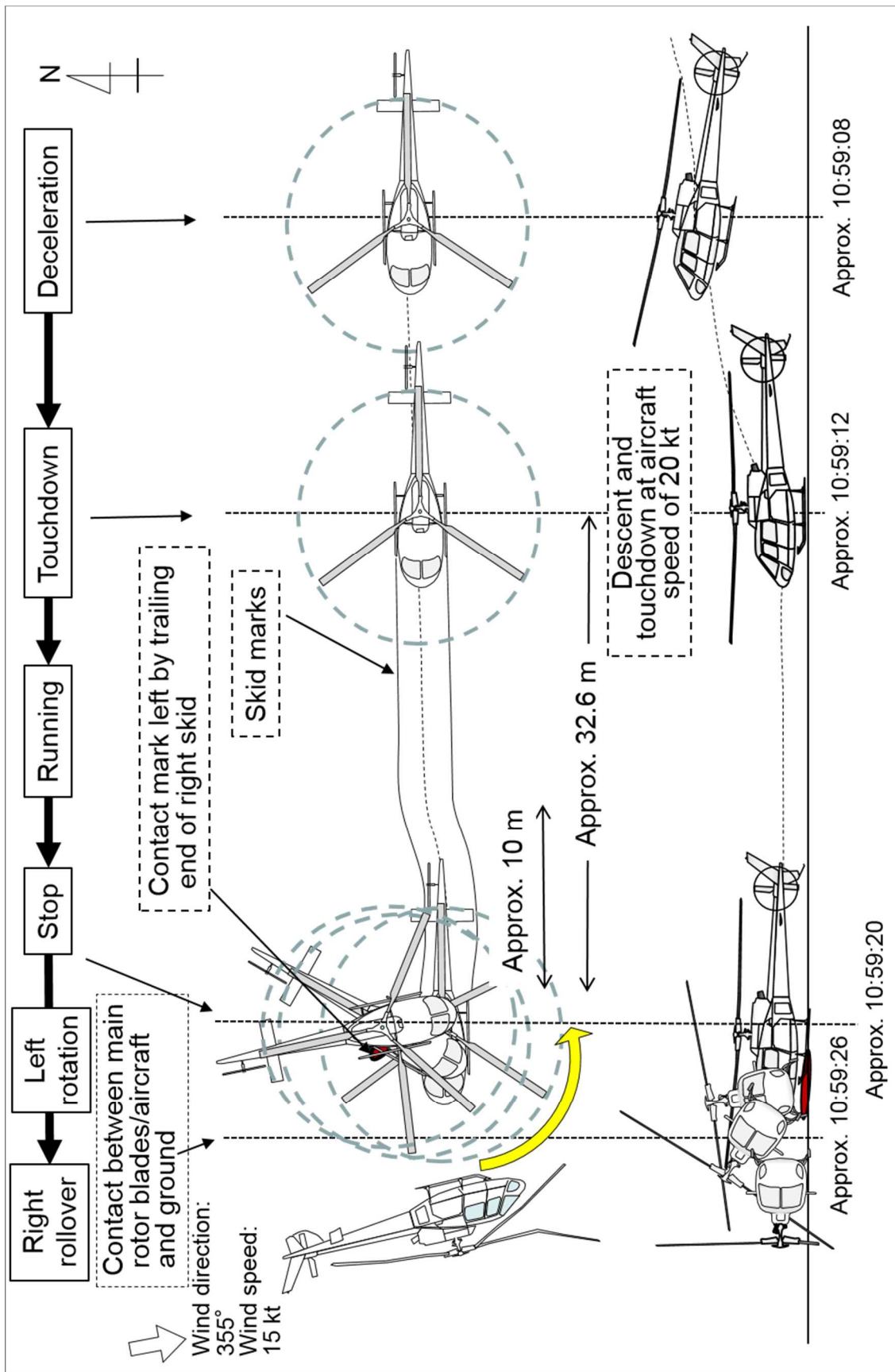



# Photo 2 Contact Marks at the Accident Site and Damage to the JA500H

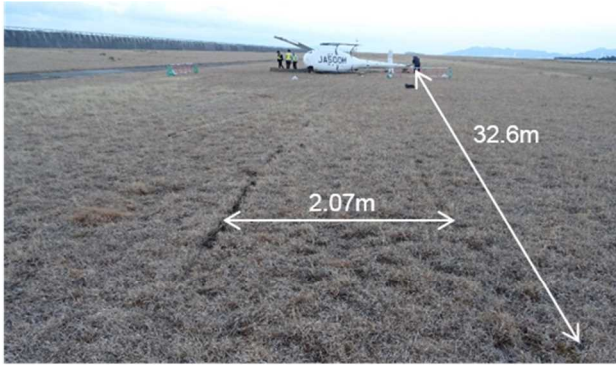

Contact marks from running landing viewed from east side

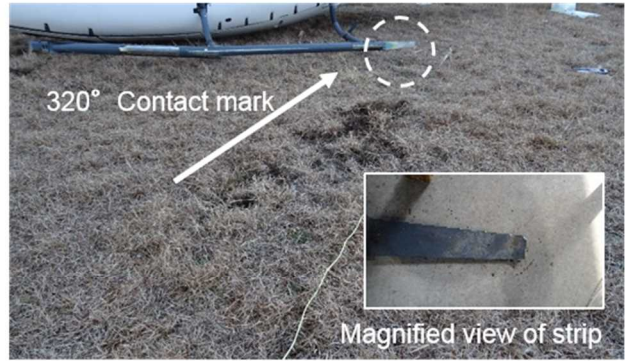

Contact mark made by trailing strip of right skid



Damage to aircraft seen from west side



Main rotor blade contact mark



Damage to top of fuselage

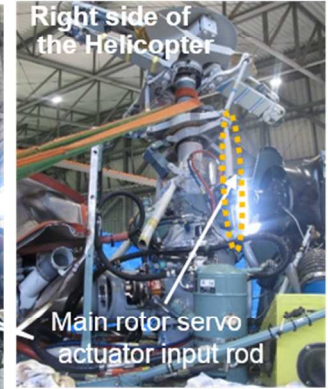

Damage to top of fuselage



Damage to the engine



Damage to the right side of the tail