

AA2015-4

**AIRCRAFT ACCIDENT  
INVESTIGATION REPORT**

**ANA WINGS CO., LTD.  
J A 4 6 2 A**

**April 23, 2015**

 **JTTSB** *Japan Transport Safety Board*

The objective of the investigation conducted by the Japan Transport Safety Board in accordance with the Act for Establishment of the Japan Transport Safety Board and with Annex 13 to the Convention on International Civil Aviation is to determine the causes of an accident and damage incidental to such an accident, thereby preventing future accidents and reducing damage. It is not the purpose of the investigation to apportion blame or liability.

Norihiro Goto  
Chairman,  
Japan Transport Safety Board

Note:

This report is a translation of the Japanese original investigation report. The text in Japanese shall prevail in the interpretation of the report.

# AIRCRAFT ACCIDENT INVESTIGATION REPORT

**DAMAGE CAUSED BY LIGHTNING STRIKE  
DURING LANDING APPROACH  
ANA WINGS CO., LTD.  
BOMBARDIER DHC-8-402, JA462A  
AT AN ALTITUDE OF APPROX. 5,300 FT, APPROX. 20 KM  
TO THE NORTHEAST OF FUKUE AIRPORT  
AT AROUND 09:30 JST, NOVEMBER 29, 2013**

April 10, 2015

Adopted by the Japan Transport Safety Board

Chairman	Norihiro Goto
Member	Shinsuke Endoh
Member	Toshiyuki Ishikawa
Member	Sadao Tamura
Member	Yuki Shuto
Member	Keiji Tanaka

## 1. PROCESS AND PROGRESS OF THE INVESTIGATION

On November 30, 2013, the Japan Transport Safety Board designated an investigator-in-charge and two investigators to investigate the accident. An accredited representative of Canada, as the State of Design and Manufacture of the aircraft involved in the accident, participated in the investigation.

Comments were invited from the parties relevant to the cause of the accident and from the relevant State.

## 2. FACTUAL INFORMATION

2.1 History of the Flight	<p>According to the statements of the Pilot in Command (PIC), First Officer (FO) and Operation controller as well as the records of the digital flight data recorder (DFDR), the history of the flight is summarized as follows.</p> <p>On November 29, 2013 at 09:03 Japan Standard Time (JST, UTC+9 hours), a Bombardier DHC-8-402, registered JA462A, operated by ANA Wings Co., Ltd. (hereinafter referred to as “the Company”), took off from Fukuoka Airport as flight 4915 of the Company bound for Fukue Airport, with the PIC, four other crew members, and 36 passengers, for a total of 41 people on board.</p> <p>In the pre-flight confirmation check of weather conditions, the PIC and the FO recognized that although on that day, when there was a wintry pressure pattern, a trough accompanied by cold air would pass through western Japan during the morning, there was no specific information indicating the possibility of lightning on the flight planned route of the aircraft. In the cockpit, the PIC sat in the left seat as the PF (pilot flying: pilot mainly in charge of flying), and the FO in the right seat as the PM (pilot monitoring: pilot mainly in charge of duties other than flying).</p> <p>While the aircraft was cruising at an altitude of 12,000 ft, heading for</p>
---------------------------	---

Fukue Airport, the PIC and the FO visually observed white clouds with a top height of 11,000 ft, on its course. When the aircraft began to descend at around 09:24 in order to approach the airport, the observed clouds were not so thick as could be suspected to cause turbulence or lightning but were displayed on the weather radar display of the aircraft in a green color, indicating an area with the weakest rainfall. At around 09:30, while descending through the clouds, the PIC and the FO observed a strong flash of light coming from the left fore side of the cockpit and heard a loud “bang” sound immediately after that.

Afterwards, the PIC and the FO carried out checks to determine if there were any abnormalities occurring with the aircraft while continuing its flight, and although a wind noise was heard from the nose direction, no other abnormalities were identified.

On the final approach to the airport, the aircraft exited the clouds, and then it landed at the airport at 09:37. Both the PIC and the FO did not notice any abnormalities when landing.

After landing, the PIC, the FO and the mechanic carried out inspections on the aircraft, and consequently, the following were revealed:

- Five dents occurred on the aft side outer skin of the upper left access panel on the nose,
- Six rivet heads on the upper left access panel on the nose were burned, and
- The aft latch of the upper right access panel on the nose, as well as the fore and aft latches of the upper left access panel on the nose were opened.

The Company inspected the details of the damage of the aircraft, and confirmed that deformations had also occurred on the internal structure supporting the rear side outer skin of the upper left access panel on the nose.

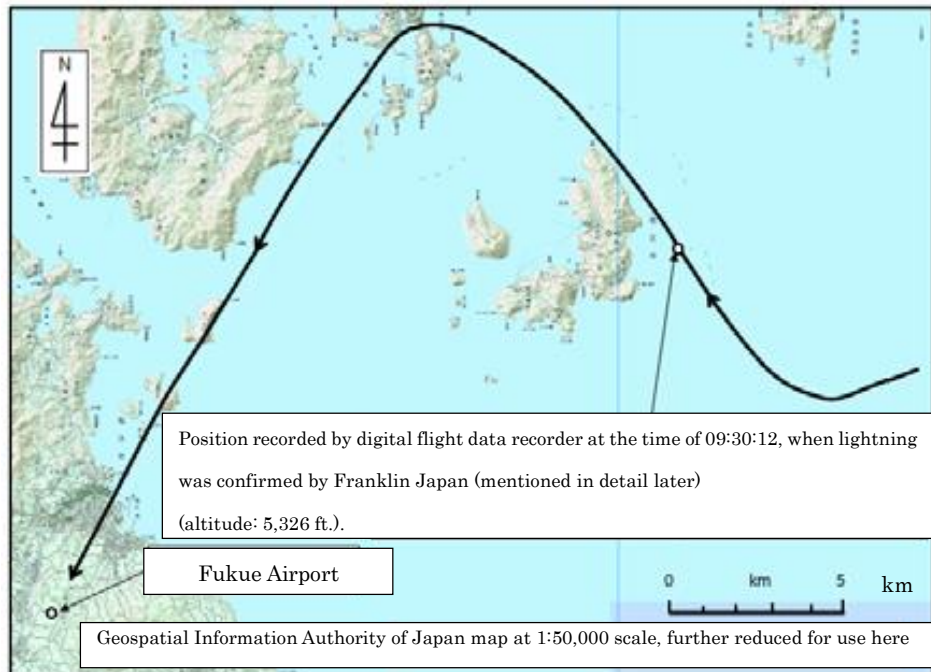

Estimated flight route of the aircraft

2.2 Injuries to Persons	None
2.3 Damage to Aircraft	<p>Extent of damage: Substantially damaged</p> <ul style="list-style-type: none"> <li>• Radome: Paint was flaked off approximately 1 mm diameter each in scattered areas.</li> <li>• Nose: Rivet heads (six) on the upper left access panel were</li> </ul>

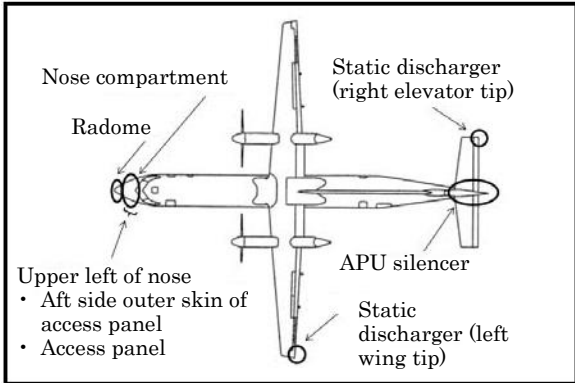
	<p>burned. Latches of the upper left and upper right access panels (three locations) were burned. Dents occurred in five locations on the aft side outer skin of the upper left access panel. (The depth of each dent was approximately one to three mm, and each dent was deformed toward the center of the dented surface. No other damage aside from deformation was revealed on the surfaces of the outer skin where the dents occurred.) Portions of the materials of the internal structure supporting the aft side outer skin where the dents occurred, of the upper left access panel, were deformed. (See Photo 2: Damage on Left Side of Nose)</p> <ul style="list-style-type: none"> <li>• Main wing: A static discharger was burned (left wing tip).</li> <li>• Elevator: A static discharger was burned (right hand elevator tip).</li> <li>• APU: Part of the silencer was burned.</li> </ul>  <p style="text-align: center;">Major damaged areas of the aircraft</p>
2.4 Personnel Information	<p>(1) PIC Male, Age 54 Airline transport pilot certificate (Airplane) November 14, 2005 Type rating for Bombardier DHC-8 November 14, 2005 Class 1 aviation medical certificate Validity: Until May 29, 2014 Total flight time 18,759 hours 10 minutes Total flight time on the type of airplane 9,637 hours 10 minutes</p> <p>(2) FO Male, Age 37 Commercial pilot certificate (Airplane) May 21, 2009 Type rating for Bombardier DHC-8 August 20, 2012 Instrument flight certificate (Airplane) February 16, 2010 Class 1 aviation medical certificate Validity: Until February 7, 2014 Total flight time 1,103 hours 36 minutes Total flight time on the type of airplane 690 hours 29 minutes</p>
2.5 Aircraft Information	<p>(1) Type: Bombardier DHC-8-402 Serial number: 4445, Date of manufacture: June 21, 2013 Certificate of airworthiness: No. TO-25-166 Validity: During a period in which the aircraft is maintained in accordance with the Maintenance Management Manual Category of airworthiness: Aeroplane, Transport T Total flight time: 811 hours 29 minutes</p> <p>(2) The aircraft was equipped with a digital flight data recorder (DFDR) and a cockpit voice recorder (CVR). The DFDR recorded no shock, vibration, or any other malfunction associated with the accident. The CVR did not contain any voice records during the flight since they had been overwritten.</p> <p>(3) It is estimated that both the weight and the center of gravity were</p>

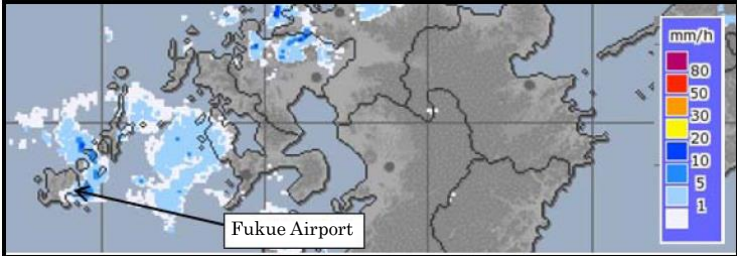
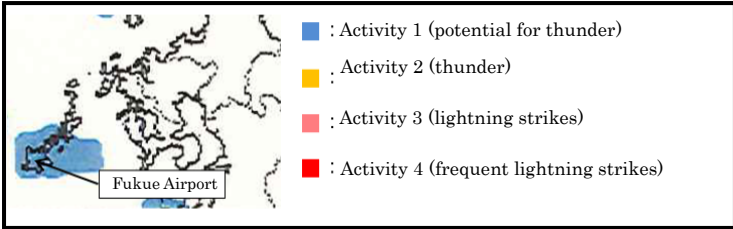
	<p>within the allowable range when the accident occurred.</p> <p>(1) The Aviation Special Weather Report for Fukue Airport during the time period of the aircraft's approach was as follows.  09:28 Wind direction and velocity: 280°, 12 kt  Wind direction variation: between 250° and 320°  Prevailing visibility: 10 km or more; Weather: sleet  Cloud amount: 1/8; cumulus; cloud base: 1,500 ft.  Cloud amount: 4/8; cumulus; cloud base: 2,500 ft.  Cloud amount: 6/8; cumulus; cloud base: 3,000 ft.  Temperature: 6°C; Dew point: 3°C  Altimeter setting (QNH): 30.13 inHg</p> <p>(2) The meteorological conditions near Fukue Airport were as follows.  It was a wintry pressure pattern in which a high pressure area is to the west and a low pressure area is to the east; besides, the atmospheric condition was unstable with cold at the same level as the depth of winter due to the passage of a pressure trough with cold air.</p>  <p>Precipitation Radar Image by Japan Meteorological Agency (as of 09:20, November 29)</p>  <p>Thunder Nowcast by Japan Meteorological Agency (as of 09:20, November 29)</p> <p>(3) Observation of lightning according to Franklin Japan  Franklin Japan is a company that provides meteorological information, primarily focusing on lightning and carrying out observation of the occurrence of lightning strikes, with lightning sensors placed at 30 locations within Japan. One lightning strike was observed by Franklin Japan at 09:30:12 near the flight route of the aircraft, according to observation made on the day of the accident from 09:15 to 09:45.</p>
<p>2.7 Additional Information</p>	<p>The fore and aft latches of the upper left access panel on the nose, and the aft latch of the upper right access panel on the nose, were opened.  Even if the fore and aft latches of the upper left and upper right access panels on the nose are opened, their structure is such that other mechanisms will prevent those panels from becoming fully released. Although there is a pitot tube each located to the aft of the upper left and upper right access panels on the nose for detection of speed and other factors, there were no abnormalities identified with any data indicated by flight instruments, according to the DFDR records and the statements of the PIC and the FO.</p>

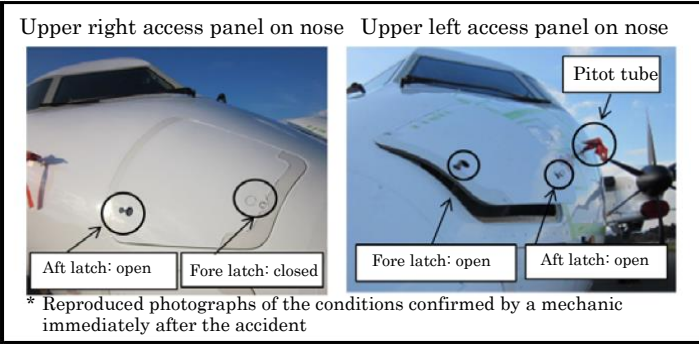
	 <p style="text-align: center;">Condition of upper left and upper right access panels on the nose after the accident</p>
--	--

### 3. ANALYSIS

3.1 Involvement of Weather	Yes
3.2 Involvement of Pilots	None
3.3 Involvement of Aircraft	None
3.4 Analysis of the Findings	<p>(1) Time and location of lightning strike</p> <p>According to the statements of the PIC and the FO, it is highly probable that around 09:30, while on approach to Fukue Airport, the aircraft was struck by lightning at approximately 20 km to the northeast of the airport, at an altitude of approximately 5,300 ft.</p> <p>(2) Involvement of weather</p> <p>From observed weather information, the meteorological conditions around the airport on the day of the accident consisted of a wintry pressure pattern in which a high pressure area was to the west and a low pressure area was to the east; besides, it was cold at the same level as the depth of winter due to the passage of a pressure trough with cold air. Therefore, it is highly probable that charged low-altitude cumulus clouds were distributed over a wide area on the flight route of the aircraft.</p> <p>It is highly probable that the lightning strike that caused damage to the aircraft was not from cumulonimbus clouds that often appear locally in the summer season but from cumulus clouds distributed over a wide area at a low altitude that often appear on the Sea of Japan side in the winter season. Although the PIC and the FO visually observed the cumuli clouds distributed over a wide area on the flight route to the airport and recognized that they were displayed as a weakest rainfall area on the weather radar display of the aircraft, it is probable that it was difficult to predict lightning strikes within those clouds distributed over a wide area, and that selection of a flight route to avoid those cumuli clouds was not a realistic option.</p> <p>(3) Cause of damage</p> <p>It is probable that the dents that occurred in five locations on the aft side outer skin of the upper left access panel on the nose of the aircraft and the deformation also occurring to portions of the internal structure supporting the outer skin were caused by being subjected to strong air pressure from the vicinity around the nose section since the surface of each of those five locations on the outer skin was depressed uniformly toward the center and since no damage other than deformation was revealed on the surface. Because of the multiple scattered areas where paint was flaked off on and around the radome,</p>

	<p>revealed as multiple traces left by a lightning strike, it is probable that this strong air pressure was generated by an extremely powerful shockwave caused on rare occasions by the discharge of lightning. It is probable that this shockwave was of the same type as an infrequently-reported case where lightning strikes to structures on the ground cause a discharge of lightning that results in a very rapid expansion of air that exceeds the speed of sound in air, generating a shockwave known to shatter the window glass of buildings surrounding the lightning strike.</p> <p>Since the burns revealed on the areas from the radome of the aircraft to its tail sections and wing tip are signs of electrical damage generally seen after lightning strikes, it is probable that they were caused when the aircraft was struck by lightning and that a conductive path for the lightning current was formed from the radome to the wing tip, APU silencer, and other components.</p> <p>(4) Cause of the opened latches of the upper left and upper right access panels on the nose</p> <p>It is somewhat likely that the fore and aft latches of the upper left access panel on the nose were opened because an extremely powerful shockwave caused on rare occasions by the discharge of lightning was generated and acted on the latch knobs in such a way in order to push them inward. It is somewhat likely that the aft latch of the upper right access panel on the nose was opened because this shockwave acted on the latch knob in such a way as to push it inward or because when the fore and aft latches of the upper left access panel on the nose were opened, the internal air pressure of the nose compartment abruptly decreased, causing the latch knob to be pulled inward; however, it was impossible to reveal the details.</p>
--	--

**4. PROBABLE CAUSES**

In the accident, it is somewhat likely that the aircraft sustained damage on the aft side outer skin of the upper left access panel on the nose and on the portions of the internal structure supporting the outer skin because it was subjected to a powerful shockwave generated by the discharge of lightning while making a landing approach.

- Figure: Three Angle View of Bombardier DHC-8-402
- Photo 1: Aircraft Involved in the Accident
- Photo 2: Damage on Left Side of Nose



Figure 1: Three Angle View of Bombardier DHC-8-402

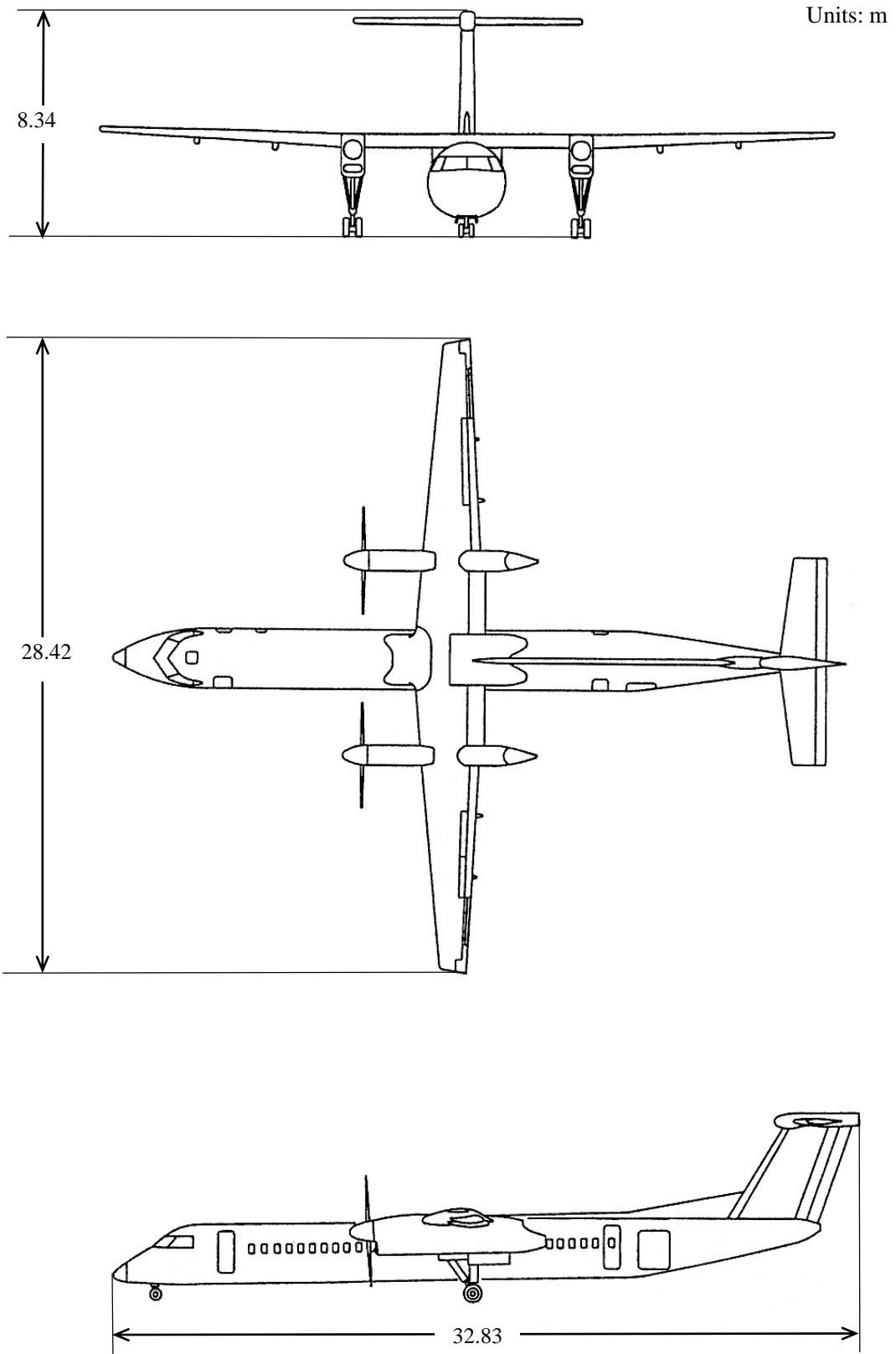
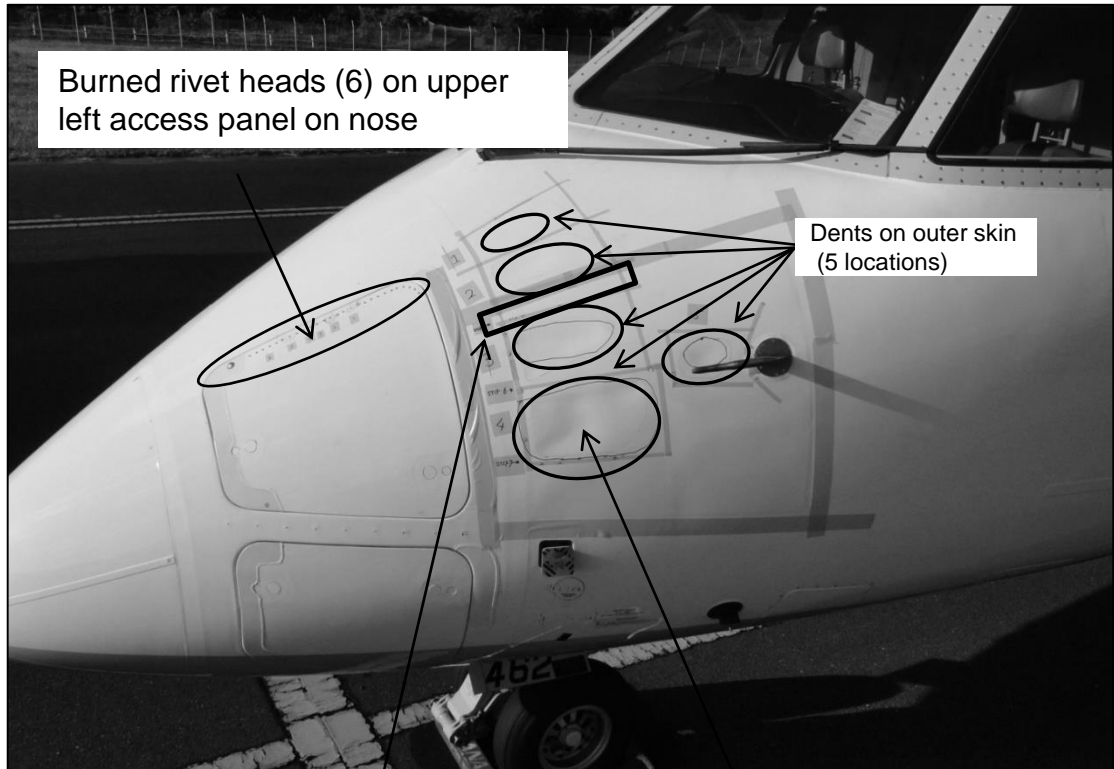

Photo 1: Aircraft Involved in the Accident



## Photo 2: Damage on Left Side of Nose



Enlarged Photo  
(taken from the interior of the aircraft)

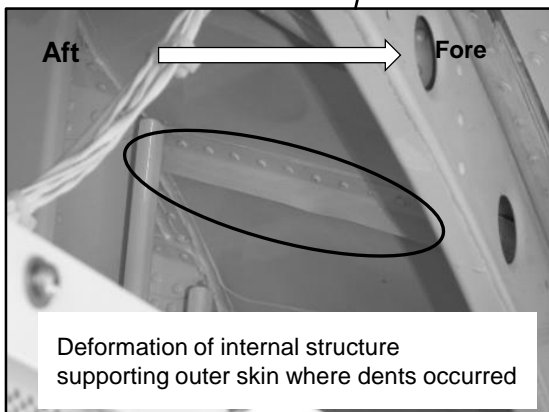

Enlarged Photo

