

AA2010-3

**AIRCRAFT ACCIDENT  
INVESTIGATION REPORT**

**PRIVATELY OWNED**

**J A 4 1 0 6**

**March 26, 2010**

**Japan Transport Safety Board**

The investigation for this report was conducted by Japan Transport Safety Board, JTSCB, about the aircraft accident of Privately Owned, Socata TB10, registration JA4106 in accordance with the Act for the Establishment of the Japan Transport Safety Board and Annex 13 to the Convention on International Civil Aviation for the purpose of determining causes of the aircraft accident and contributing to the prevention of accidents/incidents and not for the purpose of blaming responsibility of the accident.

This English version of this report has been published and translated by JTSCB to make its reading easier for English speaking people who are not familiar with Japanese. Although efforts are made to translate as accurately as possible, only the Japanese version is authentic. If there is any difference in the meaning of the texts between the Japanese and English versions, the text in the Japanese version prevails.

Norihiro Goto,  
Chairman,  
Japan Transport Safety Board

# **AIRCRAFT ACCIDENT INVESTIGATION REPORT**

**PRIVATELY OWNED SOCATA TB10, JA4106  
IN THE SEA, ABOUT 200 METERS EAST  
OF RUNWAY B, NAGASAKI AIRPORT,  
AT ABOUT 17:23 JST, JULY 26, 2008**

February 17, 2010

Adopted by the Japan Transport Safety Board (Aircraft Sub-committee)

|          |                |
|----------|----------------|
| Chairman | Norihiro Goto  |
| Member   | Yukio Kusuki   |
| Member   | Shinsuke Endo  |
| Member   | Noboru Toyooka |
| Member   | Yuki Shuto     |
| Member   | Akiko Matsuo   |

# **1. PROCESS AND PROGRESS OF THE AIRCRAFT ACCIDENT INVESTIGATION**

## **1.1 Summary of the Accident**

On July 26 (Saturday), 2008, a privately owned Socata TB10, registered JA4106, took off from Runway B (32) of Nagasaki Airport on a familiarization flight. When the pilot detected a strange odor and saw white smoke entering the cockpit during the climb following takeoff, he immediately attempted to re-land on Runway B (32), but the aircraft ditched in the sea about 200 m east of Runway B of the airport at about 17:23 Japan Standard Time (JST: unless otherwise stated, all times are indicated in JST).

There were three pilots on board: the Captain and two other pilots. One died, another was seriously injured, and the third was slightly injured. The aircraft was destroyed.

## **1.2 Outline of the Accident Investigation**

### **1.2.1 Investigation Organization**

On July 26, 2008, the Aircraft and Railway Accidents investigation Commission (ARAIC) designated an investigator-in-charge and two other investigators to investigate this accident.

### **1.2.2 Representative from Foreign Authorities**

An accredited representative of France, as the State of Design and Manufacture of the aircraft involved in this accident, participated in the investigation.

### **1.2.3 Implementation of the Investigation**

|                    |                                  |
|--------------------|----------------------------------|
| July 27 – 31, 2008 | Airframe examination; interviews |
| October 16, 2008   | Interviews                       |

### **1.2.4 Interim Report**

On August 28, 2009, the JTSB submitted an interim report to the Minister of Land, Infrastructure, Transport and Tourism based on the facts found up to that date, and the report was made available to the public.

### **1.2.5 Comments from Parties Relevant to the Cause of the Accident**

Comments were invited from parties relevant to the cause of the accident.

### **1.2.6 Comments from the Participating State**

Comments were invited from the participating State.

## 2. FACTUAL INFORMATION

### 2.1 History of the Flight

On July 26, 2008, a privately owned Socata TB10, registered JA4106 (hereinafter referred to as “the Aircraft”), took off from Saga Airport at 15:38 on the outward journey of a planned round-trip familiarization flight between Saga Airport and Nagasaki Airport with the Captain and two other pilots on board. The Aircraft landed at Nagasaki Airport at 16:02.

The flight plan for the homeward journey from Nagasaki Airport to Saga Airport submitted to the Nagasaki Airport Office of the Osaka Regional Civil Aviation Bureau is outlined below:

|                                   |                                     |
|-----------------------------------|-------------------------------------|
| Flight rules:                     | Visual flight rules (VFR)           |
| Departure aerodrome:              | Nagasaki Airport                    |
| Estimated off-block time:         | 17:15                               |
| Cruising speed:                   | 110 kt                              |
| Cruising altitude:                | VFR                                 |
| Route:                            | Takezaki (position reporting point) |
| Destination aerodrome:            | Saga Airport                        |
| Total estimated elapsed time:     | 0 h 30 min                          |
| Fuel load expressed in endurance: | 4 h 30 min                          |
| Persons on board:                 | 3                                   |

The history of the flight up to the time of the accident is summarized below, based on the ATC communications records, the ATC radar records, and the statements of the Captain, the pilot who was seriously injured (hereinafter referred to as “Pilot A”) and the air traffic controllers (hereinafter referred to as “the Controllers”) at the Nagasaki Airport Office.

The Aircraft was cleared for takeoff at 17:20’00”, then it started a takeoff roll and took off from Runway 32 at 17:21. After lift-off, the Aircraft began a right turn to leave the runway and, at 17:22’00”, contacted the Controllers to request clearance for landing via the right downwind leg. The Controller cleared the Aircraft at 17:22’30” to land on Runway 32. Subsequently, although the Aircraft once entered the right downwind leg, it made a right turn and ditched in Omura Bay.

#### (1) Captain

I arrived at Saga Airport before 3 o’clock in the afternoon. The two other pilots had already completed the pre-flight inspection as stipulated in the flight manual. I conducted a weather briefing, confirmed the planned round-trip flight to and from Nagasaki Airport, and carried out the pre-departure test run of the engine. During the flight to Nagasaki Airport, I sat in the left front seat, Pilot A sat in a rear passenger seat, and the other pilot (hereinafter referred to as “Pilot B”) sat in the right front seat; the Aircraft was flown under my control via Takezaki, and landed at Nagasaki Airport at 16:02.

After taking a break at Nagasaki Airport for nearly an hour, Pilot A and I conducted the

pre-flight inspection in preparation for the flight back to Saga Airport and then the engine test run was carried out while I was sitting in a rear passenger seat, Pilot A in the left front seat and Pilot B in the right front seat. Piloted by Pilot A, the Aircraft began its departure from Runway 32. The takeoff roll involved nothing unusual and the Aircraft lifted off about halfway along the runway, but around the time when the Aircraft began making a right turn, I smelled an odor in the cockpit similar to burning plastic and I saw a thin stream of brownish-white smoke entering the cockpit through the left air vent at the pilot seats. Pilot B then took over the Aircraft controls and made a request to the Controllers for clearance to return and land. After entering the traffic pattern, when the throttle was opened I think, a large amount of smoke blasted into the cockpit, which made me feel that something serious was happening. At about that time, the Aircraft began descending and then Pilot B started using the controls to turn right again. When the Aircraft was about to ditch in the water, its longitudinal axis was almost parallel with the runway and the Aircraft was slightly banked to the right. Water poured into the cockpit as soon as the Aircraft ditched in the water, and the Aircraft immediately began sinking. I groped around under the water for an escape exit, and when I reached the water surface, I saw Pilot B first and then Pilot A, who appeared above the water surface some while later. Pilot B spoke to me, saying, "Let's swim over to there," but I said, "No. It's impossible for me." I was exhausted just from escaping out of the Aircraft and I am not a good swimmer, so I held on to nearby floating wreckage and decided to wait for rescue. I did not see what happened to the other pilots after this.

I found nothing abnormal during either the pre-flight inspections or engine test runs at both airports and I heard no abnormal engine sounds after the takeoff from Nagasaki Airport, but I felt that the Aircraft's speed was rather slow during the climb and turn. The propeller continued rotating up until we ditched, although I felt that the engine was not delivering the necessary power.

We belonged to a flying club of five people, and Pilot B was always the pillar of our flying club. The Aircraft had a reserved parking spot at Saga Airport. Regular periodic maintenance as well as servicing for any problems was handled by a contracting maintenance company that has an office at the airport. Therefore, what the club members had to do on a daily basis was a simple routine inspection, including cleaning and engine oil replenishment, but not inspections that required removal of the engine cowlings (hereafter referred to as "the Cowlings"). We had never experienced anything abnormal with the Aircraft.

(2) Pilot A

After arriving at Saga Airport, I carried out the pre-flight inspection of the Aircraft for each item that Pilot B read aloud. Together we checked the weather and confirmed the planned flight to Nagasaki Airport, after which the Aircraft took off from Saga Airport piloted by the Captain.

Before departing from Nagasaki Airport, I carried out the engine test run according to the check items read aloud by the Captain. After confirming that there was no problem with the Aircraft, the Aircraft took off from Runway 32 under my control.

Just after the lift-off at a point for which I do not remember the location, following a normal takeoff roll, smoke that smelled like burning plastic entered the cockpit, so Pilot B immediately took over the control wheel to pilot the Aircraft in my place. After contacting the Controllers to request clearance for landing, Pilot B made the Aircraft enter the traffic pattern. I think the altitude then was about 250 ft. After this, smoke poured in from the left air vent at the pilot seats. Pilot B made a right turn, saying, "We are going to ditch." I think he successfully kept control of the Aircraft up to the time of ditching.

While the Aircraft began sinking soon after ditching, I managed to get to the surface of the water. When I looked around, I saw that the other two pilots were already above the water surface. Pilot B began swimming toward the seawall on which the runway ran, saying, "Let's swim over to there." I followed him, but after swimming 7 or 8 m, I returned and held on to nearby wreckage and waited to be rescued while slowly swimming to shore. About 50 to 70 m from the shore, I was saved by a rescuer who swam over carrying a tethered life buoy. I think I swam for about 30 minutes before being rescued.

After the takeoff, there was no abnormal noise or vibration, and both the engine and propeller kept rotating until the ditching. The smoke blew aft past the cockpit without pervading the interior, so it was not so dense as to block our forward view.

(3) Controller (tower controller)

I cleared the Aircraft for takeoff from Runway 32. The Aircraft took off at about 17:21. After lifting off at a point near Taxiway T-3, the Aircraft began turning right while climbing. Soon after starting the turn, the pilot contacted us, requesting clearance to land while adding that he intended to enter the right downwind leg for Runway 32; I then issued clearance to land. From about the time that the Aircraft entered the right downwind leg, it became possible for me to see streaks of smoke emanating from the rear of the Aircraft. When the Aircraft began turning to the right after flying the right downwind leg for a short time, the left side of the Aircraft's nose became visible, and I saw a round mass of orange flames that looked like a setting sun. Then, the Aircraft went down as if it were on a slope before ditching. After the ditching, I could see through binoculars that persons were swimming in the water.

There was no report from the Aircraft announcing an emergency situation, so until I saw the smoke I did not think that the Aircraft was in a state where ditching was unavoidable.

(4) Controller (ground controller)

I do not remember exactly where the Aircraft lifted off. When the Aircraft made a right turn after takeoff, there was contact from the Aircraft, requesting clearance for landing. I looked at the Aircraft, which was about to enter the right downwind leg for Runway 32. While watching the Aircraft and thinking that some type of problem had arisen, I saw streaks of black smoke behind the Aircraft. I made emergency calls about the situation to the Nagasaki Airport Office of the Air Safety Foundation (hereinafter referred to as "the Air Safety Foundation") and the Air Traffic Services Information Officer at the Nagasaki Airport Office of the Osaka Regional Civil Aviation Bureau (hereinafter referred to as "the Information Officer"). Despite my expectations that the Aircraft would be able to land on

the runway, it began a right turn and then ditched in the water. I reported this (at about 17:23) to both the Air Safety Foundation and the Information Officer, and also requested Fleet Air Wing 22 of the Japan Maritime Self-Defense Force (hereinafter referred to as “the JMSDF Fleet Air Wing”) to dispatch rescue vessels.

The accident occurred at about 17:23 in the sea about 200 m east of Runway B of Nagasaki Airport (Latitude 32°55'06"N, Longitude 129°54'01"E).

(See Figure 1 Estimated Flight Route)

## **2.2 Deceased and Injuries to Persons**

Pilot B died. Pilot A was seriously injured. The Captain was slightly injured.

## **2.3 Damage to the Aircraft**

### **2.3.1 Extent of Damage**

The Aircraft was destroyed.

### **2.3.2 Damage to the Aircraft Components**

The Aircraft was salvaged from the seabed where it had lain following ditching, after which inspection was conducted at Nagasaki Airport. The condition of the damage to the Aircraft’s components found as a result of inspection is described below.

- |                |  |
|----------------|--|
| (1) Right wing | Torn off at the wing root; wing tip damaged                |
| Left wing      | Wing tip damaged   |
| (2) Cowlings   | Left side: Broken off and burned                           |
| (3) Engine     | LH <sup>*1</sup> front manifold detached from exhaust pipe |
| (4) Hoses      | Burned out   |
| (5) Windshield | Broken   |

### **2.3.3 Readings of the Main Instruments and Indicators, and Positions of the Engine Control Levers, etc.**

The positions of the switches and levers were as follows. There were no instruments that showed the conditions associated with the time of occurrence of the accident.

- |                         |           |
|-------------------------|-----------|
| (1) Ignition switch     | Both      |
| (2) Fuel selector lever | Right     |
| (3) Booster pump        | On        |
| (4) Pitch trim          | Take off  |
| (5) Flap control lever  | Take off  |
| (6) Throttle lever      | Full open |

---

<sup>\*1</sup> LH stands for the left-hand side and RH for the right-hand side when viewed looking towards the nose from the pilot seats.



- |                                   |           |
|-----------------------------------|-----------|
| (7) Mixture lever                 | Full rich |
| (8) Propeller control lever       | Low pitch |
| (9) Carburetor heat control lever | Cold      |

(See Photo 1 Accident Aircraft, Photo 2 Lower Left Area of the Burned Engine, Photo 3 Burned Areas of the Cowlings (External Surface, Internal Surface), Photo 5 Positions of the Control Levers, Photo 6 LH Side of the Exhaust Pipe, and Photo 7 Fracture Surface of the Connecting Pipe)

## 2.4 Personnel Information

- |  |                                     |
|--|-------------------------------------|
| (1) Captain, Male, Age 59                  |                                     |
| Private Pilot Certificate (Airplane)       | June 26, 1984                       |
| Type rating for single engine (land)       | June 26, 1984                       |
| Class 2 Aviation Medical Certificate       |                                     |
| Validity                                   | Until October 4, 2008               |
| Total flight time                          | 264 h 13 min                        |
| Flight time in the last 30 days            | 0 h 25 min                          |
| Total flight time on this type of aircraft | 111 h 58 min                        |
| Flight time in the last 30 days            | 0 h 25 min                          |
| (2) Pilot A, Male, Age 65                  |                                     |
| Private Pilot Certificate (Airplane)       | January 25, 1999                    |
| Type rating for single engine (land)       | January 25, 1999                    |
| Class 2 Aviation Medical Certificate       | Not obtained (Expired)              |
| Total flight time                          | N/A (document lost in the accident) |
| Flight time in the last 30 days            | N/A (document lost in the accident) |
| Total flight time on this type of aircraft | N/A (document lost in the accident) |
| Flight time in the last 30 days            | N/A (document lost in the accident) |
| (3) Pilot B, Male, Age 55                  |                                     |
| Commercial Pilot Certificate (Airplane)    | December 14, 1976                   |
| Type rating for single engine (land)       | December 14, 1976                   |
| Class 1 Aviation Medical Certificate       | Not obtained (Expired)              |
| Total flight time                          | N/A (records not found after death) |
| Flight time in the last 30 days            | N/A (records not found after death) |
| Total flight time on this type of aircraft | N/A (records not found after death) |
| Flight time in the last 30 days            | N/A (records not found after death) |

## 2.5 Aircraft Information

### 2.5.1 Aircraft

|                              |                  |
|------------------------------|------------------|
| Type                         | Socata TB10      |
| Serial number                | 943              |
| Date of manufacture          | November 2, 1989 |
| Certificate of airworthiness | DAI 19-385       |

|   |                            |
|---|----------------------------|
| Validity  | Until September 27, 2008   |
| Category of airworthiness   | Airplane, Utility category |
| Total flight time   | 1,556 h 05 min             |
| Flight time since last periodical check<br>(100-hour check on September 28, 2007) | 47 h 15 min                |

### 2.5.2 Engine

|  |                    |
|--|--------------------|
| Type   | Lycoming O-360A1AD |
| Serial number  | L-31407-36A        |
| Date of manufacture  | May 22, 1986       |
| Total time in service  | 1,556 h 05 min     |
| Flight time since last periodical check<br>(100-hour check on September 28, 2007)<br>(See Figure 3 Three Angle Views of Socata TB10) | 47 h 15 min        |

### 2.5.3 Maintenance of the Aircraft

According to the statements of the two maintenance engineers (hereinafter referred to as “Mechanic A” and “Mechanic B”) of the company that undertook the 100-hour and 50-hour checks of the Aircraft (hereinafter referred to as “the Company”) within the 12-month period prior to the accident, Mechanic A conducted the 100-hour check and the confirmation after completion of the 50-hour check, while Mechanic B conducted the 50-hour check. These checks are as outlined below.

- (1) Mechanic A conducted the 100-hour check on the Aircraft as per the maintenance manual (4A INSPECTION – 100 HOURS and ANNUAL INSPECTION (AI)) and the confirmation after the completed 50-hour check (2A INSPECTION – 50 HOURS and the 50-hour check sheet).

Mechanic A conducted the 100-hour check on the exhaust system, by removing the heat exchanger, exhaust pipe, fitting tubes, hoses, clamps and other related components, and then carrying out visual inspections on the heat exchanger and exhaust pipe, paying particular attention to cracks, missing materials, loose clamp screws, cracks in welds, wear in manifold ears, etc. The check found nothing abnormal. The inside of the exhaust manifolds and the exhaust pipe are exposed to exhaust gases under high pressure; if these components have any cracks, exhaust gases can leak out, leaving deposits of a grayish-white substance <sup>\*2</sup> on areas surrounding the cracks. Being aware of this, Mechanic A performed the inspection paying attention to such deposits but did not find any indication of their presence. It was a routine practice to clean the Cowlings with neutral detergent whenever they were removed, so any apparent abnormal condition on the inside or outside should have been found, but Mechanic A did not find anything abnormal there.

---

<sup>\*2</sup> Grayish-white deposits originate from the lead contained in the fuel. When the lead is discharged from the engine together with combustion gases and if there are cracks in the exhaust piping, etc., it leaks out through the cracks and is blown around forming grayish-white deposits on areas around the cracks.

After the check was finished, the engine was run and an external visual inspection was performed, checking for light-gray deposits and loose clamp screws; screws were tightened if loose.

The maintenance manual specifies a visual inspection for the 50-hour check with the components in the assembled state. However, since the 50-hour check sheet included the inspection of the heat exchanger that required its removal, it was a routine practice for the maintenance engineers to perform the inspection with the clamps and other relevant parts removed. Mechanic A received a report from Mechanic B, who conducted the 50-hour check, that there were no abnormalities found during this inspection.

No work sheets were produced for either of these checks, so there were no available records that included measurements.

- (2) Mechanic B conducted the 50-hour check according to both the maintenance manual and the 50-hour check sheet without finding any abnormal conditions. Mechanic B reported to Mechanic A that no abnormalities were found.

#### **2.5.4 Records of Aircraft Maintenance and Exhaust Pipe Replacement**

According to the maintenance records and flight records, the Aircraft had received a 100-hour / annual check on September 28, 2007, and a 50-hour / 6-month check on March 24, 2008, in the 12-month period prior to the accident and these records contained no entries related to problems with the exhaust system. Work sheets were not produced for either of these checks.

Earlier records indicate that the exhaust pipe was replaced on August 15, 1999, and the four exhaust manifolds and eight clamps were replaced on September 9, 2004. In the period up to March 24, 2008 after the replacement of the exhaust pipe, all manufacturer-specified checks (100-hour check, etc.) were conducted as the periods expired and three different contractors were engaged in these checks.

#### **2.5.5 Structure of the Exhaust Pipe**

The exhaust pipe collects exhaust gases through four exhaust manifolds connected to the engine cylinders, and discharges the collected gas to the outside of the Aircraft. On each side of the exhaust pipe, there are two pipes installed by welding inside the exhaust pipe to be connected to the corresponding exhaust manifolds (hereinafter each of the pipes is referred to as “Connecting Pipe”). Each Connecting Pipe was connected to the exhaust manifold by a clamp, the inner surface of which has a welded slip of sealing metal (hereinafter referred to as “the Slip”). When the clamp is tightened, the Slip located over the joint between the exhaust manifold and Connecting Pipe seals the ends of the exhaust manifold and the Connecting Pipe to prevent exhaust gas from leaking through the joint.

(See Figure 4 Exhaust System Components, Figure 5 Connecting Pipe of the Exhaust Pipe, and Photo 10 Deteriorated Weld (Inside))

#### **2.5.6 Materials of the related components**

According to the manufacturer of the Aircraft, the components of the Aircraft listed below were made of the following materials:

|                                 |                        |
|---------------------------------|------------------------|
| 1. Hose                         | Neoprene <sup>*3</sup> |
| 2. Carburetor heater hose cover | Asbestos               |
| 3. Cowlings                     | FRP <sup>*4</sup>      |
| 4. Exhaust pipe                 | Stainless steel        |
| 5. Air intake duct              | Aluminum               |

The stainless steel used is X2CrNi18-9 (classified as SUS304L by Japanese Industrial Standards). The Cowlings were lined with heat-resistant aluminum matting in areas that were in close proximity to the exhaust manifolds and exhaust pipe.

### **2.5.7 Weight and Balance**

When the accident occurred, the Aircraft's weight is estimated to have been 2,398 lbs and the position of the center of gravity is estimated to have been 41 in aft of the reference point, both of which are estimated to have been within the allowable limits (i.e., maximum takeoff weight of 2,535 lbs and allowable center-of-gravity range of 40–47 in based on the estimated Aircraft weight at the time of the accident).

### **2.5.8 Fuel and Lubricating Oil**

The Aircraft used aviation gasoline "100LL" as the fuel, and oil conforming to SAE20W-50 as the lubricating oil.

## **2.6 Meteorological Information**

Aeronautical weather observations for Nagasaki Airport around the time of the accident were as follows:

17:32 Wind direction VRB; Wind velocity 04 kt; Visibility 35 km  
 Cloud: Amount 1/8, Type Cumulus, Ceiling 3,000 ft, Amount 3/8, Type Altocumulus,  
 Cloud base 12,000 ft  
 Temperature 31°C; Dew point 23°C  
 Altimeter setting (QNH) 29.74 inHg

## **2.7 Accident Site and Wreckage Information**

### **2.7.1 Accident Site Conditions**

The accident site was located in the sea about 200 m east of Runway B of Nagasaki Airport. The Aircraft was submerged in the water after ditching except for the right wing, which had been torn off from the fuselage at the root and was floating on the water.

---

<sup>\*3</sup> Neoprene is a synthetic rubber with good resistance to oil and fire. It can be used in a wide temperature range.

<sup>\*4</sup> FRP is an acronym for Fiber-Reinforced Plastic, which is high-strength plastic made of laminated fiberglass and resin. FRP has the following general characteristics: it is highly durable, has high impact strength, is easy to form, offers radio wave penetrability, is highly resistant to heat, oil, water and fuel, and is self-extinguishing.

On the afternoon of July 27, the day after the accident, the Aircraft was found lying upside down on the seabed about 12 m below the surface of water, with the nose facing west. After being salvaged, the Aircraft was stored in a hangar at Nagasaki Airport.

## **2.7.2 Details of Damage to the Aircraft**

### **(1) Exhaust system**

The LH front manifold was found detached together with the Connecting Pipe (hereinafter referred to as “the LH Front Connecting Pipe”) from the exhaust pipe. The exhaust pipe was cut open in order to inspect the inside condition of the welded joint between the exhaust pipe and Connecting Pipe. The exhaust pipe and the Connecting Pipe had been welded together where they overlapped each other (hereinafter this area is referred to as “the Base Metal Ends”). Cracks were found in both this welded joint and the LH Front Connecting Pipe, but no abnormal conditions were found in the welded joints for the three other Connecting Pipes.

Each Connecting Pipe sustained significant damage in the area corresponding to the gap between the clamp ears. Among the Connecting pipes, the LH Front Connecting Pipe had a part with some material missing, from which a crack extended lengthwise to the welded joint, while the pipe end retained its original roundness and was free of any crushing or other deformation. Further inspection of the three other Connecting Pipes also found the following defects: the Connecting Pipe for the LH rear manifold (hereinafter referred to as “the LH Rear Connecting Pipe”) was deformed with some material missing and was angled forward including its root portion; and both the Connecting Pipe for the RH front manifold (hereinafter referred to as “the RH Front Connecting Pipe”) and the Connecting Pipe for the RH rear manifold (hereinafter referred to as “the RH Rear Connecting Pipe”) were deformed with an outward crest at the location corresponding to the gap between the clamp ears. In addition, all Slips were deformed at their ends while all Connecting Pipes and clamps were corroded.

Grayish-white deposits and soot were found on the left side surface of the exhaust pipe and the clamps there. The heat exchanger installed over the exhaust pipe had a dent in the left front area, and the exhaust pipe was found shifted rearward.

### **(2) Cowlings, carburetor and hose**

The Cowlings were found with significant burn damage, with some portions destroyed by fire, in the areas corresponding to the detached Connecting Pipe. Soot was found adhering to the left side of the airframe in the area extending from the nose towards the left wing. There was a clearance of several centimeters between the sides of the exhaust pipe and the Cowlings. While the Cowlings had been lined with aluminum matting in the areas directly opposite the right and left sides of the exhaust pipe, the left mat together with the surrounding FRP were missing.

The air intake duct and the connecting hose between the heat exchanger and air intake duct were burned.

Soot was found adhering to the carburetor. The hose for delivering outside air to the carburetor was burned out and the air filter connected to the hose was also burned.

(3) Engine, propeller and aircraft control system

The propeller blades were free of damage. The engine could be rotated without restriction by manually rotating the propeller. All control surfaces including the rudder, elevators and the ailerons could be moved without restriction.

(See Figure 4 Exhaust System Components, Figure 5 Connecting Pipe of the Exhaust Pipe, Photo 2 Lower Left Area of the Burned Engine, Photo 3 Burned Areas of the Cowlings (External Surface, Internal Surface), Photo 4 Carburetor, Photo 6 LH Side of the Exhaust Pipe, Photo 7 Fracture Surface of the Connecting Pipe, Photo 8 Connecting Pipes and Clamps (1) and (2), and Photo 10 Deteriorated Weld (Inside))

## **2.8 Medical Information**

According to the Nagasaki Prefectural Police, a judicial autopsy conducted on July 28, 2008, on the body of Pilot B found that he died from drowning. His body tested negative for both alcohol and drugs.

Pilot A was seriously injured, suffering cervical vertebrae avulsion fracture, while the Captain was slightly injured with an abrasion to the forehead.

## **2.9 Information on Search and Rescue Related to Survival, Death and Injury**

The progress of the rescue operations following the occurrence of the accident is outlined as follows, according to the Air Safety Foundation, the JMSDF Fleet Air Wing and the Omura Fire Station (statements of the station's rescue squad members).

In this accident, in which the Aircraft ditched in the sea, the Nagasaki Airport Office engaged in coordination and support in accordance with "The Agreement on Communication and Rescue Task Sharing in Civil Aircraft Accident, Related Search and Other Emergencies at Nagasaki Airport and the Vicinities" (hereinafter referred to as "the Agreement") signed by the Nagasaki Airport Office, the JMSDF Fleet Air Wing, the Japan Coast Guard, the Omura Fire Station and other relevant organizations and in accordance with the "The Nagasaki Airport Firefighting and Rescue Operations Manual," while the JMSDF Fleet Air Wing and the Omura Fire Station engaged in rescue operations for the injured in accordance with the Agreement.

### **2.9.1 Air Safety Foundation**

At 17:23, the Air Safety Foundation received an emergency call informing them of a small aircraft having caught fire and ditching in the sea. Three staff members were immediately sent out in vehicles to the peripheral road near the accident site. At 17:24, the Air Safety Foundation placed a call over the direct line to the Nagasaki Prefectural Fire Department Command Center (hereinafter referred to as "the Command Center") and reported the accident. However, the quality of the line made it difficult for the Command Center to listen to the call, they understood only that an accident had occurred but could not identify the location of the accident site. The Air Safety Foundation therefore hung up the direct line and

called back on a subscriber line by dialing 119 to convey the location of the accident site.

At 17:26, the dispatched staff members arrived at the seawall near the accident site and saw two pilots swimming to shore. They cheered the swimming pilots and, when an Omura Fire Station rescue squad arrived, helped them with the rescue operation.

After the accident-related operations were over, the Air Safety Foundation checked the direct line to the Command Center but did not find any abnormalities.

### **2.9.2 JMSDF Fleet Air Wing**

The JMSDF Fleet Air Wing deploys non-resident rescue staff members to deal with accidents involving their operations but does not have dedicated vessels for rescue operations. They do, however, have support vessels for maritime operations and they use these for emergency rescue operations.

Since the JMSDF Fleet Air Wing did not have any planned flights on the day of the accident, they had not deployed any rescue staff and the support vessels were docked for maintenance. The Fleet Air Wing immediately made an emergency call up of rescue members and dispatched them on another vessel at 17:55. The rescue squad pulled the Captain onboard from the sea at 18:07.

### **2.9.3 Omura Fire Station Rescue Squad**

(1) Statement of the Chief of the Omura Fire Station Rescue Squad

At 17:29, the Rescue Squad received a mobilization order from the Command Center. At 17:30, ambulances, rescue vehicles and water trucks were dispatched from the Omura Fire Station and arrived at the airport gate at 17:36. When the vehicles entered the airport and arrived at the gate near the accident site, I went to the seawall and saw two men (Pilot A and Pilot B) swimming toward the seawall and I also saw a third person (the Captain), only vaguely however, near a floating broken wing in the sea about 200 m away. At 17:39, I immediately ordered two rescuers (hereinafter referred to as “Rescuer A” and “Rescuer B”) for rescue operation of the pilots. At 17:45, Rescuer A rescued one of the pilots (Pilot B) who was nearest to the shore and at 17:52, Rescuer B rescued another pilot (Pilot A). The pilot rescued by Rescuer A was suffering cardiopulmonary arrest and was given resuscitation by the ambulance crew and a doctor who happened to be at the airport at that time. Subsequently, following the doctor’s instructions, Pilot A and Pilot B were loaded onto ambulances and taken to hospitals at 18:03 and 18:07, respectively. The pilot (Captain) who was farthest away from the shore was rescued by a vessel of the JMSDF Fleet Air Wing at 18:07 and taken to hospital by ambulance at 18:36.

(2) Statement of Rescuer A

As soon as Rescuer B and I arrived at the site on a rescue vehicle, we wore life jackets and, carrying a set of life buoys, tethers and other items, went to the seawall. I set out to rescue the pilot (Pilot B) who was nearest to the shore and was swimming toward us. When I entered the sea, he was lying face down in the water. I reached out and touched him to check if he was conscious and breathing but he showed no reaction. I turned him over onto his back to secure a respiratory passage and immediately instructed those on shore to pull

him ashore. After pulling him up on the seawall, I handed him over to the ambulance crew.

(3) Statement of Rescuer B

When Rescuer A and I reached the seawall together, Rescuer A dived first into the sea and then, after confirming that Rescuer A had come in contact with the first pilot, I set out to rescue the second pilot (Pilot A). He was treading water and was able to respond to my words when I spoke to him, so I put a life buoy on him and instructed those on shore to pull him ashore. After pulling him up onto the seawall, I handed him over to the ambulance crew.

(See Figure 2 Rescue Site)

## 2.10 Emergency Equipment on the Aircraft

While the Aircraft was equipped with the required number of life jackets for the capacity number of persons for the Aircraft, these jackets were not used.

## 2.11 Additional Information

### 2.11.1 Pre-Flight Inspection

The flight manual contains the following pre-flight inspection procedure. (Excerpts)

*Nose Section*

|                             |              |
|-----------------------------|--------------|
| <i>Cowling installation</i> | <i>Check</i> |
|-----------------------------|--------------|

(The rest is omitted)

### 2.11.2 Regular Maintenance

The maintenance manual issued by the manufacturer of the Aircraft contains the following scheduled maintenance procedures for inspection of the exhaust pipe and removal, installation and inspection of the exhaust system. There had been no service bulletins or other technical instructions from the manufacturer concerning the area of the exhaust pipe that became detached in the accident. (Excerpts)

(1) 2A INSPECTION – 50 HOURS

① 71-10 Remove upper engine cowling 121 and lower engine cowlings 131 and 132. Visually inspect for cracks, wear, evidence of leaks (oil, fuel, air, exhaust gas) and security.

②-⑤ (Skipped)

⑥ 78-00 Visually inspect the exhaust pipe, the exchanger (and the muffler if installed), and thoroughly inspect the attach fitting, the casings and welds for cracks.

(The rest omitted)

(2) 4A INSPECTION – 100 HOURS

① 71-10 Remove upper engine cowling 121 and lower engine cowlings 131 and 132. Visually inspect for cracks, wear, evidence of leaks (oil, fuel, air, exhaust gas) and security.

②-⑦ (Skipped)

⑧ 78-00 Remove the heat exchanger and the exhaust pipe (and the muffler, if installed)



– refer to 78-00-00 401.

- ⑨ 78-00 *Thoroughly inspect the attach fittings, the tubes, the exhaust pipe, the exchanger (and the muffler, if installed). Look for welding defects and cracks on the inner and outer casings – refer to 78-00-00 401.*

(The rest omitted)

(3) *ANNUAL INSPECTION (AI)*

The ANNUAL INSPECTION consists of the same inspection items as in the 4A INSPECTION – 100 HOURS 78-00.

(4) *Exhaust Removal/Installation (Figure 401)*

1. *Removal of the exhaust (Figure 401)*

A (Skipped)

B *Procedure*

1) – 4) (Skipped)

All

5) (Skipped)

6) *Remove nuts, spacers, bolts, and clamps, on LH front pipe, LH rear pipe, RH front pipe, and RH rear pipe while holding the exhaust assembly. Discard nuts.*

7) *Remove the exhaust assembly.*

8) – 9) (Omitted)

2. *Installation of the exhaust*

A (Skipped)

B *Procedure*

1) *Check the condition of the exhaust assembly – refer to Page 601*

2) – 3) (Skipped)

4) *Position clamps, make flanges of mounting flanges and of pipes properly coincide with clamp grooves.*

*Pay particular attention to the metallic strip position inside clamp.*

*This strip is spot welded inside the clamp and is used as a tightness strip for this clamp.*

5) – 11) (Skipped)

*Caution: Ensure a correct tightening in order to hinder the element relative rotation.*

*An excessive tightening will cause the clamp ears distortion.*

*This is unacceptable when the ear ends are in contact.*

(The rest omitted)

(5) *Exhaust Inspection/Check 78-00-00 Page 601*

1. *Check of the exhaust*

A (Skipped)

B *Procedure*

- 1) *Check for leak*
- 2) *(Skipped)*
- 3) *Check welded flanges of pipes, mounting flanges and exhaust pipe. Straighten (if necessary) the ends.*

*Note: Straighten the exhaust pipe and pipe cylindrical parts, then do a dimension check.*

*If an aspect of dimension defect is detected on the pipes, mounting flange and exhaust pipe after rectifications, the concerned part must be discarded and replaced.*

- 4) – 5) *(Skipped)*
- 6) *Check clamps to check for cracks and distortions. Check condition and attachment of metallic seal band inside the clamp. For any defect, discard and replace the clamp.*

(The rest omitted)

### **2.11.3 50-Hour Check**

The Company had been carrying out inspection and maintenance operations on the Aircraft's exhaust system as per the 50-hour check sheet that it had established in accordance with Aircraft Inspection Operation Circular No. 3-013 issued by the Civil Aviation Bureau of the Ministry of Land, Infrastructure, Transport and Tourism as shown below. (Excerpts)

*Thoroughly inspect the entire exhaust system for exhaust gas leakage.*

*Clean the entire surface of the exhaust system.*

*Thoroughly inspect the following areas.*

*Disassemble the shrouds for the heat exchanger. Use a light and a magnifying glass as needed.*

- A. *Check the muffler and the heat exchanger for normal conditions and absence of leakage.*
- B. *Check for gas leakage through the exhaust stack gaskets (blow-by passing through the gaskets).*
- C. *Check the clamp joints, fittings and stacks for looseness and damage.*
- D. *Check the exhaust stacks and piping for cracks and other damage.*
- E. *Check the exhaust stacks for dents.*
- F. *Check the welds and stack bends for cracks.*
- G. *Check the joints for reduced stock thickness due to wear resulting from vibration.*
- H. *Check for pitting in metal parts resulting from internal erosion caused by corrosive products of combustion.*

### **2.11.4 Welds**

The weld at the Base Metal Ends of the Aircraft had been made by means of fusion welding in which the base metal is melted to produce a metal-to-metal joint. The welding method employed was gas-shielded arc welding whereby argon gas is used as the shielding gas to protect the weld area from the

atmosphere.

The stainless steel used on the Aircraft was X2CrNi18-9 (SUS304L as classified by Japanese Industrial Standards), which is ultra-low carbon steel highly resistant to intergranular corrosion <sup>\*5</sup>.

With the cooperation of the Japan Aerospace Exploration Agency (JAXA), an independent administrative institution, the weld of the LH Front Connecting Pipe was analyzed. The results showed adequate penetration and no abnormalities in the weld.

### 2.11.5 Stainless Steel

Stainless steel is an alloy containing steel as the main component and chromium and nickel as other component. About 12% or higher chromium content provides the alloy with increased resistance to corrosion, and the formation of an ultra-thin oxide layer called passive film on the surface of the stainless steel protects it from corrosion. One of the characteristics of passive film is its ability to quickly restore itself even if it is destroyed.

Corrosion of stainless steel can start when the passive film loses its self-restorability. Typical examples of such corrosion include intergranular corrosion and stress-corrosion cracking <sup>\*6</sup> whereby the passive film is destroyed locally by external stress, etc., resulting in localized corrosion on the surface of the stainless steel. Major environmental factors that contribute to such corrosion include temperature, humidity, and especially salinity that causes chloride ions to work as a detrimental factor.

### 2.11.6 Examination of the Exhaust Manifolds and Connecting Pipes

- (1) The actual measurements of the diameter of the exhaust manifolds, Connecting Pipes and flanges used in the Aircraft are as follows:

|                                      |                 |
|--------------------------------------|-----------------|
| ① Diameter of exhaust manifolds      | Approx. 45 mm   |
| ② Diameter of Connecting Pipes       | Approx. 45 mm   |
| ③ Diameter of flanges                | Approx. 48.6 mm |
| ④ Wall thickness of exhaust manifold | Approx. 1.0 mm  |
| ⑤ Wall thickness of Connecting Pipe  | Approx. 0.6 mm  |

- (2) The Connecting Pipes and clamps installed on the Aircraft were in the following condition:

- ① All the clamps on the exhaust pipe side were found installed with both ears touching each other.
- When the clamps were removed, the clearance between the ears of each clamp measured approximately 3 mm. When each clamp was tightened until its ears touched each other without placing the Connecting Pipe inside, the diameter of the Slip portion measured approximately 44.0 mm.
- Each of the Connecting Pipes had missing material and a crest-shaped deformation.

---

<sup>\*5</sup> Intergranular corrosion occurs as a result of chromium carbide precipitation, which is generated by the heat from welding together pieces of stainless steel. The heat causes the chromium and carbon in the stainless steel to combine, which results in the chromium carbide precipitation.

<sup>\*6</sup> Stress-corrosion cracking occurs in equipment material due to residual stress caused by welding, press forming, bending, etc. during its assembly and also due to external stress and corrosive action working on the equipment during its use.

Only one portion with missing material and a crest-shaped deformation was found on each Connecting Pipe; no such portions were found on any other peripheral areas of the Connecting Pipes. The clamp can be installed on the periphery of each Connecting Pipe at any angle as long as its ears do not touch the flange of the exhaust pipe or the ears of another clamp either at the front or the rear.

- ④ Both the RH Front Connecting Pipe and RH Rear Connecting Pipe showed no signs of repair for their crest-shaped deformation areas.

### **2.11.7 Examination Using a New Clamp**

The following measurements were taken using a new clamp:

- (1) Diameter of the Slip portion when the clamp was tightened until its ears touched each other with no Connecting Pipe placed inside ... approx. 43 mm
- (2) Clearance between the ears when the clamp was installed on a Connecting Pipe and tightened until the ends of the Slip overlapped by 2 mm ... approx. 4.9 mm.
- (3) Beginning with the state of (2) above, the clamp was further tightened. The end of the Connecting Pipe then started to deform at the portion corresponding to the gap between the clamp's ears. At that time, the clearance between the ears measured approx. 2.7 mm. As the clamp was further tightened, the deformation increased, turning into a crest shape.
- (4) The tightening torque applied in (2) and (3) above was between 15 and 17 in-lb.

(See Figure 6 Deformation of Connecting Pipe by Tightening of Clamp, Photo 8 Connecting Pipes and Clamps (1) and (2), and Photo 9 Examination Using a New Clamp (1) and (2))

### **2.11.8 Logbook Entries**

According to the entries in the logbook, both Pilot A and Pilot B continued to fly with their flying club even after the expiration of their aviation medical certificates. Including the outward journey flight on the day of the accident, Pilot A flew 3 times and Pilot B flew 75 times during a period of about 12 months.

### **3. ANALYSIS**

#### **3.1 Flight Crew Qualifications**

The Captain held a valid airman competence certificate and a valid aviation medical certificate.

Pilot A and Pilot B both held a valid airman competence certificate but did not held a valid aviation medical certificate.

#### **3.2 Aircraft Airworthiness Certificate**

The Aircraft had a valid airworthiness certificate.

#### **3.3 Meteorological Conditions**

It is considered highly probable that the meteorological conditions prevailing at the time had no relevance to the occurrence of the accident.

#### **3.4 Progress of Events Leading to the Fire and Ditching**

It is considered highly probable that, the fire on the Aircraft was caused by hot exhaust gases blasted into the engine compartment due to the detachment of the LH front manifold together with the LH Front Connecting Pipe as described in 2.7.2 (1), burning the Cowlings near the left side of the exhaust pipe and the hose leading to the carburetor that was located at the rear of the exhaust pipe. It is also considered highly probable that the Cowlings, lined with heat-resistant aluminum matting in the inside areas near the exhaust manifolds and the exhaust pipe, were burned as blasts of hot exhaust gases extended even to the areas not protected by the heat-resistant aluminum matting.

With regard to the rearward dislocation of the exhaust pipe, it is considered highly probable that, judging from the fact that the heat exchanger had a dent on the left front area and that the LH Rear Connecting Pipe including its root was tilted forward, the burned Cowlings pushed the left front area of the heat exchanger after being subjected to pushing force from the front during the ditching. Nevertheless, the end opening of the LH Front Connecting Pipe retained its original roundness and was free of any crushing or other deformation. Therefore, it is considered highly probable that the time when the Connecting Pipe become detached was not at the time of pressure application from the front during the ditching but was just after takeoff since smoke and odors entered the cockpit soon after takeoff, as described in 2.1 (1) and (2).

According to the statement in 2.1 (1), the Aircraft was unable to maintain altitude while flying on the right downwind leg. Therefore, it is considered highly probable that the Aircraft started losing altitude because it fell into a condition in which the engine thrust necessary to continue flying was no longer available as a consequence of the engine's inability to continue normal combustion due to the damaged air intake duct and air filter by fire and also due to the inflow of smoke (air containing soot and other impurities) resulting from the fire as well as hot exhaust gases (as the gases were hot, the air density was low and the gases contained carbon monoxide and carbon dioxide) into the engine via the carburetor. It is considered highly probable that this situation prompted Pilot B to give up flying and make a right turn for

ditching.

As the statements described in 2.1 (1) and (2) indicate, the propeller blades continued to rotate until ditching, but despite the throttle lever and other controls found in the maximum-power position as described in 2.3.3, the propeller blades were found to be free of damage, as described in 2.7.2 (3). Therefore, it is considered possible that the engine had stopped before ditching.

### **3.5 Cause of the Damage to the Connecting Pipes**

As described in 2.7.2 (1), each Connecting Pipe sustained significant damage in the area corresponding to the gap between the ears of the clamp. The damage was a crest-shaped deformation on the right-hand Connecting Pipes and missing material and cracks on the left-hand Connecting Pipes. As described in 2.11.6 (2), the ears of every clamp were found touching each other.

As described in 2.5.5, the clamp is designed to join the end of an exhaust manifold with the end of the corresponding Connecting Pipe by sealing them with a Slip. As described in 2.11.2 (4), the maintenance manual states that the clamp ears should not be touching each other.

In the examination conducted using a new clamp, as described in 2.11.7, the Connecting Pipe was deformed when the clamp was tightened excessively. Given that the diameter of both the exhaust manifold and the Connecting Pipe is approximately 45 mm, the wall thickness of the exhaust manifold is approximately 1 mm while that of the Connecting Pipe is approximately 0.6 mm, as described in 2.11.6 (1), and the Connecting Pipe is fixed by welding on one end, it is considered probable that the Connecting Pipe with smaller wall thickness was the first to be affected in the area corresponding to the gap between the clamp ears by excessive tightening. In other words, it is considered highly probable that, as the clamp was tightened excessively, the Connecting Pipe buckled and deformed into a crest shape in the area corresponding to the gap between the clamp ears until its diameter conformed to the diameter of the Slip. Therefore, judging from the fact that the ears of each clamp were found in contact with each other, it is considered highly probable that the Connecting Pipes of the Aircraft would have also been subjected to plastic deformation as a result of excessive tightening of the clamps.

With regard to the missing material on the ends of the LH Front and LH Rear Connecting Pipes attached to the exhaust pipe, it is considered probable that the missing material on each pipe was the result of the following process: The area that became structurally weak due to fine cracks and other defects caused by the plastic deformation was then subjected to expansion by the heat of the running engine as well as by contraction and vibration, which gradually made the cracks larger and these cracks further progressed under the influence of oxides contained in the exhaust gases resulting from the combustion of sulfur and other substances in the fuel and also of the corrosive action of the humidity and salt contained in atmospheric air, as described in 2.11.5, resulting in the missing material. It is considered highly probable that the missing material area of the LH Front Connecting Pipe was continuously subjected to the forces mentioned above, which caused the cracks to grow further and when the cracks reached the weld surface, cracks ran in the weld surface also; these cracks in the weld surface grew with the clamp tightening forces and under the influence of heat and vibration and gradually covered the entire weld; eventually the LH Front Connecting Pipe became detached from the exhaust pipe.

While the above description explains the step-by-step process ending in cracking of the

Connecting Pipe beginning with the occurrence of plastic deformation to the missing material and cracks, it could not be revealed the specific process in a time series. However, judging from the sufficient weld penetration as described in 2.11.4, it is considered probable that there were no abnormalities on the weld surfaces.

### **3.6 Maintenance of the Exhaust System**

As described in 2.5.3, the mechanics state that they conducted 100-hour and 50-hour checks on the exhaust system according to the relevant instructions in the maintenance manual and the 50-hour check sheet, and found no abnormalities as a result. As described in 2.5.4, the Aircraft's maintenance records included no entries of any problems in the exhaust system. Nevertheless, as work sheets were not produced, records of specific operations conducted and measurements taken were not available.

As described in 2.11.2 (4) 2, the maintenance manual states in the instructions under the Caution heading that the clamp ears should not be in contact with each other. However, as described in 2.11.6 (2) ①, the ears were found in contact with each other for all the exhaust pipe side clamps. Therefore, it is considered highly probable that the clamps were not tightened respecting this instruction in the maintenance manual. In addition, as described in 2.11.6 (2) ③, despite the fact that a clamp can be installed on the periphery of a Connecting Pipe at any angle as long as the ears do not interfere with other component parts, missing material and deformation were found at only one location on every Connecting Pipe and any damage that would have been caused by excessive clamp tightening was not found in any other areas on the pipe. As described in 2.5.4, the exhaust pipe had been used on the Aircraft for about nine years. Considering that every Connecting Pipe had missing material or deformation in just one location even though three different contractors had worked on the Aircraft for the annual 100-hour and 50-hour checks during that period and the areas in question were inspected a total of 18 times including the parts replacement operation conducted on September 9, 2004, it is considered possible that the procedure in the maintenance manual described in 2.11.2 was not respected.

As described in 3.5, deterioration of the Connecting Pipe generally progresses gradually and it takes a certain period of time for cracks to emerge and lead to fracture. Therefore, it is considered possible that signs of failure could have been noticed during the regular checks.

### **3.7 Possibility of the Captain and the Other Pilots Noticing the Deterioration of the Connecting Pipe before the Accident**

As indicated by the statements described in 2.1 (1) and (2), the Captain, Pilot A and Pilot B conducted pre-flight inspections as per the flight manual. Considering that the Captain, Pilot A and Pilot B had never opened the Cowlings during pre-flight inspections and that they had not experienced any abnormalities during pre-flight test runs of the engine and flights, it is considered highly probable that they could not know about the deterioration in the exhaust pipe prior to the accident.

### **3.8 Rescue Operations**

As described in 2.9, following a call by the Air Safety Foundation about the accident soon after its occurrence, the Omura Fire Station dispatched a rescue squad upon reception of the order from the

Command Center. The Air Safety Foundation's first call to the Command Center was indistinct, so the Air Safety Foundation called back on a subscriber line by dialing 119 to convey the message.

As the accident occurred in the sea, the rescue squad prepared life buoys, tethers and other necessary items on arrival at the site, then, observing the persons needing rescue in addition to other conditions, and promptly set out to rescue them. On the other hand, the JMSDF Fleet Air Wing, which had no rescue staff deployed and its support vessel was docked for maintenance the day of the accident, called out the rescue members and sent them out on another vessel soon after the occurrence of the accident.

In the above circumstances, the following time was spent since the time the accident occurred: 16 minutes for the Omura Fire Station rescue squad to start rescue operations, 22 minutes for Pilot B to be rescued, 29 minutes for Pilot A to be rescued, and 44 minutes for the Captain to be rescued.

### **3.9 Responses of the Pilots to the Ditching**

As described in 2.1 (1) and 2.8, it is considered probable that Pilot B escaped from the sinking Aircraft and then drowned while swimming in an attempt to reach the seawall. With regard to the fact that the Captain and pilots did not wear life jackets when they were rescued although the Aircraft was equipped with the required number of life jackets, as described in 2.10, and these were stowed in a readily accessible place in the cockpit, it is considered highly probable that the contributing factor was as follows: they did not have enough time to put on the life jackets because the Aircraft made a right turn and ditched immediately after the decision to ditch, and water poured into the Aircraft instantly, which did not allow them to do anything other than escape.



#### **4. PROBABLE CAUSE**

It is considered highly probable that the Aircraft was involved in this accident through the following series of events: the detachment of the LH front manifold together with the LH Front Connecting Pipe causing hot exhaust gases to blast into the engine compartment, which burned the Cowlings and the hose near the left side of the exhaust pipe and a fire broke out, and then hot exhaust gases together with the smoke from the fire entered the engine through the carburetor, which prevented the engine from generating enough thrust for flying, and this forced the Aircraft to ditch and eventually to be destroyed.

With regard to the detachment of the LH Front Connecting Pipe, it is considered highly probable that the contributing factors were that the clamp was tightened excessively, causing cracks in the pipe, and the cracks then grew under the influence of corrosive action working on the cracks.

## **5. SAFETY OPINIONS**

**5.1** In this accident, it is considered highly probable that the instructions written in English in the maintenance manual issued by the manufacturer of the Aircraft were not respected, which resulted in excessive tightening of the clamp, causing cracks in the Connecting Pipe. It is also considered possible that the cracks could have been detected during the regular checks.

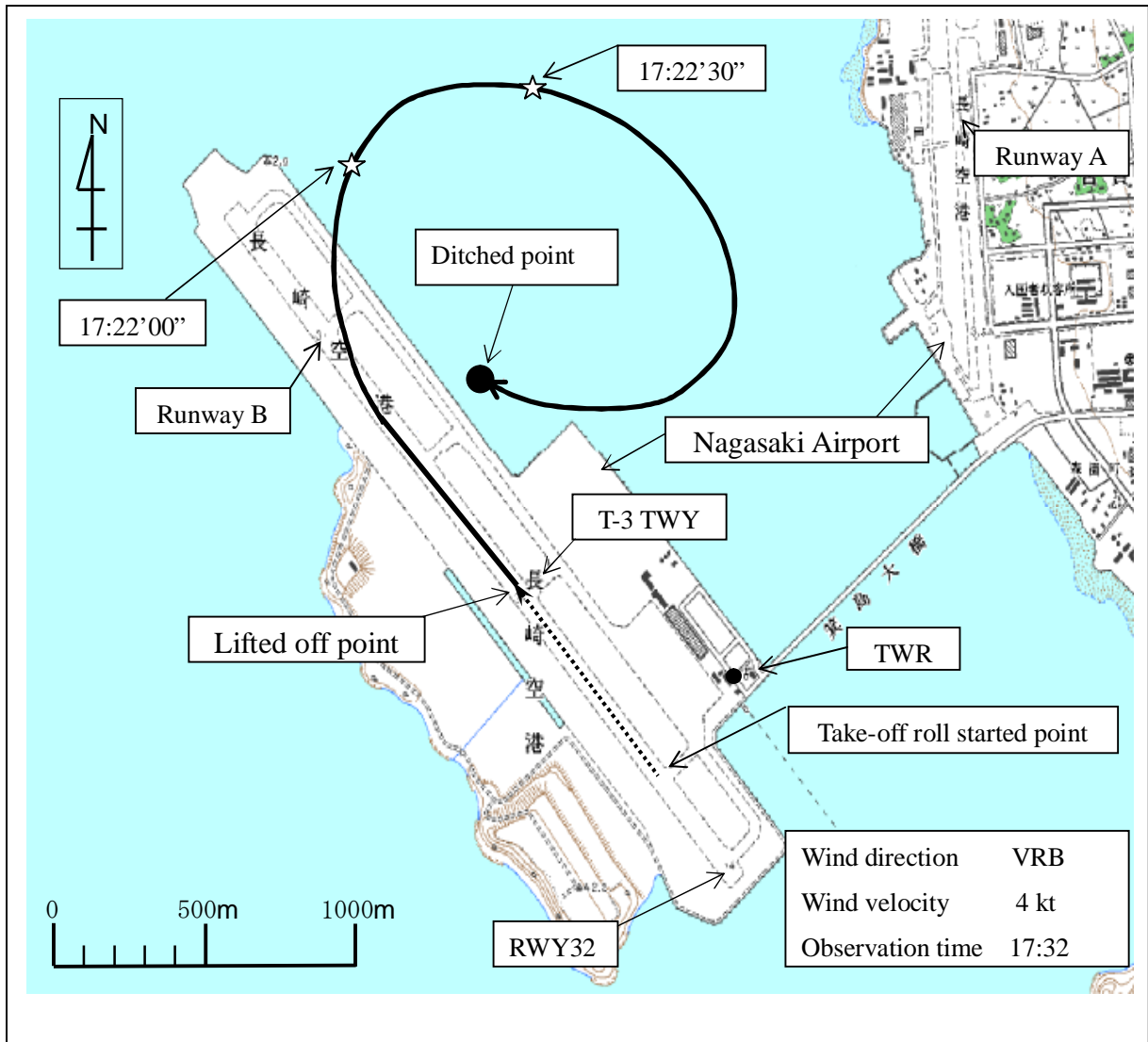
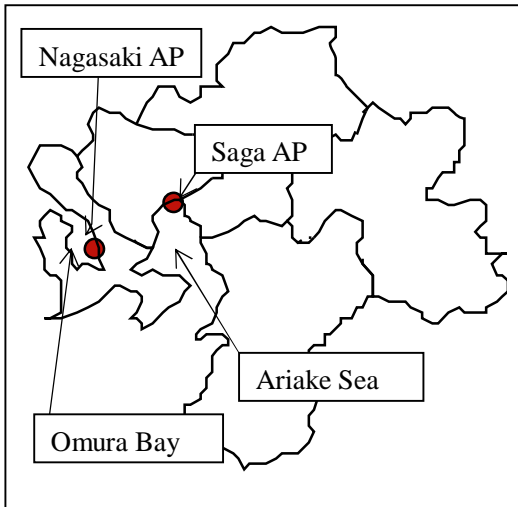
It is desirable that the Civil Aviation Bureau of the Ministry of Land, Infrastructure, Transport and Tourism instruct the operators of aircraft of the same type as the Aircraft to check the exhaust pipe connections for any faults and also ensure that all small plane operators conduct maintenance operations including necessary tightening of parts and inspections to find problems without fail by following the manuals issued by the aircraft manufacturers and complying with relevant regulatory requirements.

**5.2** It is desirable that the Civil Aviation Bureau of the Ministry of Land, Infrastructure, Transport and Tourism review and verify the current rescue system for ditching and other similar cases in the sea near airports.

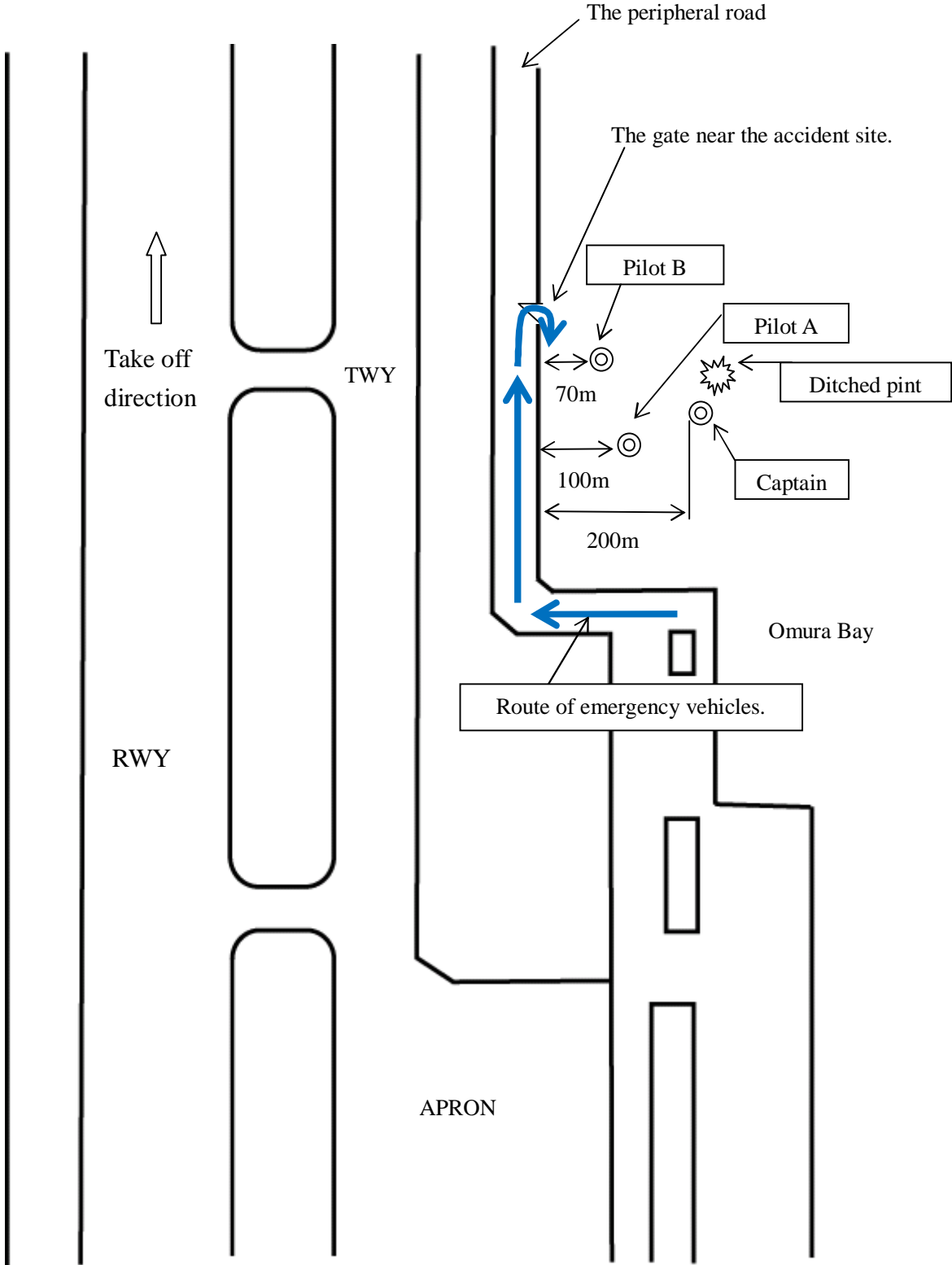
## **6. REFERENTIAL MATTERS**

After this accident, the Nagasaki Airport Office of the Osaka Regional Civil Aviation Bureau of the Ministry of Land, Infrastructure, Transport and Tourism was equipped with life jackets and buoys. The Nagasaki Airport Office also signed “The Agreement on Maritime Rescue Operations around Nagasaki Airport” with shipping companies serving the Nagasaki Airport in addition to the Omura fishermen’s cooperatives with which it had already concluded the same agreement.

**Figure 1 Estimated Flight Route**

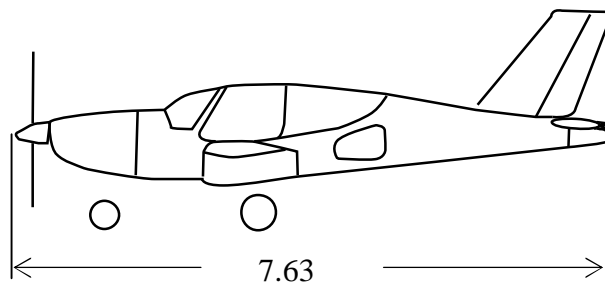
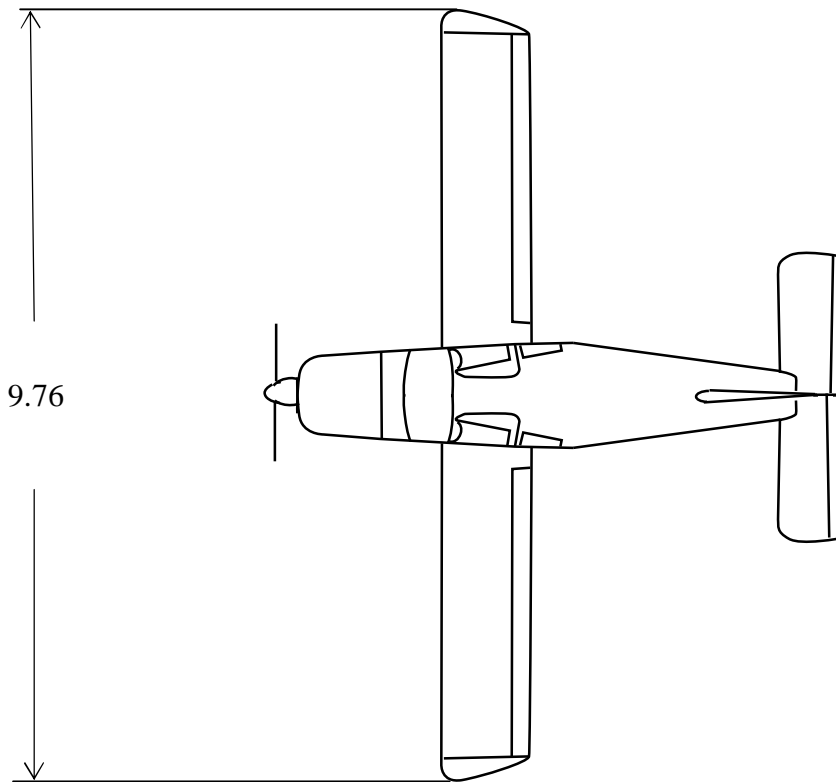
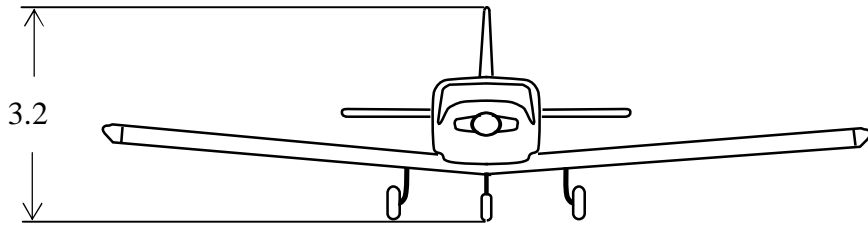


**Figure 2 Rescue site**

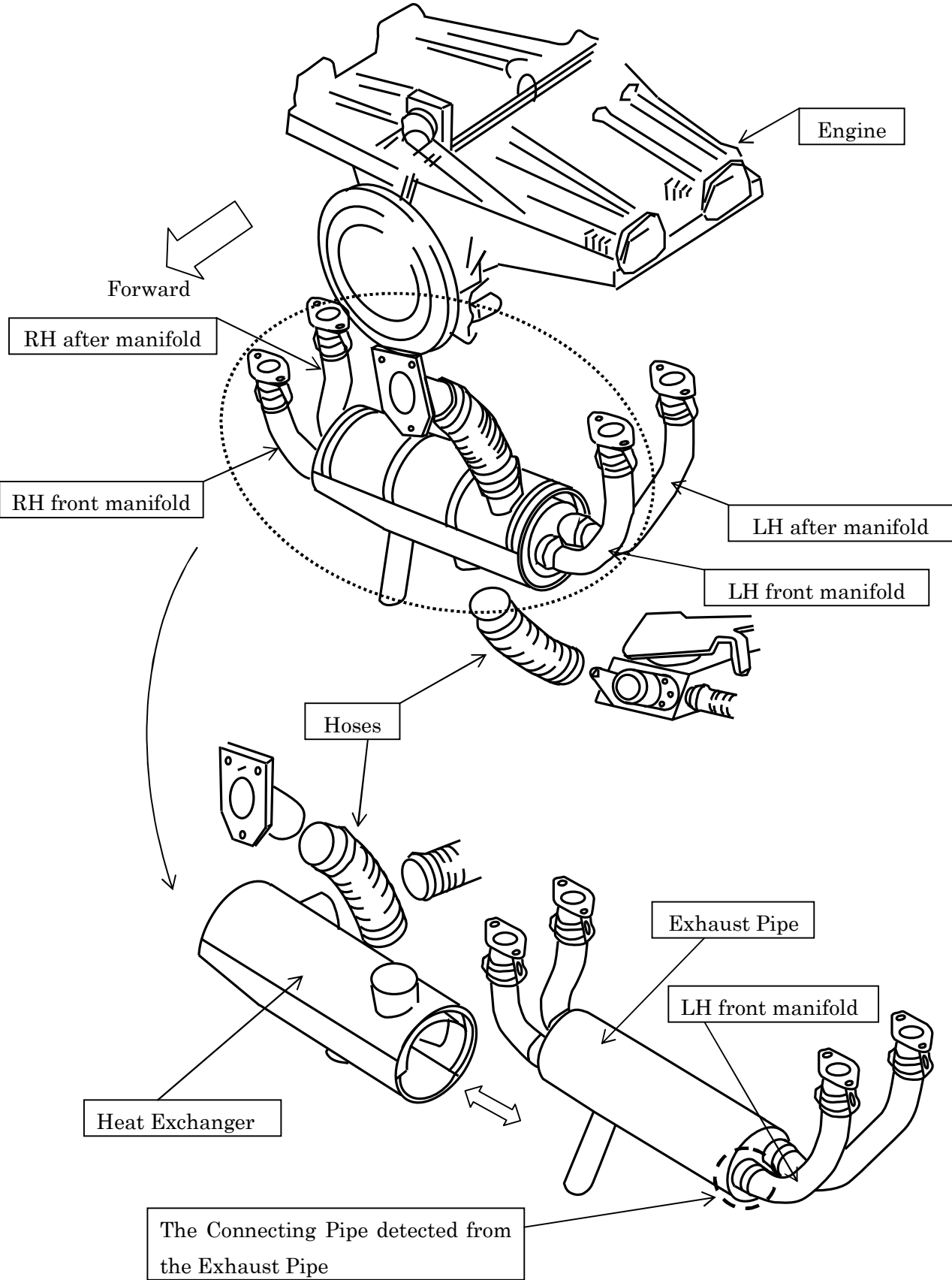


**Figure 3 Three Angle Views of SOCATA TB10**

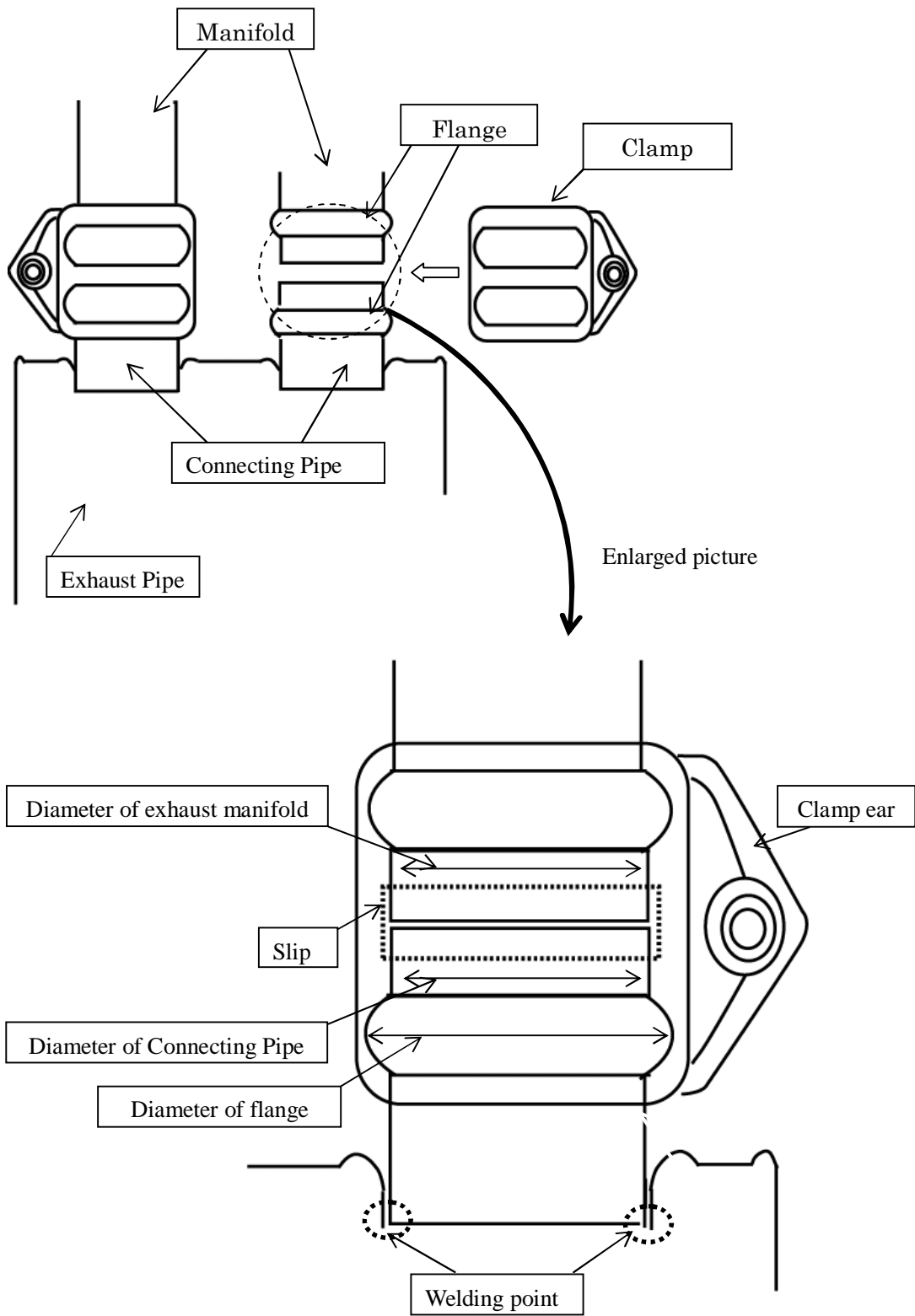
unit : m



**Figure4 Exhaust System Components**

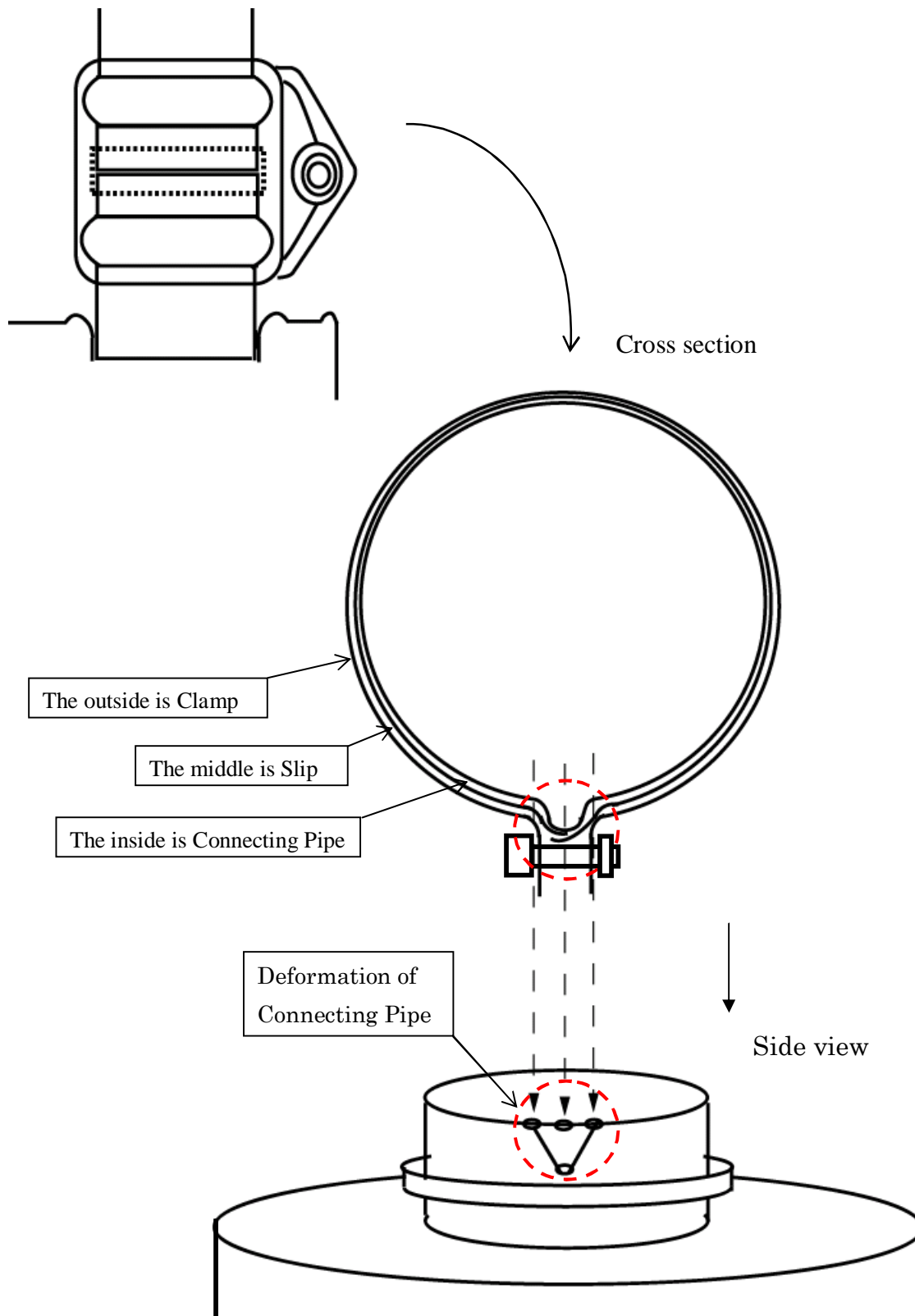


**Figure5 Connecting Pipe of the Exhaust Pipe**





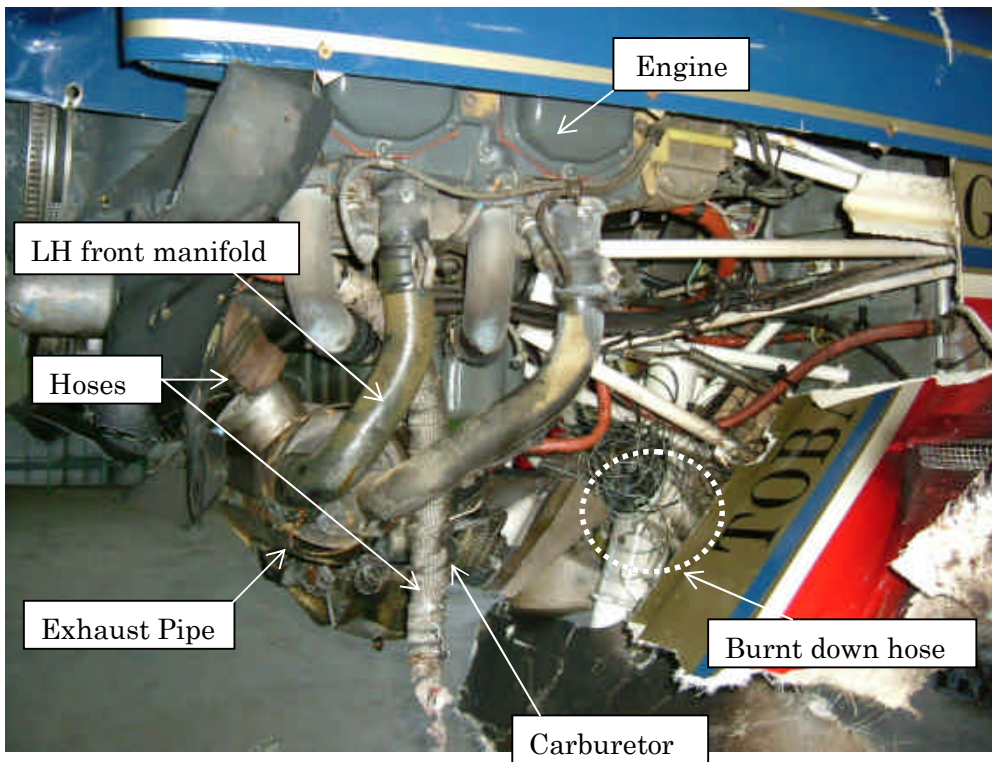
**Figure 6 Deformation of Connecting Pipe by Tightening of Clamp**



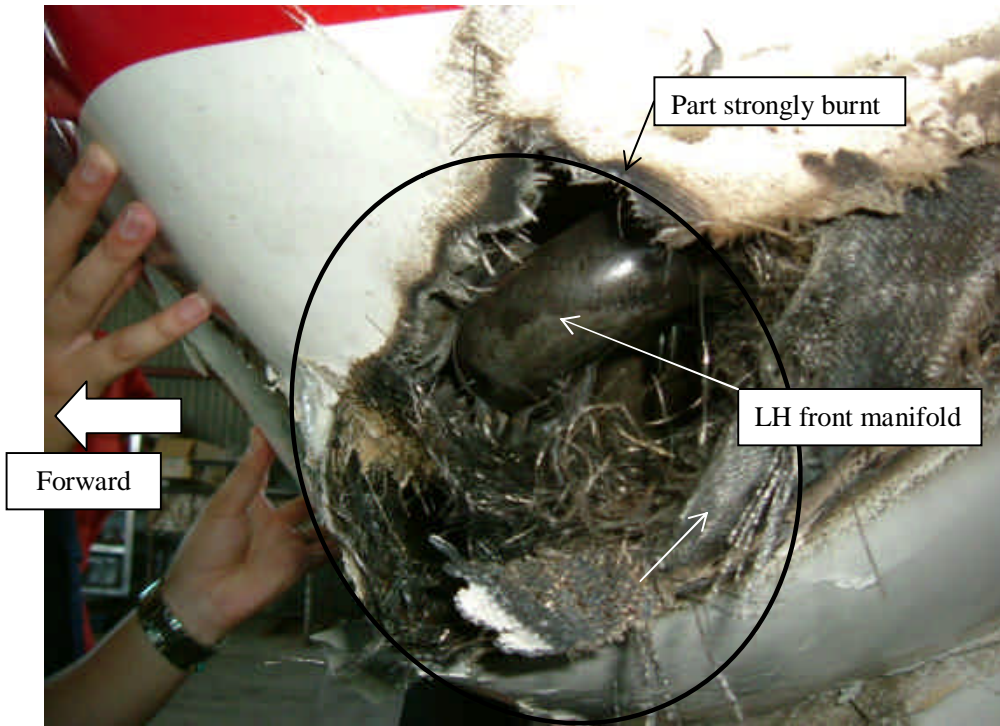
**Photo 1 Accident Aircraft**



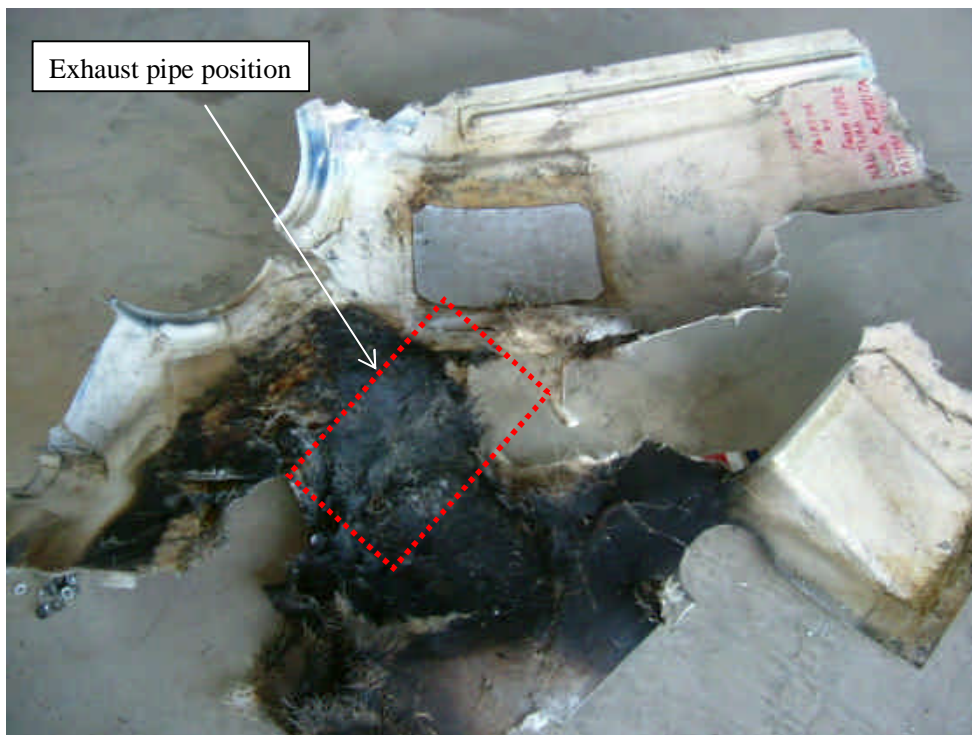
**Photo 2 Lower Left Area of the Burned Engine**



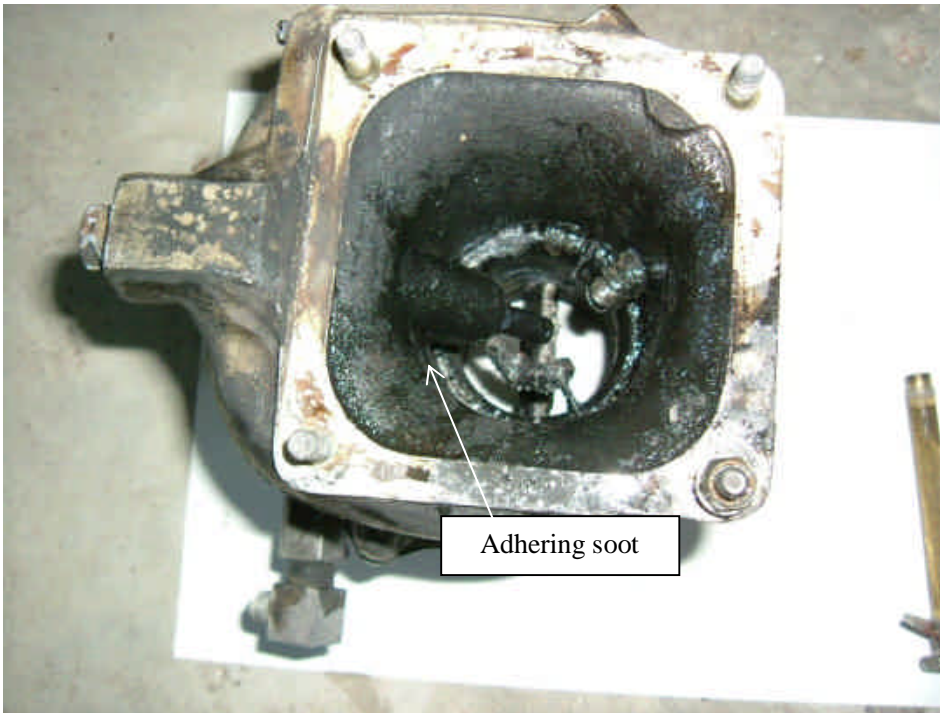
**Photo 3 Burned Areas of the Cowlings (External Surface)**



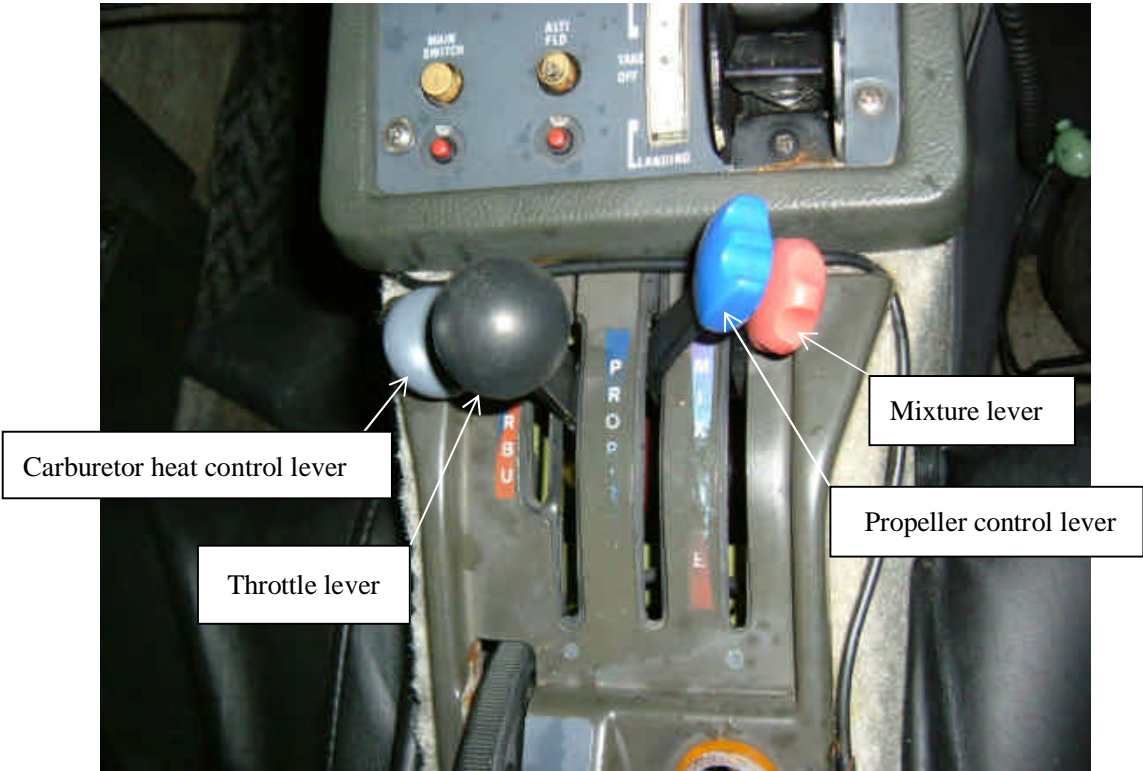
**Photo 3 Burned Areas of the Cowlings (Internal Surface)**



**Photo 4 Carburetor**

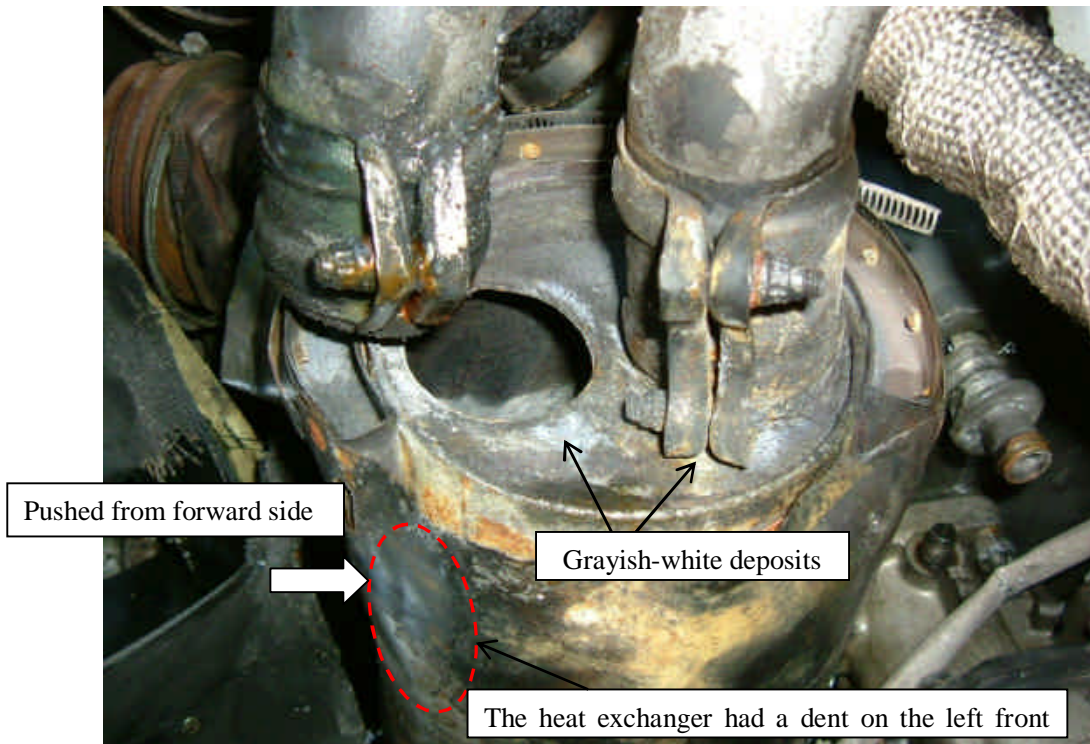


**Photo 5 Positions of the Control Levers**

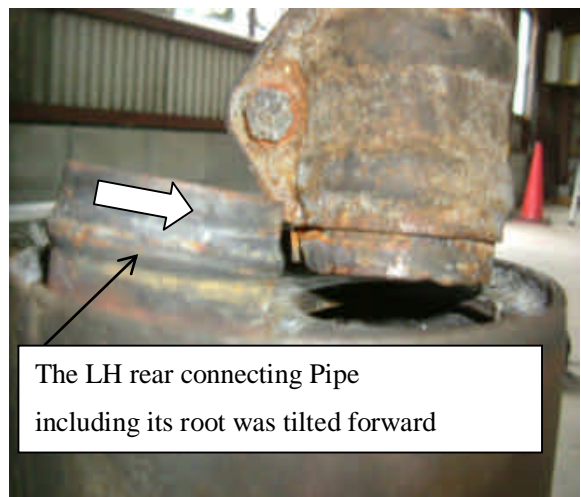
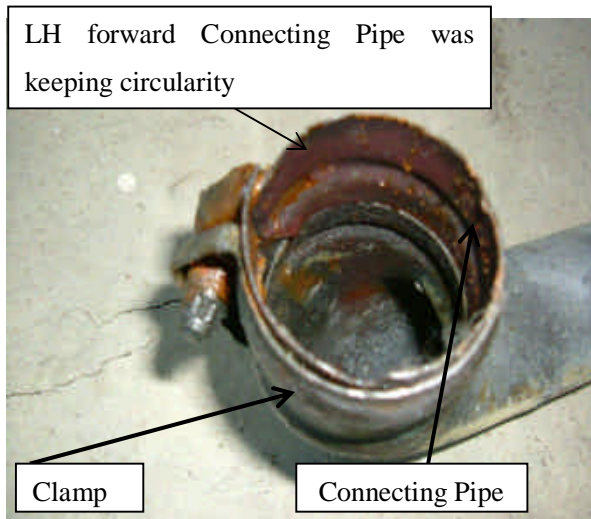


### Photo 6 LH Side of the Exhaust Pipe

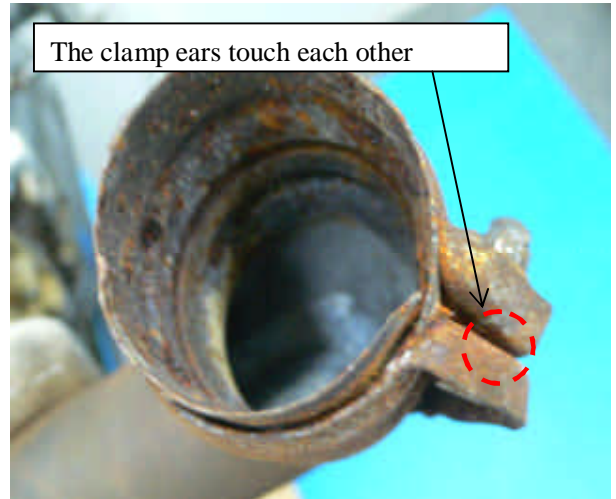
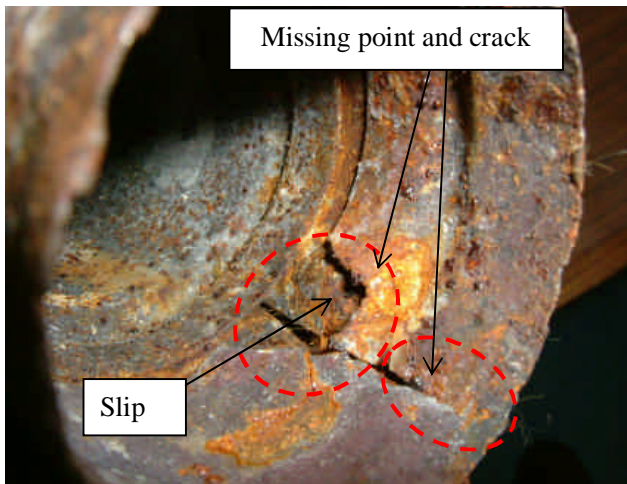
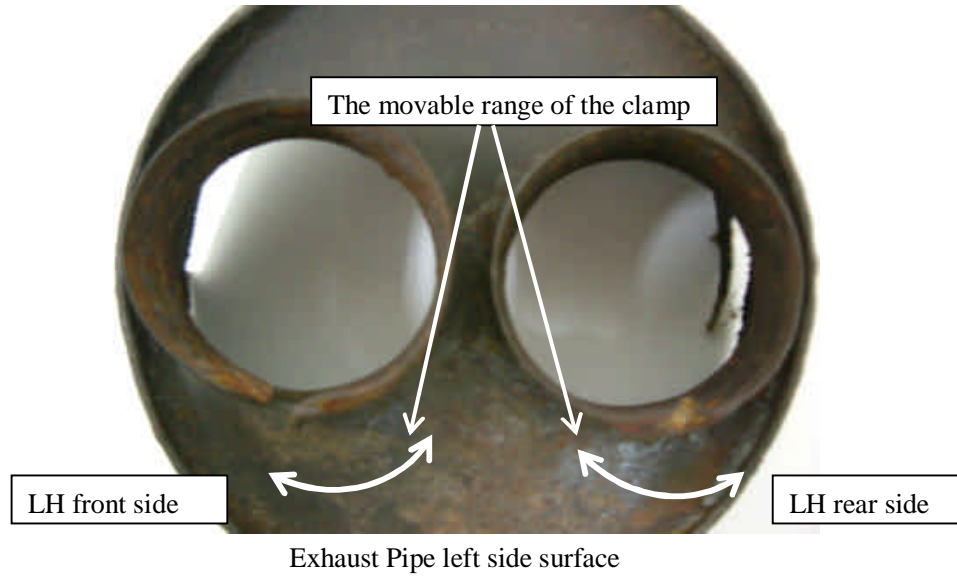
The LH front manifold was found detached together with Connecting Pipe and Grayish-white deposits.



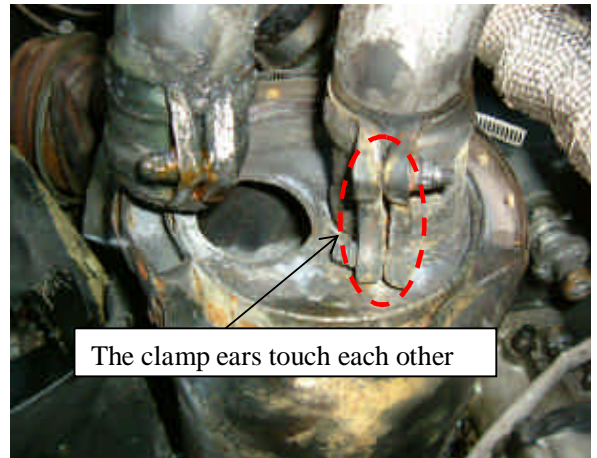
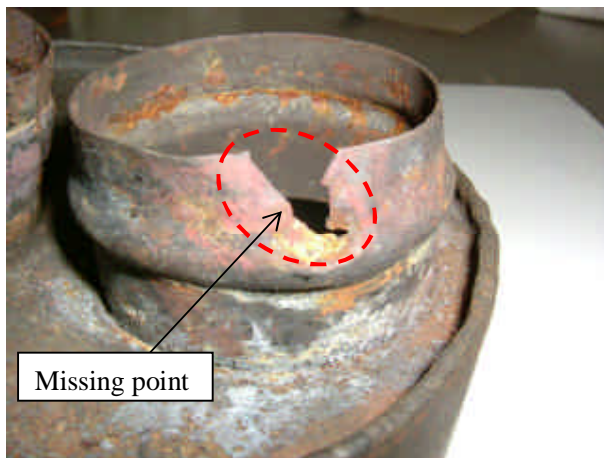
### Photo 7 Fracture Surface of the Connecting Pipe



## Photo 8 – Connecting Pipes and Clamps (1)

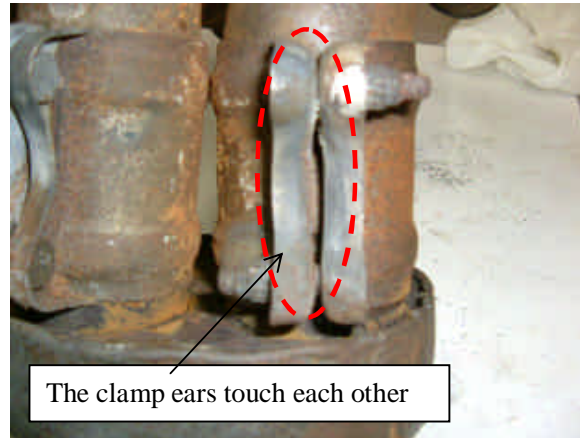
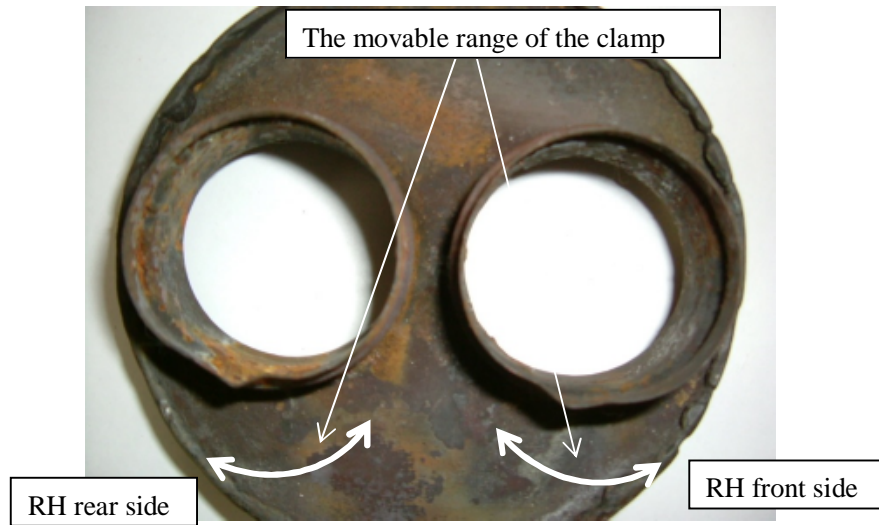


LH front connection pipe and the state of the clamp

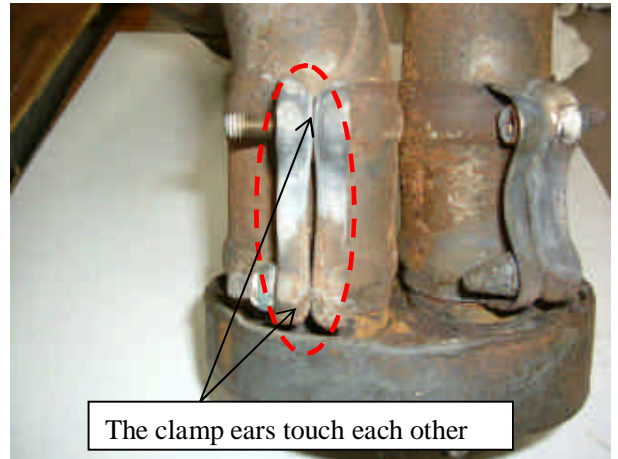


LH rear connecting pipe and the state of the clamp

## Photo 8 Connecting Pipes and Clamps (2)

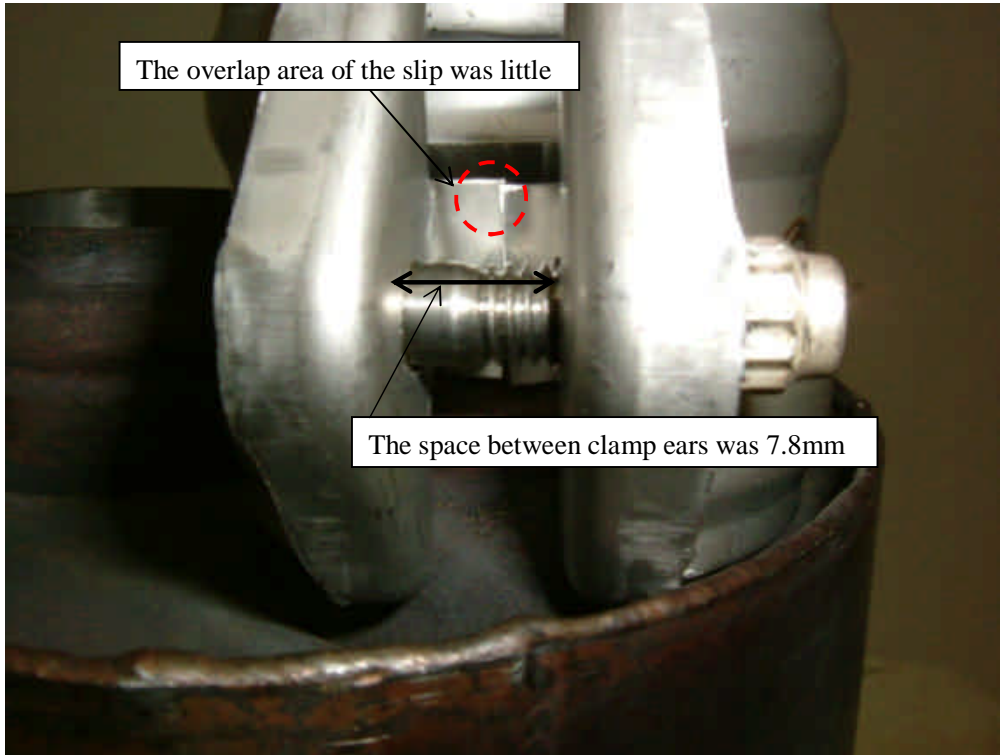


Right front connection pipe and the state of the clamp

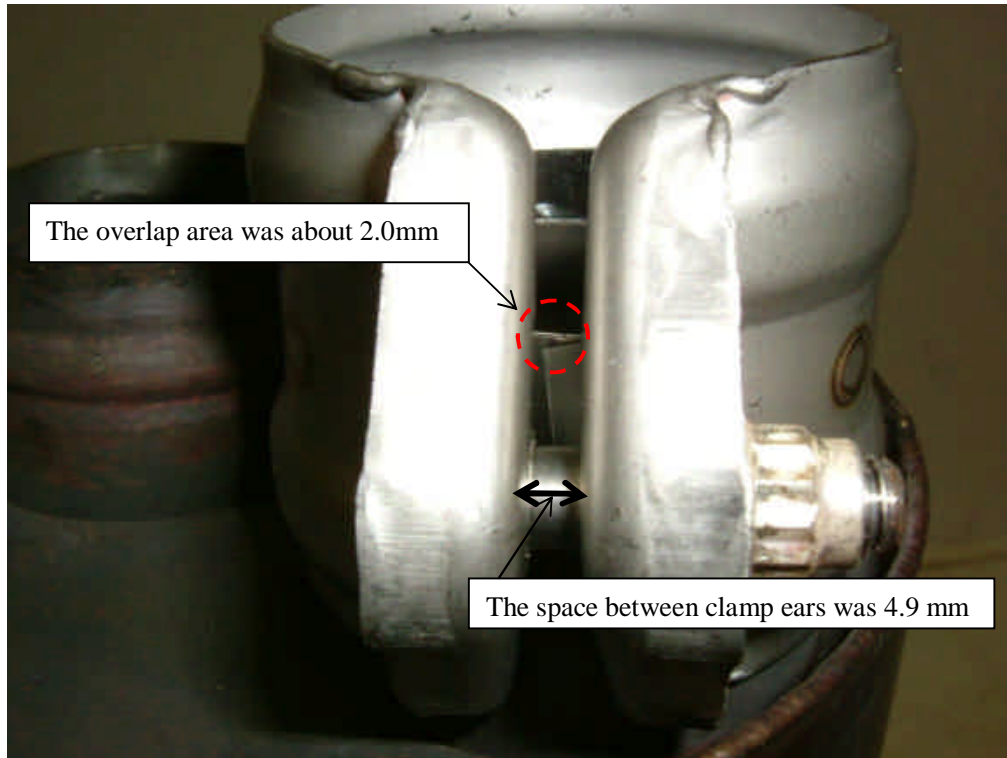


RH rear connecting pipe and the state of the clamp

### Photo 9 Examination Using a New Clamp (1)



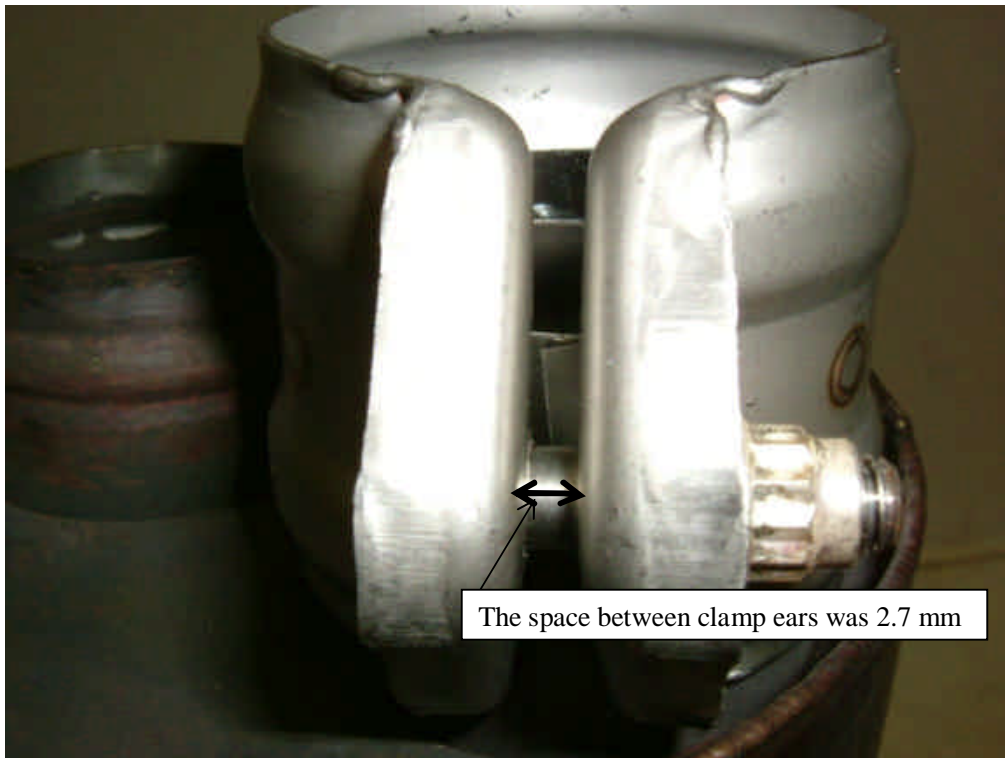
In case of temporarily fitted clamp.



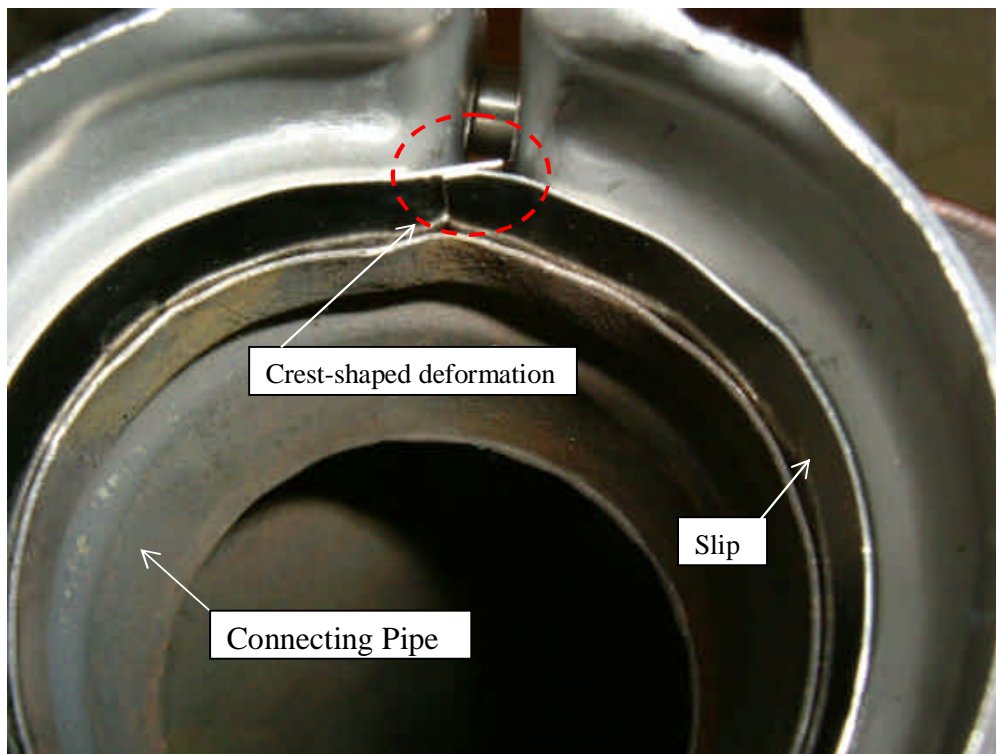
In case of tightened the clamp to set the overlap area about 2.0mm.



### Photo 9 Examination Using a New Clamp (2)



In case of tightened the clamp to deform the Connecting Pipe.



The condition of deformation of the Connecting Pipe

### Photo 10 Deteriorated Weld (Inside)



Exhaust Pipe left side

