

AA2018-6

**AIRCRAFT ACCIDENT
INVESTIGATION REPORT**

**PRIVATELY OWNED
JA3989**

August 30, 2018

The objective of the investigation conducted by the Japan Transport Safety Board in accordance with the Act for Establishment of the Japan Transport Safety Board and with Annex 13 to the Convention on International Civil Aviation is to determine the causes of an accident and damage incidental to such an accident, thereby preventing future accidents and reducing damage. It is not the purpose of the investigation to apportion blame or liability.

Kazuhiro Nakahashi

Chairman

Japan Transport Safety Board

Note:

This report is a translation of the Japanese original investigation report. The text in Japanese shall prevail in the interpretation of the report.

AIRCRAFT ACCIDENT INVESTIGATION REPORT

CRASH INTO THE VICINITY OF THE MOUNTAINTOP

NEW CENTRAL AIRSERVICE CO., LTD.

CESSNA 172P, JA3989

ASHIKURAJI, TATEYAMA TOWN, NAKANIKAWA DISTRICT,

TOYAMA PREFECTURE, JAPAN

AT AROUND 14:50 JST, JUNE 3, 2017

August 10, 2018

Adopted by the Japan Transport Safety Board

Chairman Kazuhiro Nakahashi

Member Toru Miyashita

Member Toshiyuki Ishikawa

Member Yuichi Marui

Member Keiji Tanaka

Member Miwa Nakanishi

SYNOPSIS

<Summary of the Accident>

On Saturday, June 3, 2017, a Cessna 172P, registered JA3989, operated by New Central Airservice Co.,Ltd., took off from Toyama Airport, while flying to Matsumoto Airport, at around 14:50 Japan Standard Time (JST: UTC+9 hours, unless otherwise stated all times are indicated in JST), it crashed into the vicinity of the top of Mt. Shishi-dake (elevation about 2,700 m) in the Tateyama Mountain Range.

There were four people on board the Aircraft consisting of a PIC, a pilot and two passengers and all of them were fatally injured.

The aircraft was destroyed but there was no outbreak of fire.

<Probable Cause>

It is probable that as the Aircraft got into clouds during VFR flight over the mountain region, it became difficult for the PIC and the Pilot to grasp its own position and surroundings by confirming visually the terrain, then, the Aircraft approached the vicinity of the mountaintop and crashed into it.

It is somewhat likely that the Aircraft approached the vicinity of the mountaintop and crashed into it due to loss of visual contacts making the crash unavoidable, or due to failure to maintain minimum safe altitude caused by the Aircraft icing or stalled condition, or due to encountering a severe turbulence. However, it could not be determined, since the PIC and all members on board were fatally injured.

Concerning the fact that the Aircraft came to fly into clouds, it is probable that the PIC and the Pilot had not confirmed thoroughly the weather forecast for the mountainous region before departure and they delayed in making a decision to turn back during flight.

<Recommendations>

Recommendations for the Minister of Land, Infrastructure, Transport and Tourism

In this accident, it is probable that as the Aircraft got into clouds during VFR flight over the mountain region, it became difficult for the Aircraft to grasp its own position and the surroundings by confirming visually the terrain, then, the Aircraft approached the vicinity of the mountaintop and crashed into it.

It is somewhat likely that the Aircraft approached the vicinity of the mountaintop and crashed into it due to loss of visual contacts making the crash unavoidable, or due to failure to maintain minimum safe altitude caused by the Aircraft icing or stalled condition, or due to encountering a severe turbulence. Concerning the fact that the Aircraft came to fly into clouds, it is probable that the PIC and the Pilot had not confirmed thoroughly the weather forecast for the mountainous region before departure and they delayed in making a decision to turn back during flight.

In view of the result of this accident investigation, the Japan Transport Safety Board recommends pursuant to the provision of Article 26 of the Act for Establishment of the Japan Transport Safety Board that the Minister of Land, Infrastructure, Transport and Tourism should take the following measures in order to prevent the aircraft accidents and reduce damage from those when they occur.

- (1) Make it known to pilots that the icing conditions are extremely hazardous for the aircraft not certificated for flight in icing conditions and those aircraft should definitely avoid flying in icing conditions.
- (2) Encourage pilots for small airplanes to fasten their seat belts and shoulder harnesses and instruct them to ask their passengers to fasten their seat belts.
- (3) Provide small aircraft users with the information on the appropriate installation and operation of the ELTs.
- (4) Request relevant organizations to ensure that each search and rescue (SAR) aircraft during SAR operation shall be able to precisely listen on the distress frequencies.

The main abbreviations used in this report are as follows:

ADF: Automatic Direction Finder
AIP: Aeronautical Information Publication
ARSR: Air Route Surveillance Radar
ELT: Emergency Locator Transmitter
GPS: Global Positioning System
IAS: Indicated Airspeed
ICAO: International Civil Aviation Organization
IMC: Instrument Meteorological Conditions
LWC: Liquid Water Content
PIC: Pilot In Command
POH: Pilot's Operating Handbook
RCC: Rescue Coordination Center
TAS: True Airspeed
VFR: Visual Flight Rules
VMC: Visual Meteorological Conditions

Unit Conversion List:

1 kt: 1.852 km/h (0.5144 m/s)
1 nm: 1,852 m
1 ft: 0.3048 m
1 in: 25.40 mm
1 lb: 0.4536 kg

TABLE OF CONTENTS

1	PROCESS AND PROGRESS OF THE INVESTIGATION.....	1
1.1	Summary of the Accident	1
1.2	Outline of the Accident Investigation.....	1
1.2.1	Investigation Organization.....	1
1.2.2	Representatives of the Relevant State.....	1
1.2.3	Implementation of the Investigation	1
1.2.4	Comments from the Parties Relevant to the Cause of the Accident.....	1
1.2.5	Comments from the Relevant State	2
2	FACTUAL INFORMATION.....	2
2.1	History of the Flight	2
2.1.1	History of the Flight and Situation after the Accident.....	2
2.1.2	Statements of Relevant Persons.....	4
2.2	Injuries to Peoples	6
2.3	Damage to the Aircraft.....	6
2.3.1	Extent of Damage	6
2.3.2	Damage to the Aircraft Components.....	6
2.4	Personnel Information.....	7
2.5	Aircraft Information	7
2.5.1	Aircraft	7
2.5.2	Engine.....	8
2.5.3	Weight and Balance.....	8
2.5.4	Fuel and Lubricating Oil.....	8
2.6	Meteorological Information.....	8
2.6.1	Meteorological Conditions at Airports	8
2.6.2	Meteorological Conditions along the Flight Route.....	9
2.7	Information on Accident Site and the Aircraft	16
2.7.1	Situation of Accident Site.....	16
2.7.2	Situation of the Aircraft	17
2.7.3	Detailed Situation of Damage.....	18
2.8	Medical Information	20
2.9	Information on Communication.....	20
2.10	Information on Search and Rescue (SAR) Operation.....	20
2.10.1	Situation in SAR Operations	20
2.10.2	Convention on International Civil Aviation (ICAO) Rules	21
2.10.3	Information on Seats and Seatbelts.....	22
2.11	Records on the ARSR.....	22
2.12	Rules of the Civil Aeronautics Act	23
2.12.1	Visual Meteorological Conditions	23
2.12.2	Minimum Safety Altitude	24
2.13	Rules of the Company.....	24
2.13.1	Decision on Turning Back, Emergency Communication and Others	24
2.13.2	Performance of the Same Type of Aircraft.....	25
2.13.3	Ban on Flight in Icing Conditions	25

2.14	Flight Record of the PIC and the Pilot	26
2.14.1	Flight Record of the PIC	26
2.14.2	Flight Record of the Pilot	27
2.15	Icing	28
2.15.1	Icing Conditions	28
2.15.2	Effects of Icing	29
2.15.3	Icing in Mountain Regions	29
2.16	Mountain Flying	30
2.16.1	Preparations and Precautions for Mountain Flying	30
2.16.2	Turbulence in the Vicinity of the Mountaintop	31
2.17	ELT (Emergency Locator Transmitter)	32
2.17.1	Regulations on ELT	32
2.17.2	The ELT on the Aircraft	32
2.18	Similar Accidents and Incidents	35
2.18.1	Similar Accidents and Incidents in the Past	35
2.18.2	Recommendations in Past Similar Accidents and Incidents	36
2.19	Additional Information	37
2.19.1	Flight Plan Chart	37
2.19.2	The SNS Posting by the Pilot and Photos Taken in the Aircraft	38
2.19.3	J-3 JSDF Training / Testing Areas	40
2.19.4	Altimeter Errors on Mountain Flights	40
2.19.5	Use of Shoulder Harness	40
3	ANALYSIS	41
3.1	Qualification of Personnel	41
3.2	Aircraft Airworthiness Certificate	41
3.3	Relations to the Meteorological Conditions	41
3.4	Judgment before Departure	42
3.4.1	Flight Plan of the Aircraft	42
3.4.2	The Aircraft's Departure Decided by the PIC and the Pilot	42
3.5	History of the Flight	43
3.5.1	Takeoff From Toyama Airport Up To Flying Over the Mountains	43
3.5.2	Flight Situation of the Aircraft after Deciding on Turning Back	44
3.5.3	The Aircraft Sliding Down on Snowy Surface after the Crash	44
3.6	Decisions on Turn Back When Weather Deteriorates Enroute	45
3.7	Icing of the Aircraft	45
3.7.1	Icing Encounter	45
3.7.2	Effects of the Aircraft Icing	46
3.8	Possibility of Encountering Turbulence in the Vicinity of the Mountaintop	46
3.9	Performance of the Aircraft	47
3.10	Healthiness of the Aircraft	47
3.11	Need for Emergency Communication	48
3.12	ELT	48
3.12.1	Operation Status of ELTs and Reception Status of Emergency Communications	48
3.12.2	Instructions on Installation and Operation in the ELT Manufacturer's Manual	49
3.12.3	Appropriate Operation of ELTs	49

3.13	Monitoring of Distress Frequencies by the SAR Aircraft	50
3.14	Instructions and Notification to Pilots Flying under VFR	50
3.14.1	Hazardousness of In-cloud Flight under VFR and Hazardousness of Flight in Icing Conditions	50
3.14.2	Preparations and Precautions for Mountain Flying	51
3.15	Fastening Seat Belt and Shoulder Harness	51
4	CONCLUSIONS	52
4.1	Summary of Analysis	52
4.2	Probable Causes	54
5	SAFETY ACTIONS	54
5.1	Safety Actions Taken by the Company after the Accident	54
5.2	Safety Actions Taken by the Civil Aviation Bureau of the MLIT after the Accident	55
5.3	Safety Actions Required to be Taken	55
5.3.1	Actions Required to be Taken by the Civil Aviation Bureau of the MLIT	55
6	RECOMMENDATIONS	56
6.1	Recommendations for the Minister of Land, Infrastructure, Transport and Tourism	56

1 PROCESS AND PROGRESS OF THE INVESTIGATION

1.1 Summary of the Accident

On Saturday, June 3, 2017, a Cessna 172P, registered JA3989, operated by New Central Airservice Co.,Ltd., took off from Toyama Airport to Matsumoto Airport. At around 14:50 Japan Standard Time (JST: UTC+9 hrs, unless otherwise stated all times are indicated in JST), it crashed into the vicinity of the top of Mt. Shishi-dake (elevation about 2,700 m) in the Tateyama Mountain Range.

There were four people on board the aircraft consisting of a PIC, a pilot and two passengers and all of them were fatally injured.

The aircraft was destroyed but there was no outbreak of fire.

1.2 Outline of the Accident Investigation

1.2.1 Investigation Organization

On June 4, 2017, the Japan Transport Safety Board (JTSB) designated an investigator-in-charge and an investigator to investigate this accident. After that, JTSB designated three more investigators.

1.2.2 Representatives of the Relevant State

An accredited representative and an adviser of the United States of America, as the State of Design and Manufacture of the aircraft involved in this accident, participated in the investigation.

1.2.3 Implementation of the Investigation

June 4, 2017	Interviews and examination of data and information
June 5, 2017	On-site investigation, confirmation of articles left on the scene and interviews
June 6, 2017	Interviews
June 13, 2017	On-site investigation
June 14, 2017	Interviews
June 15, 2017	Interviews
July 6, 2017	On-site investigation
July 13 to 19, 2017	Airframe examination
August 8, 2017	Data downloading from the ELT
August 9, 2017	Examination of meteorological information based on numerical analysis
September 30 to	Examination of propellers
November 16, 2017	

1.2.4 Comments from the Parties Relevant to the Cause of the Accident

Comments were invited from parties relevant to the cause of the accident.

1.2.5 Comments from the Relevant State

Comments were invited from the Relevant State.

2 FACTUAL INFORMATION

2.1 History of the Flight

In the morning of June 3, a Cessna 172P, registered JA3989 (herein after referred to as “the Aircraft”), operated by New Central Airservice Co., Ltd. (hereinafter referred to as “the Company”) took from Matsumoto Airport and flew to Toyama Airport via Omachi City, Itoigawa City and Uozu City. At 14:23, the Aircraft took off from Toyama Airport for Matsumoto Airport. The four persons on board were seated as follows: an Pilot-in-Command (hereinafter referred to as “PIC”) of the Company in the right front seat, a pilot, other flight crew member (hereinafter referred to as “the Pilot”) in the left front seat, one passenger in the right aft seat (hereinafter referred to as “Passenger A”) and another passenger in the left aft seat (hereinafter referred to as “Passenger B”).

The flight plan of the Aircraft submitted by the PIC in the morning of the day of the accident is outlined below: (See Appended Figure 1: Estimated Flight Route (1))

Flight rules: Visual Flight Rules (VFR)

Departure aerodrome: Toyama Airport

Estimated block-out time: 14:30

Cruising speed (TAS¹): 95 kt

Cruising altitude: VFR²

Route: Kamidaki – Murodo – Omachi

Destination aerodrome: Matsumoto Airport

Total estimated elapsed time: One hour

Fuel load expressed in endurance: Four hours

Peoples on Board: Four

Purpose of flight: Flight training for aerial work services³

PIC⁴: the PIC⁵

The history of the flight up to the time of the accident is summarized as below according to the Air-Ground communication records, the air traffic control records, and radar track records of Air Route Surveillance Radar (hereinafter referred to as “ASAR⁶”), the photos found in Passenger A’s smartphone, as well as the statements of relevant person.

2.1.1 History of the Flight and Situation after the Accident

Saturday, June 3

Around 08:00 The PIC (the Company’s member) and the Pilot (the Company’s Customer)

¹ “TAS” stands for True Airspeed, which is calculated by adding position error, instrument error and air density correction to Indicated Airspeed (IAS).

² “VFR” means the visual flight rules.

³ The “aerial work services” means the paid aircraft flight services other than the air transport service of passengers and cargo. Those services, which are provided according to customers’ requests, include such as sightseeing flights and aerial photo missions.

⁴ “PIC” stands for Pilot In Command who is the person in charge of captain’s duty.

⁵ In the submitted flight plan, PIC’s name was put as the PIC of the Aircraft.

⁶ For “ARSR”, see 2.11.

arrived at the Company's Matsumoto office (hereinafter referred to as "Matsumoto Office").

Around 08:20 A mechanic of Matsumoto Office (hereinafter referred to as "Mechanic A") made an inspection to confirm the Aircraft's condition before its flight.

09:28 The Aircraft took off from Matsumoto Airport.

10:35 The Aircraft arrived at Toyama Airport

14:23 The Aircraft took off from Runway 02, Toyama Airport. The ARSR commenced to receive transponder response signals sent from the Aircraft on VFR flight⁷ which took off from Toyama Airport.

14:28 The Aircraft informed the local controller at the Toyama Airport Traffic Control Tower (hereinafter referred to as "Toyama Tower") about its position and altitude, reporting that it would leave Toyama Airport Control Zone.

Around 14:35 The Aircraft repeatedly made a left turn to 360° climb.

Around 14:40 The Aircraft crossed the Tateyama Mountain Range and flew into the area over Lake Kurobe.

Around 14:45 The Aircraft flew at a certain altitude but often changed heading.

Around 14:50 The transponder signal from the Aircraft was lost in the vicinity of Mt. Shishi-dake of the Tateyama Mountain Range.

Around 14:51 The Matsumoto Office received a phone call from a portable phone belonging to the PIC (hereafter referred to as "PIC's portable").

15:02 The Toyama Prefectural Police Headquarters (hereinafter referred to as "the Prefectural Police") received the emergency call on the Aircraft crash.

15:15 Matsumoto Airport informed the Tokyo Rescue Coordination Center (hereinafter referred to as "RCC") about information on the Aircraft.

Around 15:20 The Matsumoto Office got a call from PIC's portable and Mechanic A advised to switch on the Emergency Locator Transmitter⁸ (hereinafter referred to as "ELT"), which was installed in the Aircraft.

15:40 to The Matsumoto office received several calls from PIC's portable.

16:25 A Helicopter of the Prefectural Police (hereinafter referred to as "Police Helicopter") took off from Toyama Airport for search and rescue operations.

16:56 The Commander in Chief of the Central Air Defense Force of the Japan Air Self-Defense Forces, Ministry of Defense started the search and rescue operations for life-saving at the request of the RCC.

17:50 Due to bad weather, the Prefectural Police suspended the search and rescue operations of the day.

Sunday, June 4

04:38 The Police Helicopter took off from Toyama Airport

05:01 The Police Helicopter spotted a small aircraft which seemed like the Aircraft on a southeast mountain slope of Mt. Shishi-dake in the Tateyama

⁷ The "Aircraft on VFR flight" means a flying aircraft under Visual Flight Routes.

⁸ The "Emergency Locator Transmitter (ELT) is a radio communication equipment that emits a distress signal in case of distress, a crash and forced landing to help locating the distress / forced landing site. It is required to equip with the number of emergency locator transmitters (ELTs) in accordance with the classification of the Aircraft. See 2.17.

	Mountain Range.
05:16	The Prefectural Police Mountain Ranger confirmed that all members on board did not respond to his call.
10:15	The Police Helicopter airlifted all four bodies to the Toyama University Hospital.
12:07	All four members on board were confirmed dead.

2.1.2 Statements of Relevant Persons

(1) Director of the Matsumoto Office

The director of the Matsumoto Office (hereinafter referred to as “Director”) did not fully grasp in detail the circumstances up to the accident, but understood that the flight plan of the Aircraft was to return to Matsumoto Airport after full stop-and-go⁹ at Toyama Airport. The Director thought the PIC was on board the Aircraft because the Company has the regulations stipulating that the Company’s pilot shall be on board in case of full stop-and-go. The Director talked about the PIC and the Pilot as follows:

For sightseeing flights and aerial photo missions, the PIC was on board the same type of aircraft (hereinafter referred to as “the Same Aircraft Type) operated by the Company, while regularly engaged in the contracted flight missions operated by other company as a co-pilot for other types of aircraft¹⁰. With a flight instructor certificate, the PIC occasionally supervised the flight as a flight instructor and served as an examination board member of the Pilot Competency Assessment. In addition, the PIC had a valid Instrument Flight Certificate required to fly an aircraft under Instrument Meteorological Conditions¹¹. And the PIC was full of the latest flight experience¹² enough to conduct an instrument flight, and he was an experienced pilot with the total flight time exceeding 17,000 hours. The PIC always performed flight operations cautiously to ensure the safe flights, which enable him to earn customer trust and to have concurrently served as a flight manager in the Company since July 2015.

The Pilot was a member of the Central Airline Club¹³ (hereinafter referred to as “Club Member”) and flew regularly using Matsumoto Airport as its base, occasionally with the PIC after obtaining a Private pilot certificate (hereinafter referred to as “Private License”) in January 2012.

(2) Mechanic A and Office Worker in Matsumoto Office

The 100-hours check for the Aircraft was completed on May 23, 2017. Mechanic A confirmed that no abnormality was found in the Aircraft at the time of the preflight checks conducted on the day of the accident.

⁹ The “full stop-and-go” means making landing and takeoff at the airport other than its base station in an open air flight.

¹⁰ The PIC used to fly Beechcraft B300 (twin - engine turboprop - airplane) in the contracted flight services operated by other company.

¹¹ Instrument Meteorological Conditions (IMC) is a visually bad meteorological conditions other than VMC (Visual Meteorological Conditions) prescribed by the MLIT according to the visibility and cloud conditions. See 2.12.1, for Visual Meteorological Conditions.

¹² In order to conduct an instrument flight, it is required to have instrument flight experience of 6 hours or more within 180 days.

¹³ The Central Airline Club is a group which consists of several pilots who use the aircraft operated by the Company. The activities of club members, including whether there would be the aircraft leasing contract between club members and the Company or not, could not be made clear since the PIC managed those activities in this club in Matsumoto Office.

Mechanic A had known the PIC for nearly 20 years. As occasionally having discussed with the PIC the safety of flight, he considered the PIC as an uncompromising person regarding the safety issues. The Mechanic A heard that the PIC planned to fly via Itoigawa City on the outward journey for Toyama Airport, and to fly over the mountains on the homeward journey for Matsumoto Airport since he had a talk with the PIC on the planned flight route a day before the accident.

On the day of the accident, Mechanic A was watching the Aircraft up to its takeoff at 09:28.

At around 15:00, the Mechanic A got a call from PIC's portable (First call). It was an emergency call by the name of Passenger A asking for help in a steady voice. Mechanic A thought that the Aircraft had crashed, hearing Passenger A saying "Two pilots in the front seats are unconscious but two peoples in the rear seats remain conscious." Asked by Mechanic A exactly where the Aircraft was, Passenger A answered, "Surrounded by all white, I cannot see where we are." Mechanic A told Passenger A to make an emergency call¹⁴ to the police and once hung up the phone. Afterwards, Mechanics A was informed that an office worker in Matsumoto Office (hereinafter referred to as "Office Worker A" had received a call (Second call) from Passenger A saying that he made an emergency call to the police. Mechanics A addressed the next call (Third call) from Passenger A. The Mechanics A requested Passenger A to switch on the ELT radio component installed in the Aircraft, but Passenger A said that he did not see where the ELT radio component was because he was not able to move. The phone was cut off in the middle of this communication.

Office Worker A received the fourth call from Passenger A. Office Worker A made every effort to cheer up Passenger A who talked in a steady voice while making a strong appeal for searching and rescuing them as soon as possible. Although Office Worker A did not catch the voice of Passenger B, it seemed to him that the two passengers were encouraging each other. There were several calls incoming from PIC's portable subsequently, but they were soon hung up.

(3) Toyama Tower and Operation Staff of Toyama Airport Flight Operation Support

At 14:23, the Aircraft took off from Runway 02. Toyama Tower monitored that the Aircraft left Toyama Area Control Zone at an altitude of 3,000 ft and at around 5 nm east to Toyama Airport and instructed the Aircraft to make frequency change. As the east side of the Airport was covered with clouds at an altitude of about 2,500 to 3,000 ft, the Aircraft seemed to be heading to the east while avoiding the clouds. At around 14:42, Toyama Tower confirmed the position of the Aircraft and found it still at an altitude of around 8,000 ft and at 19 nm east to the Airport, assuming that the Aircraft would try to gain altitude to cross the mountains. Toyama tower thought that the Aircraft would fly through rifts of cloud, since it was cloudy in the mountains and there was cloud on the mountaintop this day.

In addition, according to an operation staff of the Toyama Airport Flight Operation Support ¹⁵, in the afternoon of the day of the accident, a pilot visited the office of the Toyama Airport Flight Operation Support. The operation staff remembered that the pilot was using the terminal for meteorological information for about ten minutes and the signature by the PIC was put in the record (13:05).

(4) Other Members of Club.

The club members have had contact with the PIC and have known the Pilot as well. They knew

¹⁴ The Toyama Prefectural Police Headquarters received an emergency call from Passenger A at 15:02.

¹⁵ "An operation staff of the Toyama Airport Flight Operation Support" is a staff member of a contracting private company to support the aircraft operation at Toyama Airport.

that the PIC was in charge of education/training as a flight instructor and The Pilot was his student.

Club members understood that the PIC worked at an issue of the safety of flight in a very cautious manner and paid careful attention to the change of meteorological conditions. For example, in mountain flying, he was such a pilot as would not fly the east side of the mountain when the westerly wind was strong. Therefore, they could not believe that the PIC tried to fly and cross the mountain under the bad weather condition and crashed into the vicinity of the mountaintop.

A club member, who had experiences with a reduced flight altitude caused by mountain waves and with a temporary failure of the altimeter indicator on mountain flying, estimated that it would be difficult for the same type of aircraft to cross the Tateyama Mountain Range, since its engine does not have enough horsepower to carry four occupants on board.

(5) Other Pilot who was flying over the Nanshin Region, Nagano Prefecture

The pilot was flying over the Nanshin region, Nagano prefecture once in the morning and twice in the afternoon on the day of the accident. He thought that it would be difficult to fly over the Tateyama Mountain Range, the accident site where there were many clouds. In addition, he thought that it would be impossible for him to fly the same type of light aircraft as the Aircraft with four occupants on board even if it is a fine weather.

(6) Photographer who had asked the PIC to fly for aerial photo mission

It had been five years since the Photographer started asking the PIC to fly for aerial photo missions. When asking the PIC to fly over the mountainous region at a low altitude, he had been refused by the PIC explaining about the possible turbulence. Therefore, he considered the PIC as a reliable pilot who would pay close attention to the safety of flight.

Besides, the Photographer thought that the PIC totally knew the topographic aspect around the accident site, since he often used to ask the PIC to fly over the Tateyama Mountain Range for aerial photo mission.

The accident occurred in the vicinity of Ashikuraji, Tateyama town, Nakaniwa district, Toyama prefecture (the southeastern slope in the vicinity of the top of Mt. Shishi-dake): 36° 33' 08" N, 137° 36' 22" E), at the time of around 14:50, on June 3, 2017. (See Appended Figure 1: Estimated Flight Route (1), Appended Figure 2: Estimated Flight Route (2), Appended Figure 4: Estimated Flight Route (4) and Appended Figure 5: The Site of the Accident)

2.2 Injuries to Peoples

A PIC, a pilot, Passenger A and Passenger B on board the aircraft and all members fatally injured.

2.3 Damage to the Aircraft

2.3.1 Extent of Damage

Destroyed

2.3.2 Damage to the Aircraft Components

- | | |
|---------------|--------|
| (1) Fuselage | Broken |
| (2) Wing | Broken |
| (3) Empennage | Broken |

- (4) Engine Broken, detached from the fuselage
- (5) Propeller Damaged
- (6) Landing gears Broken, detached from the fuselage

(See Appended Figure 6: Estimated Crash Site, Marks and Traces, Appended Figure 7: The Site of Spotting the Aircraft, and Appended Figure 8: The Aircraft Found at the Accident Site)

2.4 Personnel Information

- (1) PIC Male, Age 57
 - Commercial pilot certificate (Airplane)
 - Rating for Single-engine (land) April 14, 1981
 - Rating for Multiple-engine (land) June 14, 2002
 - Specific pilot competence review/certificate
 - Expiration date September 27, 2018
 - Instrument flight certificate May 25, 2004
 - Flight instructor certificate August 30, 1985
 - Class 1 aviation medical certificate
 - Validity April 23, 2018
 - Total flight time 17,127 hours 35 minutes
 - Flight time in the last 30 days 28 hours 30 minutes
 - Total flight time on the same type of aircraft 12,518 hours 57 minutes
 - Flight time in the last 30 days 21 hours 47 minutes

- (2) The Pilot Male, Age 48
 - Private pilot certificate (Airplane)
 - Rating for Single-engine (land) January 23, 2012
 - Specific pilot competence review/certificate
 - Expiration date March 13, 2018
 - Class 2 aviation medical certificate
 - Validity February 14, 2019
 - Total flight time 245 hours 25 minutes
 - Flight time in the last 30 days 0 hours 54 minutes
 - Total flight time on the same type of aircraft 245 hours 25 minutes
 - Flight time in the last 30 days 0 hours 54 minutes

2.5 Aircraft Information

2.5.1 Aircraft

- Type Cessna 172P
- Serial number 17276542
- Date of manufacture September 12, 1994
- Certificate of airworthiness No. TOU-28-451
 - Validity January 17, 2018
- Category of airworthiness Airplane, Normal N
- Total flight time 9,492 hours 11 minutes
- Flight time since last periodical check (100h Check on May 23, 2017) 7 hours 33 minutes

(See Appended Figure 13: Three Angle View of Cessna 172P)

2.5.2 Engine

Type	Lycoming O-320-D2J
Serial number	RL-9115-39E
Total flight time	2,480 hours 43 minutes
Date of overhaul	December 21, 2014
Total flight time since overhaul	754 hours 31 minutes

2.5.3 Weight and Balance

When the accident occurred, the Aircraft's weight was estimated to have been 2,313 lb and the center of gravity (CG) was estimated to have been 44.5 in. aft of the reference point. Both of them were estimated to have been within the allowable range (maximum takeoff weight of 2,400 lb and CG range¹⁶ of 38.6 to 47.3 in) through all the flight process at the time of the accident.

2.5.4 Fuel and Lubricating Oil

The fuel was Aviation Gasoline 100LL and the lubricating oil was Exxon 20W-50.

2.6 Meteorological Information

2.6.1 Meteorological Conditions at Airports

The meteorological observations reported at regular time on the day of the accident at Toyama Airport and Matsumoto Airport were as follows:

Toyama Airport

14:00	Wind direction:	320°	
	Wind speed:	4 kt	
	Directional fluctuation:	260° - 020°	
	Prevailing visibility:	10 km or more	
	Cloud: Amount: FEW ¹⁷ ,	Type: Cumulus,	Cloud base: 2,000 ft
	Amount: SCT ¹⁸ ,	Type: Stratocumulus,	Cloud base: 2,500 ft
	Amount: BKN ¹⁹ ,	Type: Altocumulus,	Cloud base: 10,000 ft
	Temperature:	17°C	
	Dew-point:	10°C	
	QNH:	29.75 inHg	
15:00	Wind direction:	Variable	
	Wind speed:	2 kt	
	Prevailing visibility:	10 km or more	
	Cloud: Amount: FEW,	Type: Cumulus,	Cloud base: 2,000 ft
	Amount: SCT,	Type: Stratocumulus,	Cloud base: 3,000 ft
	Amount: BKN,	Type: Altocumulus,	Cloud base: 10,000 ft

¹⁶ The reference point for the center of gravity (CG) is the lower part of engine fire wall, and the value indicates the distance (inch) backward from this reference point.

¹⁷ "FEW" refer to the apparent cloud cover percentage of the cloudy section against the unobstructed sky is 1/8 ~2/8.

¹⁸ "SCT" refer to the apparent cloud cover percentage of the cloudy section against the unobstructed sky is 3/8 ~4/8.

¹⁹ "BKN" (broken) means a situation in which the visible proportion of areas covered with clouds to the entire skies is 5/8 to 7/8.

Temperature:	17°C
Dew-point:	10°C
QNH:	29.75 inHg

Matsumoto Airport

14:00	Wind direction:	340°	
	Wind speed:	15 kt	
	Prevailing visibility:	50 km or more	
	Cloud: Amount: FEW,	Type: Cumulus,	Cloud base: 5,000 ft
	Amount: SCT,	Type: Stratocumulus,	Cloud base: 8,000 ft
	Amount: BKN,	Type: Altocumulus,	Cloud base: 10,000 ft
	Temperature:	19°C	
	Dew-point:	6°C	
	QNH:	29.62 inHg	
15:00	Wind direction:	360°	
	Wind speed:	12 kt	
	Prevailing visibility:	50 km	
	Cloud: Amount: FEW,	Type: Cumulus,	Cloud base: 5,000 ft
	Temperature:	19°C	
	Dew-point:	7°C	
	QNH:	29.63 inHg	

2.6.2 Meteorological Conditions along the Flight Route

2.6.2.1 Weather Outlook and Wind Conditions in the Upper Air

According to the Asia Pacific Surface Analysis Chart (ASAS) issued at 15:00, June 3 shown in Appended Figure 9, the weather outlook was as follows:

The high-atmospheric pressure system in the North China was moving slowly toward the Yellow Sea and the low-atmospheric pressure system located east of the Tsugaru Straits was moving eastward slowly.

According to the 700 hPa (about 3,000 m) upper analysis chart²⁰ shown in Appended Figure 10, at 09:00 on June 3, the wind was from the west-northwest direction at about 30 kt at over Wajima town, Ishikawa prefecture. Besides, according to Appended Figure 11 indicating the Hourly-Analysis Chart for an altitude of 9,000 ft (about 2,745 m), the wind was from the west-northwest at about 30 kt over the Tateyama Mountain Range in the vicinity of the accident site.

2.6.2.2 Live Camera Images (Distant View of the Tateyama Mountain Range)

The distant view of the Tateyama Mountain Range was confirmed with the images taken by the live camera at Tateyama Town Hall (at the Position A in Figure 1), which is located 30 km west north-west of the Aircraft crash site on Mt. Shishi-dake in the Tateyama Mountain Range in Nakaniwa district, Toyama prefecture. The mountain ridges in the Mt. Oyama, Mt. Ryuuou-dake and Mt. Shishi-dake areas could be visually confirmed all day of the accident, however, the vicinity of the mountaintop was covered with the cumulus-like cloud during the

²⁰ The 700 hPa upper analysis chart shows atmospheric conditions at an altitude of about 3,000 m (10,000 ft)

time period when the accident occurred, and there did not seem to be any space between the mountaintop and the cloud base as shown in Photo 1.

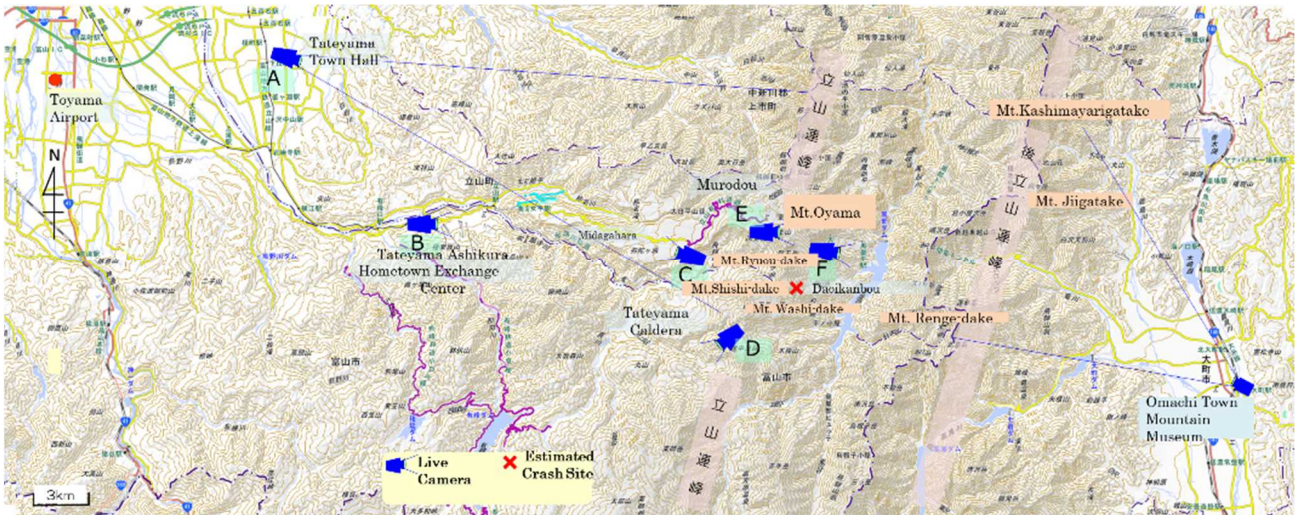

Figure 1: Installation Location of Live Cameras

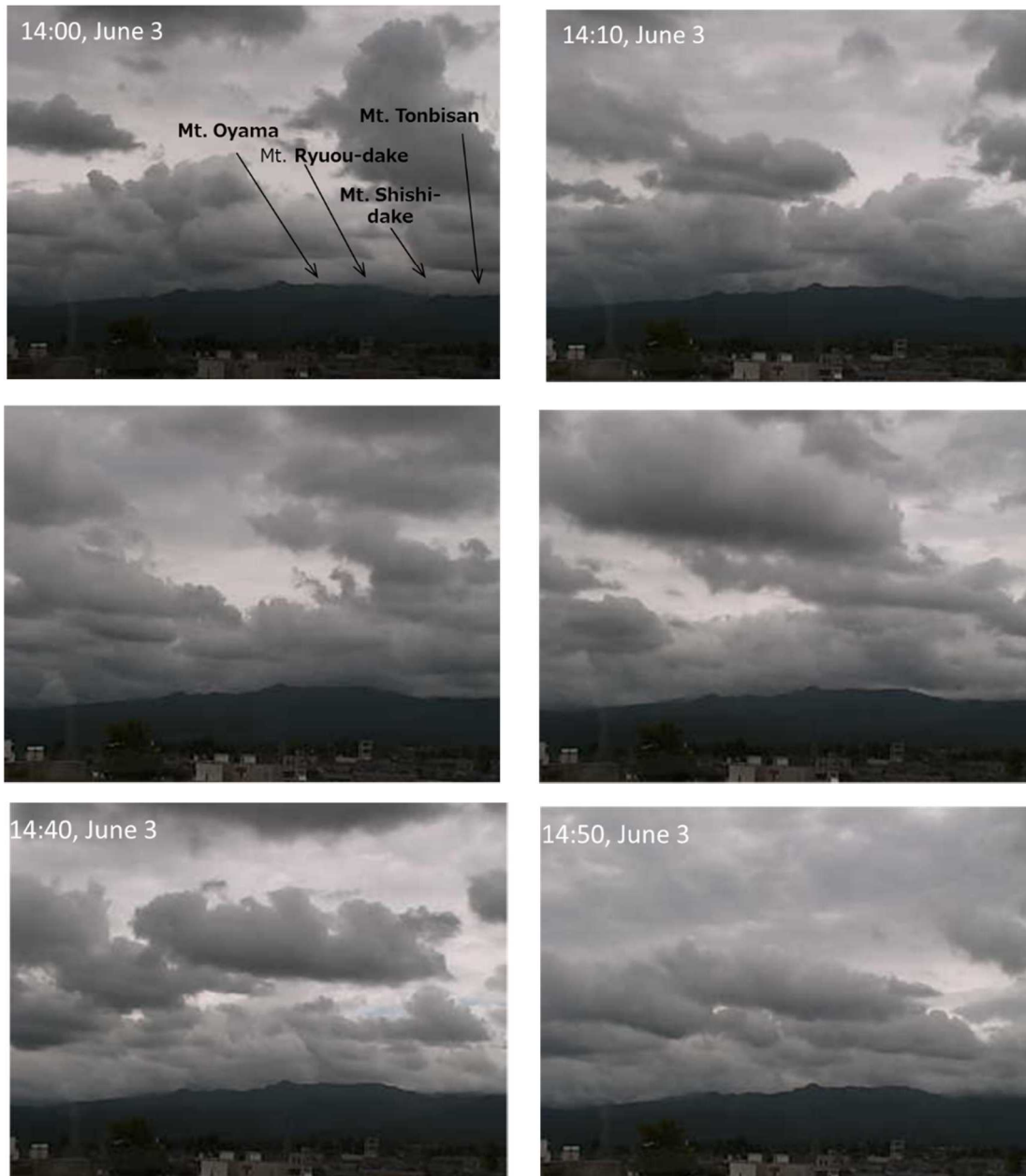

Photo 1: Images of the Tateyama Mountain Range taken by the Live Camera at Tateyama Town Hall (Position A in Figure 1)



Photo 2: Images of the Tateyama Mountain Range taken by the Live Camera at Tateyama Ashikura Hometown Exchange Center (Position B in Figure 1)

It was confirmed that the Tateyama Mountain Range, Midagahara and the Tateyama Caldera²¹ were covered with clouds during the time period when the accident occurred by checking the live camera images in Photo 2 (taken at Tateyama Ashikura Hometown Exchange Center: Position B in Figure 1), those of Midagahara in Photo 3 (taken at Midagahara at an elevation of about 2,300 m: Position C in Figure 1), and the live camera images of the Tateyama Caldera in Photo 4 (taken at the Tateyama Caldera Observatory at an elevation of about 2,015 m: Position D in Figure 1), respectively.



Photo 3: Images taken by the Live Camera at Midagahara (Position C in Figure 1)

²¹ See Appended Figure 3 and 2.7.1.1 for “Tateyama Caldera”.

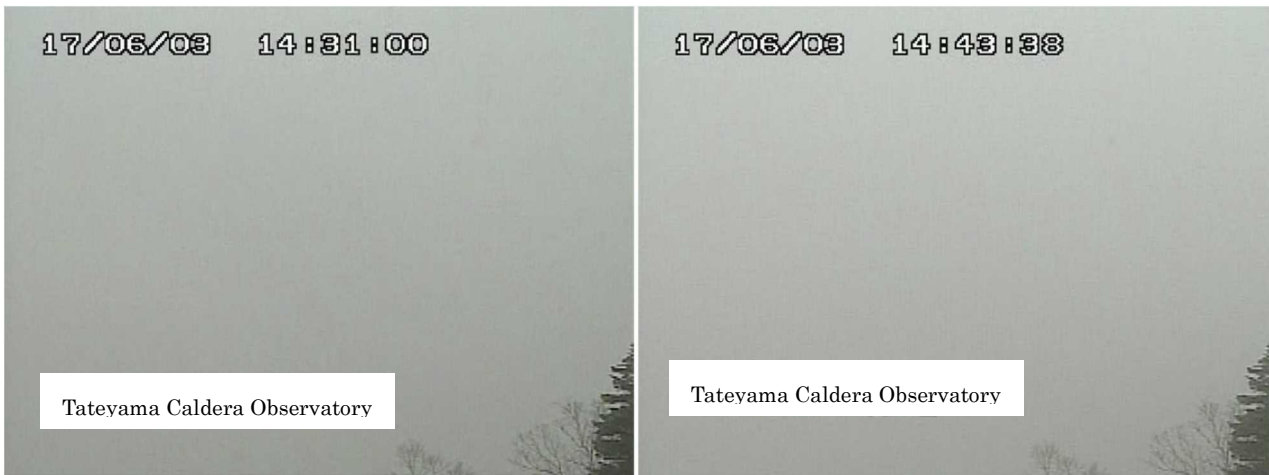

Photo 4: Images taken by the Live Camera
at the Tateyama Caldera Observatory (Position D in Figure 1)

2.6.2.3 Live Camera Image (In the Tateyama Mountain Range)

With Photo 5 showing the images taken by the live camera at Murodo at an elevation of about 2,450 m (Position E in Figure 1), it was confirmed that the weather conditions in the Tateyama Mountain Range were good in the morning of the day of the accident, however, in the afternoon, clouds were gradually generated and clouds filled the entire screen during almost all the time including the time when the accident occurred.



Photo 5: Images taken by the Live Camera
at Murodo (Position E in Figure 1)

Besides, in Photo 6 showing the images taken by the live camera at Daikanbou at an elevation of about 2,316 m (Position F in Figure 1), it was confirmed that the weather conditions in the eastern part of the Tateyama Mountain Range were also good in the morning of the day of the accident, however, visibility rapidly deteriorated in the afternoon.



Photo 6: Images of the eastern part of the Tateyama Mountain Range taken by the Live Camera at Daikanbou (Position F in Figure 1)

2.6.2.4 Live Camera Image (Commanding view of the Ushiroateyama Mountain Range from Omachi Town)

In the images (Photo 7) of the Ushiroateyama Mountain Range²², which consists of Mt. Kashimayarigatake, Mt. Jiigatake and Mt. Renge-dake, taken by the live camera at the Mountain Museum in Omachi City, Nagano Prefecture, it was confirmed that the weather conditions were generally good from 09:00 to 10:00 when the Aircraft flew over Omachi City, however, the mountaintop was covered with the cumulus-like cloud from 13:00 to 15:00.

²² The “Ushiroateyama Mountain Range” is the collective name for the North Alps Mountain Range straddling north and south in parallel with the Tateyama Mountain Range over Lake Kurobe. (See Appended Figure 1 and Figure 1.)

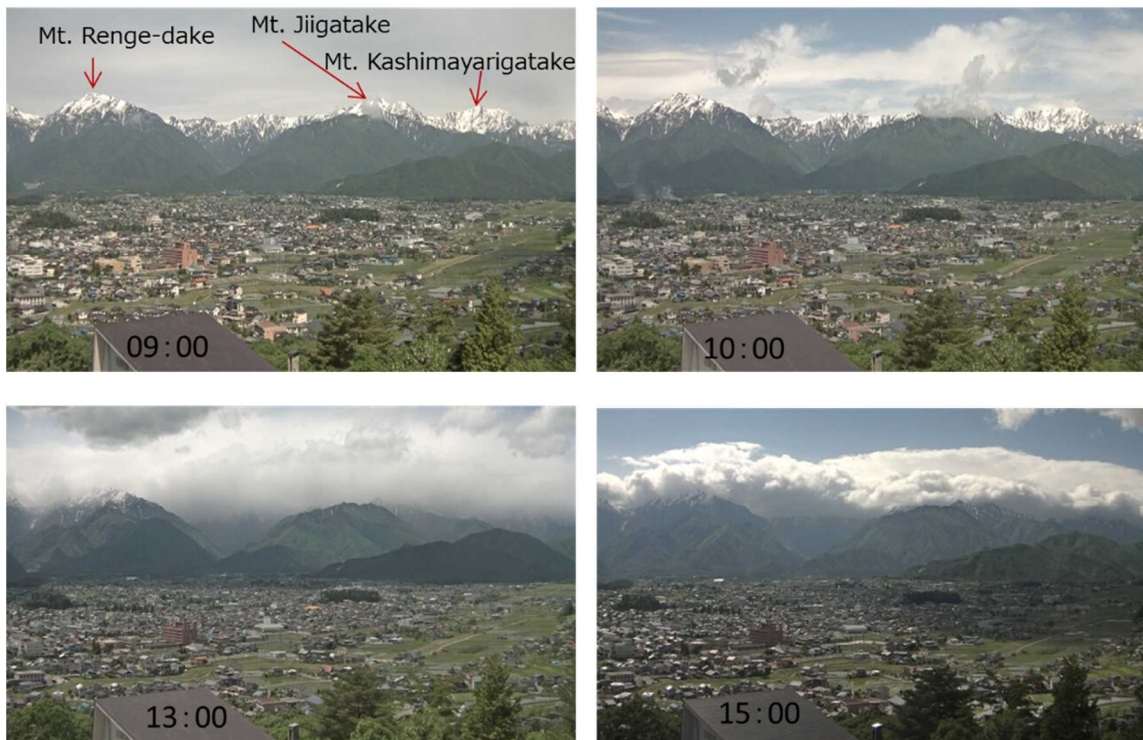

Photo 7: Images of the Ushiroateyama Mountain Range taken by the Live Camera at the Mountain Museum in Omachi Town, Nagano Prefecture

2.6.2.5 Report from a Scheduled Flight Pilot

A scheduled flight pilot, who was flying for Matsumoto Airport during the time period when the accident occurred, reported about the clouds over the Tateyama Mountain Range, which he had seen outside the windows of the cockpit, that the cloud top was about 12,000 ft, the cloud base about 10,000 ft, and the wind direction was 350° and the wind speed was about 35 kt at an altitude of about 10,000 ft.

2.6.2.6 Report from a Motor Glider Pilot

A motor glider pilot, who was flying at an altitude of about 11,000 ft south of the Tateyama Mountain Range during the time period when the accident occurred, remembered that the top of mountains located about 25 km south of the accident site was getting to be covered with clouds and there were many clouds. Besides, the pilot said that although glider pilots can take advantage of the updraft generated by the north west-north wind hitting the Tateyama Mountain Range, he used to be careful not to take a flying course in the leeward side of the mountains where strong downdraft is generated.

2.6.2.7 Temperature Data on the Mountaintop (Mt. Jodosan)

According to the meteorological observation data at the top of Mt. Jodosan²³ located in the vicinity of the accident site, the temperatures²⁴ during the time period when the accident occurred were as follows:

²³ As shown in Appended Figure 4, Mt. Jodosan's elevation is at 9,286 ft (2,831 m) and located about 1.3 km north of Mt. Shishi-dake. The relevant data were observations recorded in the observation device (tower with a height of 8 m) installed on the southern mountaintop of Mt. Jodosan by the Toyama University Science and Engineering Research Institute.

²⁴ The temperatures in the table indicate instantaneous values at every ten minutes.

Table 1: Temperatures at Mt. Jodosan

Time	14:20	14:30	14:40	14:50	15:00
Temperature (°C)	-1.8	-1.6	-1.2	-1.7	-2.3

2.6.2.8 Winds and Clouds Conditions Based on Analysis

In order to confirm the meteorological conditions in the vicinity of the top of the Tateyama Mountain Range during the time period when the accident occurred, we commissioned the Tokai University Research & Information Center to conduct a numerical analysis. In this analysis, the statistical science super computer system in the Institute of Statistical Mathematics was used to create a higher resolution model and visualize it based on the numeric weather prediction model provided by the Japan Meteorological Agency. The result indicated the possibility that north-west wind was blowing at about 30 to 40 kt over the vicinity of the Tateyama Mountain Range at an altitude of about 10,000, and updraft and downdraft caused by that north-west wind might exist in the mountainous region. In addition, as for the humid air areas in the upper air and above the ground, it was shown that the humid air area²⁵ existed in the west side (Tateyama Caldera side) of the Tateyama Mountain Range, but not in the east side (Lake Kurobe side) of it, and there were no remarkable humid air area noted during the time period when the accident occurred. (See Figure 2.) (“+” shown in the following Figure indicates the accident site.)

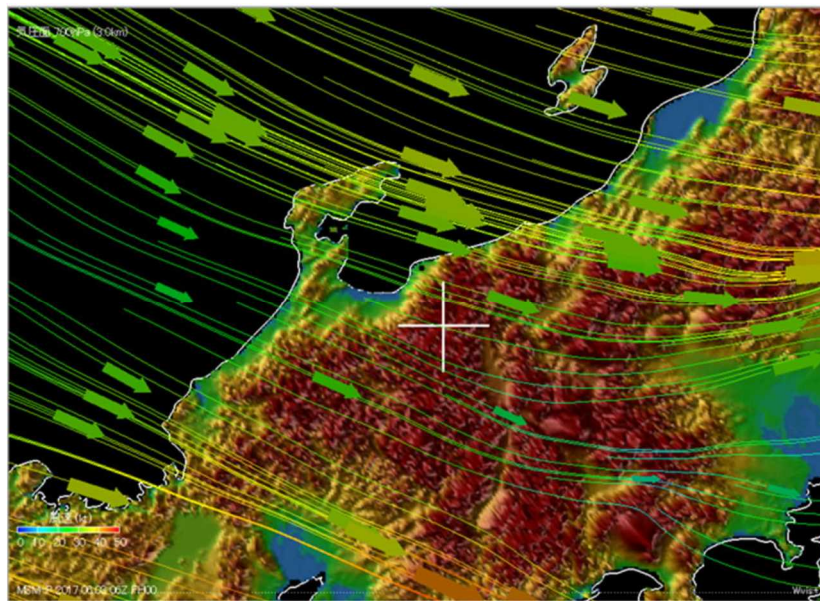

<① Wind Conditions in the Vicinity of the Mountaintop>

²⁵ The humid air area means here the area where the difference between temperature and dew point is less than 1.2 °C and probably it is lower clouds or fogs.

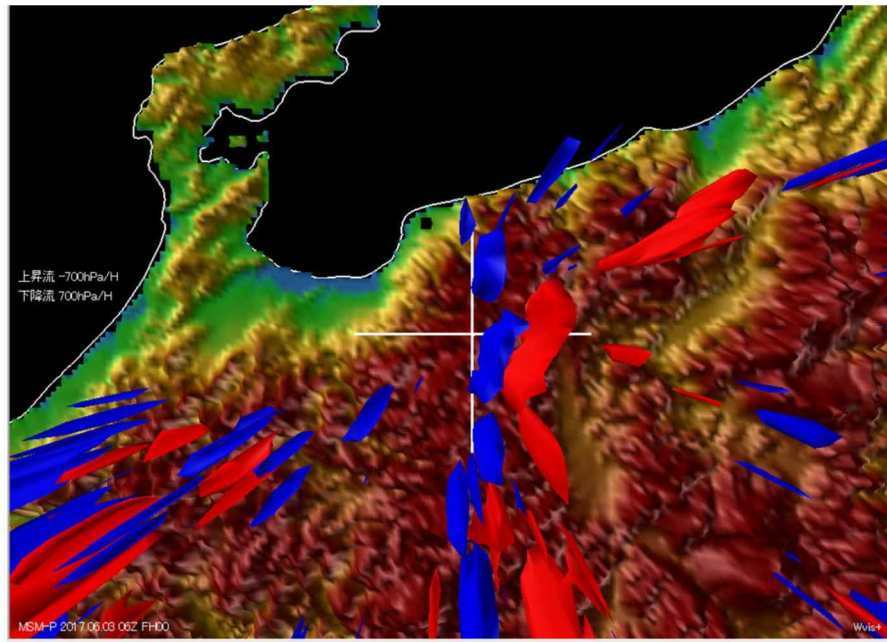

<② Conditions of Updraft (Red) / Downdraft (Blue) >

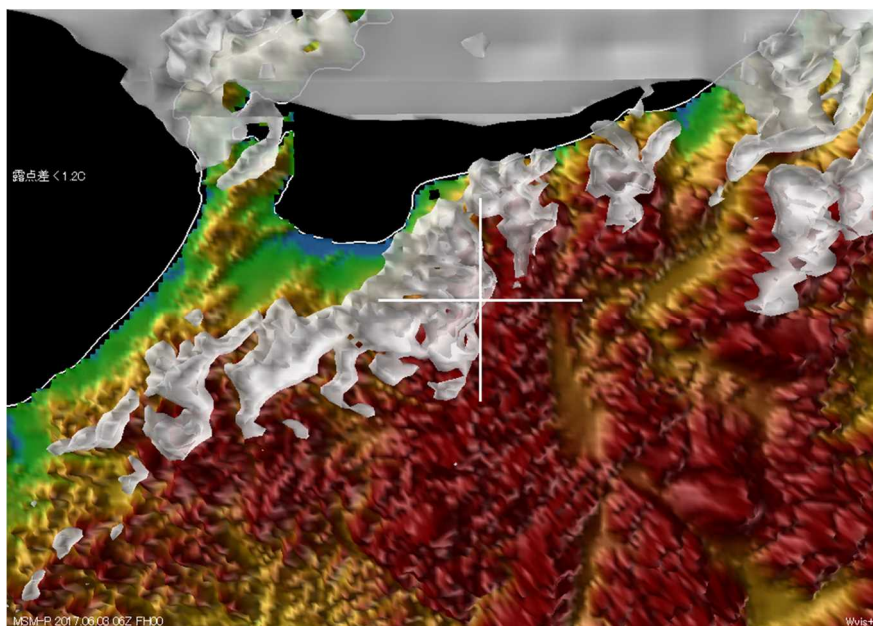

<③ Humid Air Area (White) Conditions>

Figure 2: Numerical Analysis Detail²⁶

2.7 Information on Accident Site and the Aircraft

2.7.1 Situation of Accident Site

2.7.1.1 Tateyama Mountain Range and Tateyama Caldera

The Aircraft was found at [Point y]²⁷ shown in Appended Figure 4 in the southeast slope of Mt. Shishi-dake in the Tateyama Mountain Range. As shown in Appended Figure 1 to 4, the accident site is surrounded by the Tateyama Caldera, the Ushiroateyama Mountain Range, and

²⁶ The Numerical Analysis Detail shows the analysis detail on the 700 hPa (altitude about 3,000 m: 10,000 ft) at 15:00 on June 3, 2017 immediately after the accident occurred.

²⁷ Each key position on the estimated flight route was marked alphabetically and described as “Position a” in Appended Figure 2 and Appended Figure 4 in this report.

Kurobe Canyon having the Kurobe Dam, and all around here is one of the greatest mountainous region of Chubu - Sangaku National Park in Japan. The mountain ridge of the accident site is a mountain trail and Murodo is also a base for mountain climbers in the Tateyama Mountain Range. The giant oval basin extending 6.5 km from east to west and about 4.5 km north to south, which is located in the south of Midagahara and Murododiara, forms steep slope of the Caldera²⁸ created by collapse and erosion of the Tateyama volcanic edifice where Mt. Ryuuou-dake and Mt. Shishi-dake are located in the east, and Mt. Washi-dake and Mt. Tonbisan in the south as its somma.

2.7.1.2 Situations of Traces of Collision and Sliding Down, and the Aircraft Wreckage

The prefectural police mountain ranger spotted the Aircraft early morning on June 4 on the day following the accident and seven days later, entered the accident site again on June 11. The ranger reported the following situation of the estimated accident site, the vicinity of Mt. Shishi-dake's top from where the Aircraft was assumed to have slid down in its south eastern slope.

On the south eastern snowy slope about 10 m downhill from the top of Mt. Shishi-dake where plenty of snow remained, there were two marks in parallel with the mountain ridge. (Point x: elevation about 2,700 m). Beside those marks, there were the nose landing gear with its struts equipped, and the left main landing gear beams. Further from that point on, two smartphones for Passenger A and Passenger B were found. Along those marks, there was the rock ridge around where many pieces of the Aircraft such as the left main wheel tire, pieces of the acrylic side windows, the broken control column in the left pilot's seat and others were scattered.

The marks that the Aircraft had slid down the slope were left along the snowy slope from the rock ridge in the vicinity of the mountaintop toward the valley. On this slope, there were also many pieces of the broken Aircraft, its flight manual and others were discovered. Further from that point onto the valley, there were the marks left by the Aircraft that had slid down the slope. A little above the point where the main body of the Aircraft was discovered on June 4 (Point y: elevation about 2,320 m), there was the engine with its propeller equipped. On June 11, the Aircraft was found to have further slid down the slope to the downstream point (Point z: elevation about 1,970 m).

(See Appended Figure 4: Estimated Flight Route (4,) Appended Figure 5: The Site of the Accident, Appended Figure 6: Estimated Crash Site, Marks and Traces, Appended Figure 7: The Site of Spotting the Aircraft, and Appended Figure 8: The Aircraft Found at the Accident Site)

2.7.2 Situation of the Aircraft

According to the prefectural police mountain ranger, the situation of then damages to the found Aircraft is as follows:

All the acrylic windows of the Aircraft were broken, the fixed bracket for the right front seat was broken and dislocated from the right position. The right side door was broken and left open and the fixed bracket for the aft seat was completely broken off. The protective net for the luggage area in the back of the seat was detached and got entangled with the ELT that was crashing onto the floor and sounding operating alarm with its switch ON. In addition, the auxiliary antenna for

²⁸ The past volcanic activities and earthquakes occurred in the west slope of the Tateyama Mountain Range and created the Tateyama Caldera that forms a steep slope.

the ELT was broken with a snap.



When the Aircraft was found, the ELT was lying on the floor under the aft seat with its operation panel switch ON. The auxiliary antenna for the ELT was broken with a snap.

Photo 8: The ELT of the Aircraft when it was found

2.7.3 Detailed Situation of Damage

On June 11, the Aircraft was found to have further slid down the slope to the downstream point (Point z) from the site (Point y) where the Aircraft was found on June 4. The altimeter setting was at 29.67 inHg, when found at Point y.

On July 6, the Aircraft and the engine were collected from the site and conveyed to Ryugasaki Office of the Company (Ibaraki Prefecture) for the Aircraft examination to confirm the following matters.

(1) Fuselage:

There were cracks in the cockpit right windshield and both windows of the aft seat, and the right door was left open.

The aft fuselage skin was found wrinkled.

(2) Main wings:

Left main wing tip was twisted backward in bowing upward.

The stall warning device functioned normally.

(3) Empennage:

The empennage right tip was bowed downward.

(4) Propeller:

Both of No. 1 and No.2 blades warped forward from the base and the No.2 blade tip was bowed backward.

The manufacturer of the propeller informed about the propeller's warping forward that their investigation results revealed the rotational energy absorption amount at the time of the crash of the Aircraft to be low.

(5) Landing gears:

The nose landing gear was destroyed and detached from the fuselage. The main landing gear bolts of the both sides were broken and the left gear was destroyed and detached while the right gear was heavily bowed. All the tires condition were found intact with the tire pressure remained.

(6) Engine:

All the engine access panels were broken and the engine was found detached with its propeller equipped.

(Fuel system) No traces such as stains, clogging, and leakage were found.

(Driving system) No faults were found when the engine was turned manually.

(Lubrication system) With sufficient lubricating oil supplied, stains and the inclusion of impurities were not confirmed.

(Ignition system) No faults were confirmed in the spark test and its ignition timing.

(Other engine parts) Impurities such as sand, water and lubricating oil were confirmed inside of the cylinder, but traces of faults were not found.

(7) Aircraft control system:

No traces of faults were confirmed in the ailerons and the elevators that were not seized.

(8) Electric system:

No abnormalities were found in the electric system including the related devices.

(9) Other systems:

No traces of faults were found in the Vacuum system (Attitude Indication), the Pitot-Static systems (Airspeed indicator, Altimeter and Vertical Speed Indicator)

(10) Situation of instruments in the cockpit, levers, switches and others:

- The Clock stopped at 14:50. The Airspeed Indicated 0 kt. The RPM indicated 0 rpm.
- The Vertical Speed Indicated +50 fpm. The Altimeter was normally functioning.
- The Attitude Indicator, the turn Sliding Indicator and the Directional Indicator did not function.
- The Course Deviation Indicator (CDI) was set at 160° (No. 1) and 240° (No. 2).
- The CDI displayed GS/NAV (No. 1) and NAV (No. 2).
- The Master switch was set to ON, the ignition was set to BOTH.
- The Pitot tube heater was set to ON, the carburetor heat to ON (Position PULL).
- The alternate static selector was set to OFF.
- The throttle lever and the mixture lever were almost set to the cruising position.
- The flap lever was bowed downward and crashed to the position of DOWN. (Actual flap positioned to UP)
- The VHF radio: The settings of the frequencies were not confirmed since it was broken both for communication and navigation.
- Automatic Direction Finder (ADF): It was set to NHK Matsumoto TV Station (540 kHz)
- Transponder Code: 0000 (The numeric set lever was set to Down position.)
- The cabin heat control was set to ON.

At Point "y"
June 4



Photo 9: Situation of Cockpit Instrument Panels

2.8 Medical Information

According to the autopsy results, the blood and urine samples of the PIC and the Pilot tested negative for alcohol and illegal drugs, the cause of the PIC's instant death was traumatic shock and the cause of Pilot's instant death was cerebral contusion. As for the cause of the death for the two passengers in the aft seat, both of them died of multiple traumas and the time of death was presumed at around 17:00 to 20:00.

2.9 Information on Communication

The air traffic control facilities and the Minister of Defense did neither have any records to have received an emergency communication on the frequency of 121.5 MHz, nor receive the code "7700" which notifies an emergency situation by transponder, and a distress signal transmitted from the ELTs that is to be described in the following 2.10.

2.10 Information on Search and Rescue (SAR) Operation

2.10.1 Situation in SAR Operations

The RCC received the information on the Aircraft from the Matsumoto Airport at 15:15. At 15:50, the RCC was informed that the Aircraft made a forced landing and judged it as the

DETRESFA²⁹ (distress phase). At 16:50, the RCC requested the Ministry of Defense to commence a disaster relief operation for lifesaving.

The Prefectural Police, upon receiving the first emergency call from Passenger A at 15:02, shared the information on the crash of the Aircraft with relevant departments. A Police Helicopter took off from Toyama Airport to search the Aircraft along with the Mountain Ranger. According to a pilot of the Police Helicopter, the situation in the SAR operations were as follows:

It was cloudy the whole sky. Therefore, the Police Helicopter could not cross the mountains to reach Kurobe Canyon. Instead, it flew toward the upstream of the Kurobe River via Kurobe City. Heading toward the Tateyama Mountain Range, the accident site, the Police Helicopter got to over Lake Kurobe. However, as the whole sky was covered with clouds with its ceiling at an around 2,100 m, they conducted the SAR operations only below this cloud ceiling. At about 17:00, the cloud ceiling was getting lower to about 1,900 m and more clouds were getting to be generated from the valley. Kurobe Canyon was also getting covered with low-hanging clouds. Judging that it would be difficult to conduct the SAR operation at the site any more, the Police Helicopter terminated the SAR operation and returned to Toyama Airport. According to the Prefectural Police, the Police Helicopter is equipped with a radio reception device having two-way communication systems. It was reported that the Police Helicopter listened on the frequency for the Prefectural Police Headquarters and the aircraft intercommunication other than the frequency for ATC communications, but it did not listen on the aeronautical distress frequency 121.5 MHz during its SAR operation.

On the other hand, according to the Ministry of Defense, a SAR Helicopter and a SAR Airplane took off from the airport at 18:00 and at 18:04, respectively, and headed to the accident site. The SAR Helicopter flew under the clouds, got to over the Kurobe Dam and launched the SAR operation. The SAR Airplane flew on-top flight at an altitude of 12,500 ft and made the SAR operation through rifts of clouds. During the SAR operation, in spite of monitoring the distress frequencies 121.5 MHz and 243 MHz, the SAR Aircrafts of the Defense Ministry did not receive any emergency signals on those frequencies during SAR operation on June 3.

At 04:38 on June 4, on the following day of the accident, the Police Helicopter took off from Toyama Airport to search the Aircraft and found it on the southeast slope of Mt. Shishi-dake at 05:01.

At 06:02 and 06:08 on June 4, a SAR aircraft of the Defense Ministry received a distress signal seemed from the Aircraft.

2.10.2 Convention on International Civil Aviation (ICAO) Rules

Annex 12 to the Convention on International Civil Aviation contains the following descriptions (the Standards³⁰ and Recommended Practices³¹) about the search and rescue equipment for SAR organizations at the time of occurrence of the aircraft accident. (Excerpts)

²⁹ The DETRESFA (distress phase) is the final phase to issue the initiation of the search and rescue (SAR) operation.

³⁰ "Standard": Any specification for physical characteristics, configuration, materiel, performance, personnel or procedure, the uniform application of which is recognized as necessary for the safety or regularity of international air navigation and to which Contracting States will conform in accordance with the Convention.

³¹ "Recommended Practice": Any specification for physical characteristics, configuration, materiel, performance, personnel or procedure, the uniform application of which is recognized as desirable in the interests of safety, regularity or efficiency of international air navigation, and to which Contracting States will endeavor to conform in accordance with the Convention.

2.6 Search and rescue equipment

2.6.1 Search and rescue units shall be provided with equipment for locating promptly, and for providing adequate assistance at the scene of an accident.

2.6.2 (Recommendation) – Each search and rescue unit should have means of rapid and reliable two-way communication with other search and rescue facilities engaged in the same operation.

2.6.3 Each search and rescue aircraft shall be equipped to be able to communicate on the aeronautical distress and on scene frequencies and on such other frequencies as may be prescribed.

2.6.4 Each search and rescue aircraft shall be equipped with a device for homing on distress frequencies.

2.10.3 Information on Seats and Seatbelts

According to the prefectural police mountain ranger, the situation of occupants, when the Aircraft was found, was as follows:

The PIC in the right front seat fastened the waist seat belt but not the shoulder harness. His upper body was protruded from the broken door. The Pilot in the left front seat also fastened the waist seat belt but not the shoulder harness. Passenger A in the right aft seat and Passenger B in the left aft seat did not fasten three point type seatbelt combining waist seatbelt with shoulder harness.

2.11 Records on the ARSR

ARSR, which is used for the air route traffic control service by radar such as detecting the aircraft position, guiding aircraft and setting separations between aircrafts, covers airspace within a 200 nm radius. In the aircraft accident investigation, it was estimated to be the flight track record of the Aircraft by analyzing the transponder code: 1200, which was transmitted from the VFR aircraft that did not have its specific code and acquired on the radar installed in Noto town (Ishikawa Prefecture), and by judging from the takeoff time, the flight route, and the position where the response signal stopped.

As described in 2.7.3, the altimeter setting (QNH) of the Aircraft was set at 29.67 inHg at the time of the accident occurrence. However, the ASAR recorded the setting correction to 29.92 inHg, which caused about 250 ft difference between the read out altitude on the Aircraft's altimeter and the recorded altitude on the ARSR. In addition, as the altitude is recorded every 100 ft on the ARSR, its recorded altitude includes ± 50 ft difference.

2.12 Rules of the Civil Aeronautics Act

2.12.1 Visual Meteorological Conditions

Regarding the visual meteorological conditions, the followings are stipulated in Article 5 of the Ordinance for Enforcement of Civil Aeronautics Act of Japan (excerpts): The Figure 3 to 5 were created by the Japan Transport Safety Board (JTSB).

(ii) *Aircraft that flies at an altitude less than 3,000 meters (excluding aircrafts listed in the following item): Each listed weather condition according to the classification of aircrafts listed in the following items:*

- (a) *Aircraft that flies in air traffic control area ³²(hereinafter referred to as "control area"), air*
- Flight visibility is over 5,000 meters*
 - No cloud is within the vertical distance of 150 meters above and 300 meters below the aircraft*
 - No cloud is within the horizontal distance of 600 meters from the aircraft.*

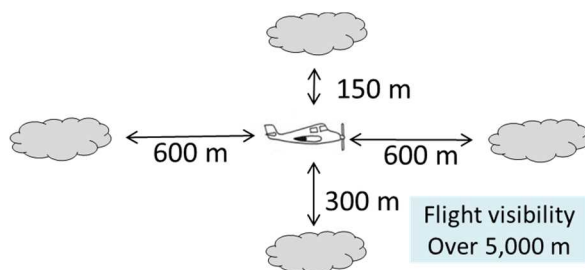

(Aircraft that flies in control area, control zone and information zone at an altitude of less than 3,000 meters)

Figure 3: Visual Meteorological Condition (1)

(b) *Aircraft flies in the airspace other than control area, control zone and information zone: Weather conditions that meet requirements:*

- Flight visibility is over 1,500 meters.*
- No cloud is within the vertical distance of 150 meters above and 300 meters below the aircraft.*
- No cloud is within the horizontal distance of 600 meters from the aircraft.*

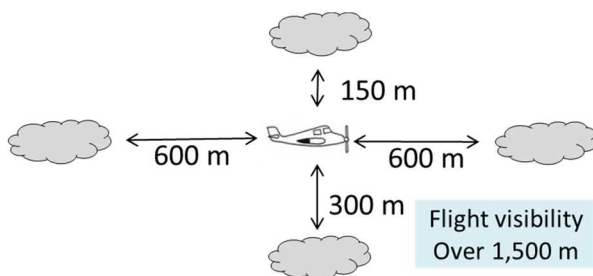

(Aircraft that flies in the airspace other than the control area, the control zone and the information zone at an altitude of less than 3,000 meters)

Figure 4: Visual Meteorological Condition (2)

³² Out of the airspace where the Aircraft flew, the airspace which is over 600 m (2,000 ft) above the ground surface was in control area, control zone or information zone, to which Paragraph ii (a) of Article 5 of the Ordinance for Enforcement of Civil Aeronautics Act of Japan shall be applied; If the traffic control zone (hereinafter referred to as "control zone") or air traffic information zone (hereinafter referred to as "information zone"): Weather conditions that meet requirements; Aircraft flies over the mountains in the airspace at an altitude less than 600 m (2,000 ft) above the ground surface, Paragraph ii (b) shall be applied since it is the outside of the control area; in addition, if the Aircraft flies at an altitude less than 300 m above the ground surface, Paragraph iii shall be applied.

- (iii) *Aircraft that flies at an altitude less than 300 meters from the ground surface or the water surface in the airspace other than the control area, the control zone and the information zone Weather conditions that meet requirements:*
 - (a) *Flight visibility is over 1,500 meters.*
 - (b) *Aircraft may fly away from clouds and that the pilot may visibly recognize the ground surface or the water surface.*

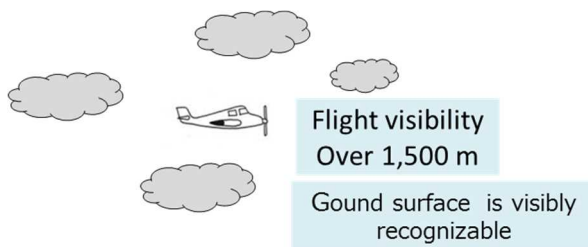

(Aircraft that flies at an altitude less than 300 meters from the ground surface in the airspace other than the control area, the control zone and the information zone)

Figure 5: Visual Meteorological Condition (3)

2.12.2 Minimum Safety Altitude

Regarding the minimum safety altitude for aircraft navigating on a visual flight rules, the following are stipulated in Article 174 of the Ordinance for Enforcement of Civil Aeronautics Act of Japan (excerpts):

- (i) *In the case of aircraft navigating on a visual flight rules shall take any of the highest of the altitude at which landing is feasible, when power system only has stopped during a flight, without causing danger of human beings or objects on the ground or on water and the following altitudes:*
 - (a) *In the case of a space over a densely populated area with human beings or houses, an altitude higher by 300 meters than the top edge of the highest object located within an area with a horizontal distance of 600 meters with the aircraft at its center.*
 - (b) *In the case of above an area without human beings or houses, an altitude at which an aircraft can continue flight while maintaining a distance of 150 meters or more from human beings or objects on the ground or on water.*
 - (c) *In the case of a space over an area other than that prescribed under (a) and (b), an altitude of 150 meters from the ground or water surface.*

2.13 Rules of the Company

2.13.1 Decision on Turning Back, Emergency Communication and Others

The rules of the Company stipulates as follows:

In case of aircraft of aerial work services on a visual flight rules, the aircraft shall avoid flying over the mountain regions and over the sea as much as possible. In case that it becomes to be difficult to maintain the visual meteorological conditions (VMC)³³ despite of changing altitude or route, the aircraft shall appropriately change the flight plan such as turning back and changing the landing site by taking into consideration the remaining amount of fuel. In addition, in case of an emergency situation or a distress, the PIC shall make an emergency communication or send a

³³ “VMC” stands for Visual Meteorological Conditions.

distress signal.

2.13.2 Performance of the Same Type of Aircraft

In the Pilot's Operating Handbook (hereinafter referred to as "POH") of the same type of aircraft contains the following descriptions.

(1) Climb Performance

Service ceiling: 13,000 ft

Table 2: Maximum Rate of Climb

Weight (LBS)	Press ALT (FT)	Climb Speed (KIAS)	Rate of Climb (fpm)			
			-20°C	0°C	10°C	20°C
2,400	<i>S.L</i>	76	805	745	685	625
	2,000	75	695	640	580	525
	4,000	74	590	535	480	420
	6,000	73	485	430	375	320
	8,000	72	380	330	275	220
	10,000	71	275	225	175	...
12,000	70	175	125	

(Condition) Flaps: Up, Throttle: Full Open

(Note) On a flight at an altitude of 3,000 ft or more, lean the mixture for maximum RPM.

According to the manufacture of the same type of aircraft, it is possible to fly at an altitude of 12,000 ft or more depending on weather conditions or weight.

(2) Stall Speeds

Table 3: Stall Speeds

Weight (LBS)	Flap Deflection	Angle of Bank			
		0°	30°	45°	60°
KIAS					
2,400	<i>UP</i>	44	47	52	62
	10°	35	38	42	49
	30°	33	35	39	47

(Condition) Power: Off

(Note) The flight altitude loss during the recovery from stall is 230 ft.

2.13.3 Ban on Flight in Icing Conditions

According to the limitations in the flight manual of the Aircraft, the flight is prohibited under the weather conditions where icing conditions are predicted. In addition, its emergency procedures stipulate the following check list, stating that it is the best way to turn back or change altitude in order to exit the icing conditions when encountering an inadvertent icing. (Excerpts)

Inadvertent Icing Encounter

1. Turn pitot heat switch ON.
2. Turn back or change altitude to obtain an outside air temperature that is less conducive to icing.
3. Pull cabin heat control full out and open defroster outlet to obtain maximum windshield defroster airflow. Adjust cabin air control to get maximum defroster heat and airflow.

4. *Open the throttle to increase engine speed and minimize ice build-up on propeller blades.*
 5. *Watch for signs of carburetor air filter ice and apply carburetor heat as required. An unexplained loss in engine speed could be caused by carburetor ice or air intake filter ice. Lean the mixture for maximum RPM, if carburetor heat is used continuously.*
 6. *Plan a landing at the nearest airport. With an extremely rapid ice build-up, select a suitable “off airport” landing site.*
 7. *With an ice accumulation of 1/4 inch or more on the wing leading edges, be prepared for significantly higher stall speed.*
 8. *Leave wing flaps retracted. (omitted)*
 9. *Open left window and, if practical, scrape ice from a portion of the windshield for visibility in the landing approach.*
- (omitted)*

2.14 Flight Record of the PIC and the Pilot

2.14.1 Flight Record of the PIC

The flight record³⁴ for one month up to the accident is as follows:

Table 4: Flight Record of the PIC (for One Month up to the Accident)

Date	Flight Times	Total Flight Time	Type of Flight	Flight Route (excerpts)
May 3, 2017	4	2:10	Sightseeing flights	Matsumoto Airport – Islands – Kamikochi – Mt. Hotakatake– Mt. Yarigatake – Matsumoto Airport Matsumoto Airport – Islands – Kamikochi – Mt. Hotakatake– Mt. Yarigatake – Matsumoto Airport
May 4, 2017	2	0:30	Sightseeing flights	Matsumoto Airport – Suwa – Matsumoto Airport
May 5, 2017	4	0:50	Sightseeing flights	Matsumoto Airport – Matsumoto – Matsumoto Airport Matsumoto Airport – Azumino – Matsumoto Airport
May 6, 2017	1	0:10	Sightseeing flights	Matsumoto Airport – Matsumoto – Matsumoto Airport
May 7, 2017	3	1:43	Flight training Sightseeing flights	Matsumoto Airport – Matsumoto – Matsumoto Airport Matsumoto Airport – Islands – Mt. Hotakatake–Mt. Yarigatake – Matsumoto Airport
May 8, 2017	2	6:23	Photo mission	Matsumoto Airport – Islands – Kamikochi - Mt. Hotakatake – Mt. Yarigatake– Matsumoto Airport Matsumoto Airport – Nagano – Shinanomachi – Myoko– Joetsu - Matsumoto Airport
May 12, 2017	1	0:30	Photo mission	Matsumoto Airport – Suwa – Utsukushigahara – Matsumoto Airport
May 17, 2017	3	4:06	Photo mission Contracted flight mission	Matsumoto Airport – Nagano – Chikuma – Matsumoto– Matsumoto Airport Matsumoto Airport – Shonai Airport – Matsumoto Airport
May 19, 2017	2	1:45	Contracted flight mission	Matsumoto Airport – Shonai Airport – Matsumoto Airport

³⁴ For example, “28:22” in the table means the total flight time is 28 hours 22 minutes.

May 20, 2017	2	0:50	Sightseeing flights	Matsumoto Airport – Islands – Kamikochi – Mt. Hotakatake– Matsumoto – Matsumoto Airport
May 21, 2017	1	1:10	Sightseeing flights	Matsumoto Airport – Suwa – Chino – Matsumoto Airport
May 24, 2017	2	2:05	Sightseeing flights Photo mission	Matsumoto Airport – Kamikochi – Mt. Hotakatake – Kurobe Dam – Matsumoto Airport Matsumoto Airport – Ueda – Komoro – Matsumoto Airport
May 26, 2017	2	0:40	Sightseeing flights	Matsumoto Airport – Azumino – Matsumoto Airport Matsumoto Airport – Azumino – Matsumoto Airport
May 26, 2017	3	3:02	Contracted flight mission	Matsumoto Airport – Shonai Airport – Matsumoto Airport – Yao Airport
May 28, 2017	2	2:05	Sightseeing flights Photo mission	Matsumoto Airport – Nagano – Iidzunachou – Suzaka – Matsumoto Airport Matsumoto Airport – Suwa - Azumino – Matsumoto Airport
May 29, 2017	1	0:56	Photo mission	Matsumoto Airport – Nagano – Ueda – Matsumoto Airport
May 31, 2017	1	1:08	Photo mission	Matsumoto Airport – Suzaka – Matsumoto – Matsumoto Airport
June 3, 2017	1	1:34	Flight training (Instructor)	Matsumoto Airport – Omachi – Itoigawa – Uozu - Toyama Airport

2.14.2 Flight Record of the Pilot

In August 2007, the Pilot commenced to take pilot training lessons, most of which the PIC gave to the Pilot as his instructor. The Pilot earned a private pilot certificate in January 2012 and regularly made a one-hour flight once a month since April 2016.

According to the flight experience of the Pilot, in April 2012, October 2014 and June 2015, although their flight routes are unknown, he flew for Toyama Airport, and the flight on the day of the accident was his fourth for Toyama Airport. Besides, his total flight time as the PIC was 92 hours 39 minutes.

Table 5: Flight Record of Pilot (Excerpts from October 2014 onward)

Date	Flight Route (excerpts)	Total Number of Occupants	PIC Name in Flight Plan
October 26, 2014	Matsumoto Airport – Toyama Airport / Toyama Airport – Matsumoto Airport (Flight route unknown)	Unknown	Unknown
June 7, 2015	Matsumoto Airport – Toyama Airport / Toyama Airport – Matsumoto Airport (Flight route unknown)	Unknown	Unknown
April 3, 2016	Matsumoto Airport – Suwa – Chino – Matsumoto Airport	3	Pilot
April 23, 2016	Matsumoto Airport – Utsukushigahara – Chino – Suwa – Matsumoto Airport	2	Pilot
May 5, 2016	Matsumoto Airport – Suwa – Chino – Matsumoto Airport	2	Pilot
May 22, 2016	Matsumoto Airport – Utsukushigahara – Lake Shirakaba – Chino – Suwa – Matsumoto Airport	4	Pilot
June 4, 2016	Matsumoto Airport – Islands – Kamikochi – Mt. Hotakatake – Mt. Yarigatake – Kurobe Dam – Matsumoto Airport	2	Pilot
June 18, 2016	Matsumoto Airport – Islands – Mt. Norikuradake – Otakimura –	1	Pilot

	Kisofukushima – Matsumoto Airport		
July 10, 2016	Matsumoto Airport – Toriitoge – Otakimura– Kisofukushima – Matsumoto Airport	3	Pilot
July 31, 2016	Matsumoto Airport – Islands – Mt. Hotakatake – Mt. Yarigatake – Kurobe Dam - Omachi – Matsumoto Airport	3	Pilot
August 20, 2016	Matsumoto Airport – Omachi – Matsumoto Airport	1	Pilot
September 4, 2016	Matsumoto Airport – Suwa – Matsumoto Airport	1	Pilot
September 25, 2016	Outward: Matsumoto Airport – Kofu – Otsuki – Odawara – Oshima Airport Homeward: Oshima Airport – Ito – Fujinomiya – Nirasaki – Matsumoto Airport	4	PIC
October 2, 2016	Matsumoto Airport – Suwa – Chino – Matsumoto Airport	2	Pilot
October 23, 2016	Matsumoto Airport – Suwa – Chino – Matsumoto Airport	2	Pilot
November 13, 2016	Matsumoto Airport – Islands – Mt. Hotakatake – Mt. Yarigatake –Kurobe Dam -Omachi – Matsumoto Airport	2	Pilot
December 4, 2016	Matsumoto Airport – Islands – Mt. Hotakatake – Mt. Yarigatake – Kurobe Dam -Omachi – Matsumoto Airport	1	Pilot
January 9, 2017	Matsumoto Airport – Suwa – Chino – Matsumoto Airport	1	Pilot
February 12, 2017	Matsumoto Airport – Utsukushigahara – Chino – Suwa – Matsumoto Airport	2	Pilot
March 5, 2017	Matsumoto Airport – Islands – Kamikochi – Mt. Hotakatake – Mt. Yarigatake – Kurobe Dam – Matsumoto Airport	2	Pilot
April 2, 2017	Matsumoto Airport – Suwa – Okaya - Toyama Airport	2	Pilot
April 23, 2017	Matsumoto Airport – Islands – Mt. Hotakatake – Mt. Yarigatake – Kurobe Dam – Matsumoto Airport	3	Pilot
May 14, 2017	Matsumoto Airport – Omachi – Azumino – Matsumoto Airport	1	Pilot
June 3, 2017	Matsumoto Airport – Omachi – Itoigawa - Uozu – Toyama Airport	4	PIC

2.15 Icing

2.15.1 Icing Conditions

As for the icing conditions and the detection of icing, “FAA-AC_91-74B (Flight in Icing Condition)” published on October 25, 2015 states as follows (excerpts):

Aircraft icing remains a key aviation safety issue. Accident data has shown that pilots are (intentionally or inadvertently) flying aircraft not certificated for flight in icing conditions into such conditions, often with fatal results. (omitted)

If an aircraft is not certificated for flight in icing conditions, each flight should be planned carefully so that icing conditions are avoided. During a flight, the pilots should monitor available weather information and be aware of conditions that might require a change of flight plan to avoid icing conditions. In the event of an inadvertent icing encounter, the pilot should take appropriate action to exit the conditions immediately. (omitted)

Nearly all aircraft icing occurs in supercooled clouds. (omitted) At OAT close to 0 °C (32° F), the cloud may consist entirely of such drops, with few or no ice particles present. (omitted)

Ice accumulation is often greatest at temperatures not too far below 0 °C (32 °F), where LWC can be abundant.

2.15.2 Effects of Icing

As for the effects of icing, “FAAAC Flight in Icing Condition” states as follows (excerpts):

A thin ice accretion on critical surfaces that develops in a matter of minutes can have dramatic effects on stall speeds stability, and control. (omitted)

Note that the Maximum Coefficient of Lift (CL_{max}) is significantly reduced by the ice, and the Angle of Attack (AOA) at which a stall occurs (the stall angle) is much lower with ice than without ice. (omitted) A significant reduction in CL_{max} and a reduction in the AOA where stall occurs can result from a relatively small ice accretion. (omitted) A reduction of CL_{max} by 30 percent is not unusual. (omitted) Drag tends to increase steadily as ice accretes. An airfoil drag increase of 100 percent is not unusual.

Ice forms on aircraft structures and surfaces when supercooled droplets adhere to them and freeze. Small and/or narrow objects are the best collectors of drops and ice up most rapidly. This is why a small protuberance within sight of the pilot can be used as an ice evidence probe.

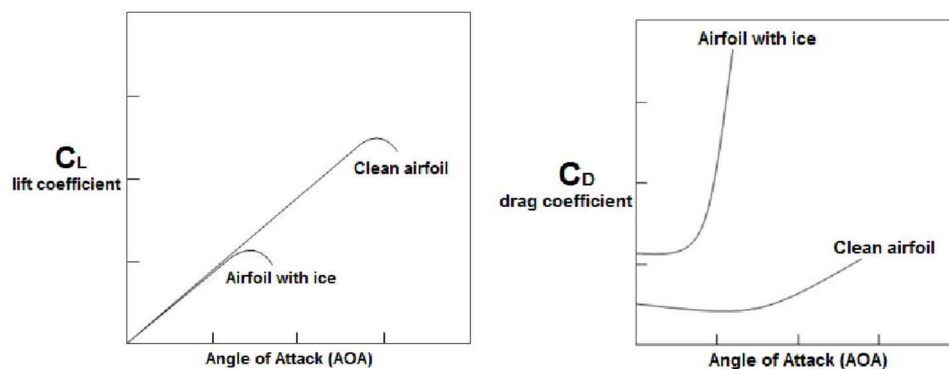

2.15.3 Icing in Mountain Regions

As for the icing in mountain regions, “FAA-AC_00-06B (Aviation Weather)” published on August 26, 2016 states as follows (excerpts):

Icing is more likely and more severe in mountainous regions. Mountain ranges cause upward air motions on their windward side. These vertical currents support large supercooled water droplets above the freezing level. (omitted)

The most severe icing occurs above the crests and on the ridges' windward side. This zone usually extends to about 5,000 feet above the mountaintops, but can extend much higher if cumuliform clouds develop.

Icing with mountains can be especially hazardous because a pilot may be unable to descend to above freezing temperatures due to terrain elevation. If a pilot approaches a mountain ridge from the windward side, his aircraft may be unable to climb above the mountaintops, or even maintain altitude due to severe ice accumulation. The end result may be a crash.

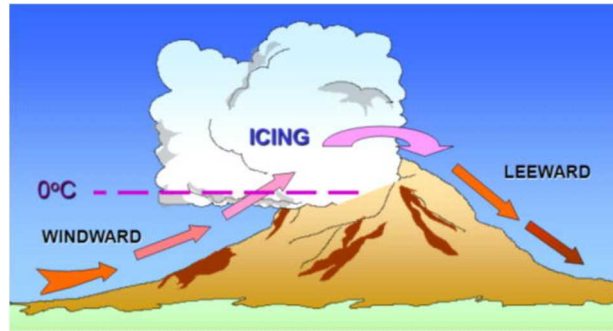

Figure 7: Icing in Mountain Regions

2.16 Mountain Flying

2.16.1 Preparations and Precautions for Mountain Flying

“FAA-P-8740-60 AFS-803 (1999) _00-06B (Tips on Mountain Flying) published by the FAA states as follows (excerpts):

2.16.1.1 Requirements for Pilot

Because of the more demanding nature of mountain flying, you should carefully consider your experience and background before beginning a flight into mountainous terrain. (omitted) First, it is essential that you consider attending a recognized mountain flying course to give you the knowledge and skills you will need to be safe. Second, it is usually a good idea to wait until you have at least 150 hours of pilot in command time logged before taking mountain training. Pilots with this amount of time have usually had time to become more familiar and comfortable with the airplane and with planning flying trips.

2.16.1.2 Requirements for Aircraft

Mountain flying presents demands on both the pilot and the airplane that may require more performance than light training aircraft have to offer. (omitted) .160 horsepower should be considered minimum for the airplane³⁵ with a pilot with minimum mountain experience. Even that, however, will greatly limit your ability to react to strong winds and the up and down drafts they may cause. The aircraft gross weight and its affect on performance should be carefully considered. A minimum of 60 horsepower per occupant should be considered minimum.

2.16.1.3 Requirements for Meteorological Conditions

It is suggested that you cross mountain passes at an altitude at least 1,000 feet above the pass elevation. (omitted) You should make sure that you have at least a 2,000 foot ceiling over the highest pass you will cross. (omitted)

Many experienced mountain pilots recommend having at least 15 miles of visibility before attempting mountain flights. (omitted)

Strong winds can cause some of the most dangerous conditions you'll have to contend with in the mountains. To minimize the chance of encountering dangerous turbulence, mountain flying should not be attempted if the winds aloft forecast at mountain top levels are greater than 25 knots. Above this level, potentially dangerous turbulence, as well as very strong up and down drafts are likely.

³⁵ Cessna 172P is a 160-horsepower aircraft.

2.16.1.4 Crossing of Mountain Ridges and Passes

On most mountain flights, you will need to cross at least one ridge or pass. Experienced pilots recommend crossing a ridge or pass at the ridge elevation plus at least 1,000 feet. If the winds at mountain top level are above 20 knots, increase that to 2,000 feet. Plan to be at that altitude at least three miles before reaching the ridge and stay at that altitude until at least three miles past it. This clearance zone will give you a reasonable safety zone to avoid the most severe turbulence and down drafts in windy conditions.

2.16.1.5 Options to be Taken When Weather Deteriorates Enroute

A particularly difficult situation for most pilots to deal with is weather that deteriorates enroute. The urge to continue is very strong, with the thought that it will get better if we just continue a little farther. However, continuing is often the worst thing you can do. When the weather begins to deteriorate, begin to consider what your options are. Your flight planning should have included planning for alternate routes or airports and those should be exercised before getting into poor weather. Divert to an alternate airport or return to your departure airport and reconsider the weather conditions.

If the weather closes off all other possible options, the best thing to do might be to make an off airport landing. Making a landing under control while you still have enough visibility to select a good site is preferable to continuing into poor weather and crashing into terrain that you can't see.

2.16.2 Turbulence in the Vicinity of the Mountaintop

(1)As for the turbulence in the vicinity of the mountaintop, “FAA-AC_00-06B (Aviation Weather)” states as follows (excerpts):

Mountain waves often produce violent downdrafts on the immediate leeward side of the mountain barrier. Sometimes the downward speed exceeds the maximum climb rate of an aircraft and may drive the aircraft into the mountainside.

(2) As for mountain waves, the literature³⁶ states as follows:

Mountain waves tend to be generated on the leeward side of the mountains. The stronger the wind in the vicinity of the mountaintop and the greater the altitude gap between the mountains and the surroundings, the wider the amplitude of mountain waves becomes. In addition, mountain waves is more likely to occur when the winds in the vicinity of the mountains blows and hits at the mountains almost at a right angle.

The aircraft on a mountain flight at low altitude will need to assume the encounter of stronger turbulence and downdrafts if the winds aloft at mountain top levels are greater than 20 knots. Besides, it is desirable that the aircraft on mountain flights should cross the mountaintop at the mountaintop elevation plus at 5,000 ft or more in order to avoid mountain waves, but 2,000 ft is necessary at least.

³⁶ Those regarding “mountain waves” were excerpted from “Aviation Weather Lecture Note” (Written by Toshitsuna Ichiki, Hobun-books).

2.17 ELT (Emergency Locator Transmitter)

2.17.1 Regulations on ELT

The obligations to equip an aircraft with first-aid tools are stipulated in Article 62 of the Civil Aeronautics Act of Japan. And the Article 150 of the Ordinance for Enforcement of Civil Aeronautics Act of Japan stipulates the types of aircraft required to equip with those emergency equipment, emergency equipment items and the required numbers of those equipment. In compliance with the amendment of Annex 10 (2008) to the Convention on International Civil Aviation, the requirements for emergency equipment including an ELT were also revised. And accordingly, the relevant equipment requirements regarding first-aid tools in the Article 150 of the Ordinance for Enforcement of Civil Aeronautics Act of Japan were also revised to help locating the aircraft in distress as soon as possible at the time of the SAR operation. Pursuant to this revision, it was required to equip an aircraft with one unit of ELT or two units of ELTs depending on the aircraft classification. In the revised Article 150, it is stipulated that “Aircraft (limited to aircraft which airworthiness certificate and others. is first issued after 1 July 2008) shall be equipped with one emergency locator transmitter activated automatically by impact (hereinafter referred to as “Automatic ELT”) However, the Aircraft, which airworthiness certificate was first issued in November 1986, was certified to equip with other type of ELT (not Automatic ELT) and required to equip with one unit of ELT.

In addition, according to Annex 6 to the Convention on International Civil Aviation, an ELT may take any of the following forms: Automatic Fixed ELT (AF), Automatic Portable ELT (AP), Automatic Deployable ELT (AD) and Survival ELT (S). The Aircraft was equipped with one unit of the Automatic Portable ELT (KANNAD406).

2.17.2 The ELT on the Aircraft

2.17.2.1 Descriptions in Manufacturer’s Manual

The ELT manufacturer’s manual has the following descriptions of the ELT on the Aircraft:

The Automatic Portable ELT (AP) shall be equipped in an aircraft. Continuously operating on both 121.5 MHz and 243 MHz and sending signals for SAR activities from the outside antenna installed on the fuselage, the ELT (AP) shall transmit a 406 MHz distress signal³⁷ to the SAR satellite every 50 seconds in order to help precisely locating and identifying the aircraft in distress. An auxiliary antenna shall be used when the ELT (AP) is used as a Survival ELT (S).

A bracket is mounted on the fuselage tail section and ELTs are secured to the mounting bracket with a hook loop fastener³⁸. The 3-position toggle switch ARM/OFF/ON are found on an ELT operation panel. By setting to ARM on a normal flight, the ELT can be activated either automatically by G-Switch³⁹ sensor if the aircraft gets a jolt. In addition, with the switch of the ELT in position ARM, it is possible for a pilot to transmit a distress signal by means of the remote panel in the cockpit. Upon selecting ON, the ELT will start issuing a distress signal. As this toggle switch is designed to be controlled by pulling the switch lever toward in order to prevent a malfunction / wrong transmission, it cannot be switched ON by the shock of the accident.

³⁷ It is designed in such a way that when an aircraft in distress transmits an emergency signal on 406 MHz, the SAR satellite (COSPAS-SARSAT) receives the signal, and after the signal is relayed to a ground-based station, the information is delivered to search and rescue facilities.

³⁸ The hook loop fastener can be attached and removed by the fastener.

³⁹ “G-Switch” is designed to detect the shock acceleration of specified direction (travel direction of the aircraft in case of a fixed wing aircraft), however, there are some cases where a G-Switch cannot detect any shock depending on the direction in which the impact is applied.

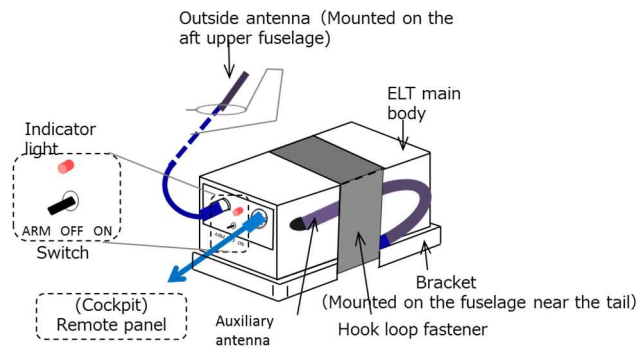

Figure 8: Standard Installation of Automatic Portable Type of ELT

How to use an Automatic Portable ELT (AP) as a Survival ELT (S) is described as follows:

1. Switch OFF the ELT.
2. Remove the outside antenna and the remote control panel.
3. Remove the hook loop fastener.
4. Remove the ELT main body and the auxiliary antenna from the bracket.
5. Connect the auxiliary antenna.
6. Switch ON the ELT.

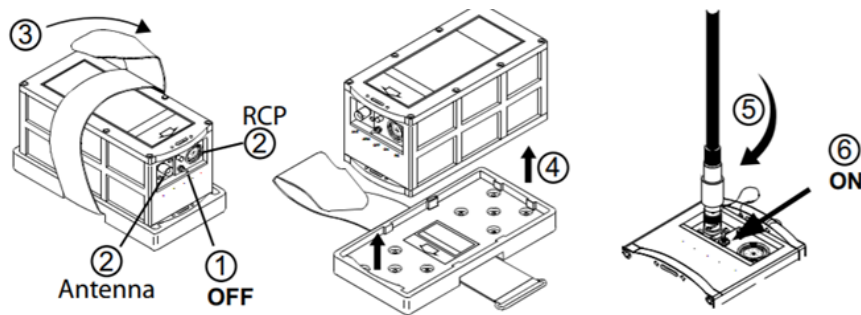

Figure 9: How to Use an Automatic Portable ELT as a Survival ELT

2.17.2.2 Operation and Management Status of the ELT in the Company

In the Company, the ELT bracket for the Aircraft was not secured to the fuselage and the ELT, which was connected to the auxiliary antenna, was fastened with the bracket as a unit by the hook loop fastener. And those sets of ELTs were stored on the office rack. The Company's pilot used to bring one of them before the flight and bring it back after the flight. The Company made it a rule that after the self-test⁴⁰ of the ELT, the Company's pilot was supposed to stow the ELT unit in the rear luggage storage area of the aircraft and cover it with the protection net. As shown in Photo 10, the rear luggage storage area of the same type of aircraft is a carpeted floor. The ELT was found put on the floor and not secured to the fuselage of the aircraft.

Besides, in the same type of aircraft, the Company did not stow the leaflet, which describes how to use the ELT for emergencies.

⁴⁰ The "self-test" is an operation test to check ELT functions.



Photo 10 : Installation / Mounting State of an ELT
in the same Type of Aircraft

2.17.2.3 Function Test on ELT

Regarding the function test (state investigation) of the ELT installed on the Aircraft, we commissioned an analysis institution and the report is as follows (excerpts):

The battery voltage was 9.30 V that was enough to normally function even in a low circumstance. The ELT's transmission power, frequency and modulation degree for any of those 121.5 MHz, 243 MHz and 406 MHz were all in compliance with the regulations. Therefore, if a distress signal was received, it could have identified the ELT signal transmitted from the Aircraft and the mounted G-switch would have functioned normally.

The ELT auxiliary antenna was broken at the base and almost disconnected. Under those conditions, it is probable that it would be limited to within several hundred meters to be able to receive the radio waves on 121.5 MHz and 243 MHz, and as for on 406 MHz, it would be several kilometers.

It is also probable that as an electromagnetic shield was provided inside of the ELT body (KANNAD 406), when radiating from the ELT body (the antenna not connected), a distress signal could be sent from its cover panel side, and radio waves could become directional. In addition, the electric field intensity of VHF and UHF waves transmitted from the ELT would become significantly lower behind obstacles. It is somewhat likely that as the way of installing the ELT in the Aircraft limited the radio waves transmission from the ELT to the direction in which the ELT was visible from the Aircraft's windows, the radio coverage, which the SAR aircraft could listen on the distress signal, was also limited, and the possible radio detection coverage areas might have become less accessible if the ELT cover panel did not face to the fuselage window at the time of radiation.

The number of transmissions on 406 MHz, which was recorded on the Aircraft's ELT, was 1,310 times.

2.17.2.4 Safety Alert on the ELT (NTSB)

In December 2015, the National Transportation Safety Board (NTSB) issued the following safety alert on ELTs for pilots and land owners in addition to introducing past case examples in which the ELTs were found inoperable when the accident of small airplanes occurred. (The following descriptions are excerpts.)

Related accidents

Several NTSB accident investigations have found ELT switches in the "off" position (thus, not "armed") and ELTs detached from the airplane, which rendered them inoperable. In these cases, the inoperability of the ELTs delayed the aircraft's discovery and/or the rescue of occupants. The NTSB is concerned that these examples of ELT issues represent a more widespread problem that could endanger the lives of pilots and passengers who survive an aircraft accident in a remote area.

(omitted)

What can pilots, aircraft owners, and maintenance technicians do?

- *Confirm that the ELT unit is "armed" and properly installed in the aircraft.*
- *Follow manufacturer instructions for properly securing the ELT and inspecting the fasteners.*
- *Remember that ELTs secured to the aircraft via Velcro-style mounting mechanisms can be susceptible to strap looseness and misalignment during installation and inspection. Further, the retention straps may degrade overtime due to wear, vibration, temperature, or contamination, and they may not properly restrain the ELT during an accident.*

2.18 Similar Accidents and Incidents

2.18.1 Similar Accidents and Incidents in the Past

Among the similar accidents and incidents in VFR flying that had occurred for ten years since November 2007, those considered relating to unsustainable visible meteorological conditions or turbulence are as follows:

Table 6: Similar Accidents in the Past

<i>Date of Occurrence</i>	<i>Site of Occurrence</i>	<i>Type of Aircraft</i>	<i>Outline of Accident</i>	<i>Probable Cause</i>	<i>Time until the Aircraft's Discovery</i>	<i>ELT Condition</i>
November 15, 2007	Nakatsugawa City, Gifu Pref.	Cessna 404P (JA5257)	Crash into the grove on the mountaintop	Flying toward a mountain covered with clouds, it could not avoid the mountain.	About 2 hours	**
July 6, 2008	Shimokita Dist. Aomori Pref.	Aerospatiale AS350B (JA9755)	Crash into the sea	Flying at an altitude close to the sea surface in a fog, it could not maintain its attitude of the flight.	About 66 hours	**
July 20, 2009	15 km south-east of Tajima Airfield	Robinson R44II (JA32CT)	Crash into the forest	It did not notice its approaching the mountain while avoiding clouds.	About 17 days	Inoperable (Antenna broken, ELT burnt)
July 28, 2010	Matsumae Dist., Hokkaido	Cessna TU206G (JA3902)	Crash into the mountain ridge	Unable to visibly confirm the ground surface, it flew at less than the minimum safety altitude.	About 47 hours	Operable (Antenna broken) A SAR aircraft received the emergency

						signal.
January 3, 2011	Slope on Mt. Yagoyama. Kumamoto Pref.	Piper PA-46- 350P (JA701M)	Crash into the mountain slope	It flew in clouds.	About 22 hours	Operable An aircraft flying nearby received the distress signal.
July 26, 2011	The Suruga Bay	Extra EA300/200 (JA22DB)	Crash into the sea	It might fall into vertigo because of bad weather conditions.	About 5 hours (Parts of the fuselage were found)	(ELT not on- board)
July 28, 2011	Kasai Dist., Hokkaido	Beechcraft A36 (JA4215)	Crash into the mountain slope	It approached clouds or flew into clouds.	About 4 hours	Operable The SAR satellite received the distress signal from the Aircraft.
March 15, 2013	Kasai Dist., Hokkaido	Hoffmann H- 36 Dinamo (JA2405)	Crash into the mountain slope	It encountered downdrafts blowing from the mountain ridge.	About 65 hours	Inoperable (Switch OFF)
March 5, 2014	Toyota City, Aichi Pref.	Cessna 172M Ram (JA3853)	Crash against a tower	Avoiding clouds, it flew at less than the minimum safety altitude.	**	**
November 22, 2015	Annaka City, Gunma Pref.	Robinson R22Beta (JA7963)	Crash into the mountain slope	Unable to maintain the visual meteorological conditions, it flew at lower altitude.	Immediately found	**

**indicates the matters that were not be able to be confirmed since there were no descriptions in the accident investigation report.

2.18.2 Recommendations in Past Similar Accidents and Incidents

In September, 2012, The Japan Transport Safety Board (JTSB) published the aircraft accident investigation report (AA2012-7-2) on a privately owned Piper PA-46-350P, registered JA701M. In this investigation report, presuming that the aircraft collided with the mountain slope because it climbed during its in-cloud flight under VFR, the Japan Transport Safety Board referred to other four similar accidents of small airplanes (including rotorcraft), which occurred due to flying in-cloud on the VFR flight for five years before publishing the investigation mentioned as above, and recommended the Minister, MLIT to publicize the following contents to the pilot associations and make them known to a pilot individual using the opportunities of the Review System on Specific Pilot Competence.

- (1) Take its departure only when it is judged as possible to maintain VMC all across the enroute based on the latest weather information.
- (2) Prepare alternative plan in case of deteriorating weather while intermittently collecting

weather information on enroute.

- (3) Decide well in advance on returning to the departed airport or landing at a proper place.

Upon the receipt of this recommendation, in December, 2013, the Japan Civil Aviation Bureau of the MLIT decided that in addition to continuing previous advices, they should produce a pamphlet to have an individual pilot be newly aware of the hazardousness of the in-cloud flight under VFR, and distribute those pamphlets to make those contents known to an individual pilot by using the opportunities of the Review System on Specific Pilot Competence and others.

2.19 Additional Information

2.19.1 Flight Plan Chart

After the accident, the flight plan chart of the Aircraft was found inside the Aircraft, while the Prefectural Police Mountain Ranger was collecting its fuselage and other parts. In this charts, two routes were described for the outward journey (Matsumoto Airport to Toyama Airport) and for the homeward journey (Toyama Airport to Matsumoto Airport), respectively.

Outward Journey (Matsumoto Airport to Toyama Airport)

Plan A: Matsumoto Airport - Islands - Nagawado Dam - Funatsu - Sasazu - Toyama Airport
(Crossing the mountains)

Plan B: Matsumoto Airport - Omachi - Mt. Myojisan/Mt. Kurohimeyama (Itoigawa) - Uozu
- Toyama Airport

Homeward Journey (Toyama Airport to Matsumoto Airport)

Plan A: Toyama Airport - Kamidaki - Murodo - Kurobe Dam - Omachi - Matsumoto Airport
(Crossing the mountains)

Plan B: Toyama Airport - Uozu - Mt. Myojisan/Mt. Kurohime (Itoigawa) - Omachi -
Matsumoto Airport

Among those flight plans, Figure 10 shows the copied homeward journey Plan A relating to the accident. In addition to those key point targets like Kamidaki, Kurobe Dam and Omachi as well as the direction and distance of each flight sector, this flight Plan A described the planned flight altitude, frequencies / Morse codes of Toyama VOR (TOE) and Matsumoto VOR, Call sign / Frequencies (OFF SIDE / 133.9) concerning the Airspace of Self Defense Forces High Altitude Training / Test Areas (described in 2.19.3), and frequencies of air traffic control facilities like Toyama Tower (TWR) and Matsumoto Radio (RDO).

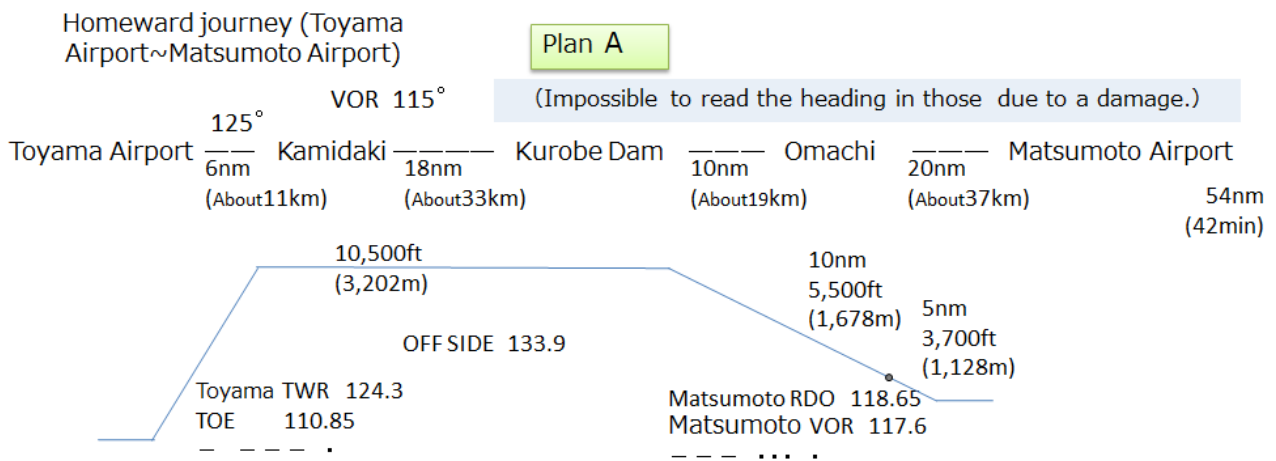

Figure 10: The Homeward Journey Flight Plan Found inside the Aircraft (Copied by JTSB)

The division aeronautical map⁴¹ shown in Appended Figure 1 was found at the time of collecting the fuselage. This chart put “Mt. Tateyama: 9,892 ft” and “Mt. Washi-dake: 8,613 ft” as mountains involved in the flight route of the homeward journey, however, did not clarify the height of each mountain noted in Appended Figure 4.

2.19.2 The SNS Posting by the Pilot and Photos Taken in the Aircraft

At 11:21 on June 3, the Pilot posted the photos taken immediately after its takeoff from Toyama Airport with the SNS message saying, “My first landing in Toyama Airport in a long time. We could not cross the mountains because the weather is not fine so much.”

In Passenger B’s smartphone, there were photos (Photo 11), which shot the scene of outside window, taken at 14:45:28. Based on this shooting time, it is probable that those photos might be taken between [Point d] and [Point e] shown in Appended Figure 4. As the scene of outside window was invisible with coming out in all white around them in Photo 11, any clues about where the Aircraft was flying at that time was not confirmed, however, it was able to read the IAS (Indicated Airspeed): 65 KT, Attitude: pitch angle 5° UP, left bank 15°, Pressure altitude: 8,650 ft. Although the VSI cannot be confirmed with this Photo 11, but according to the manufacturer of the same type of aircraft, it is presumed that the estimated rate of climb at that time was +280 fpm.

On the other hand, Icing can be confirmed on the vent port of fuel tank and the lower surface of Aircraft’s left window. Photo 12, which was taken at the almost same time with Photo 11, shows the lower surface of Aircraft’s right wing. In the enlarged photo⁴² of the right wing strut, icing can be clearly confirmed.

In addition, Photo 11 shows that The Pilot does not fasten his shoulder harness.

⁴¹ The division aeronautical map (published by the Japan Aircraft Pilot Association) is an airlines reference map useful for VFR open air flight.

⁴² Color gradation is provided in the “Enlarged Photo” in order to make clear the icing conditions.

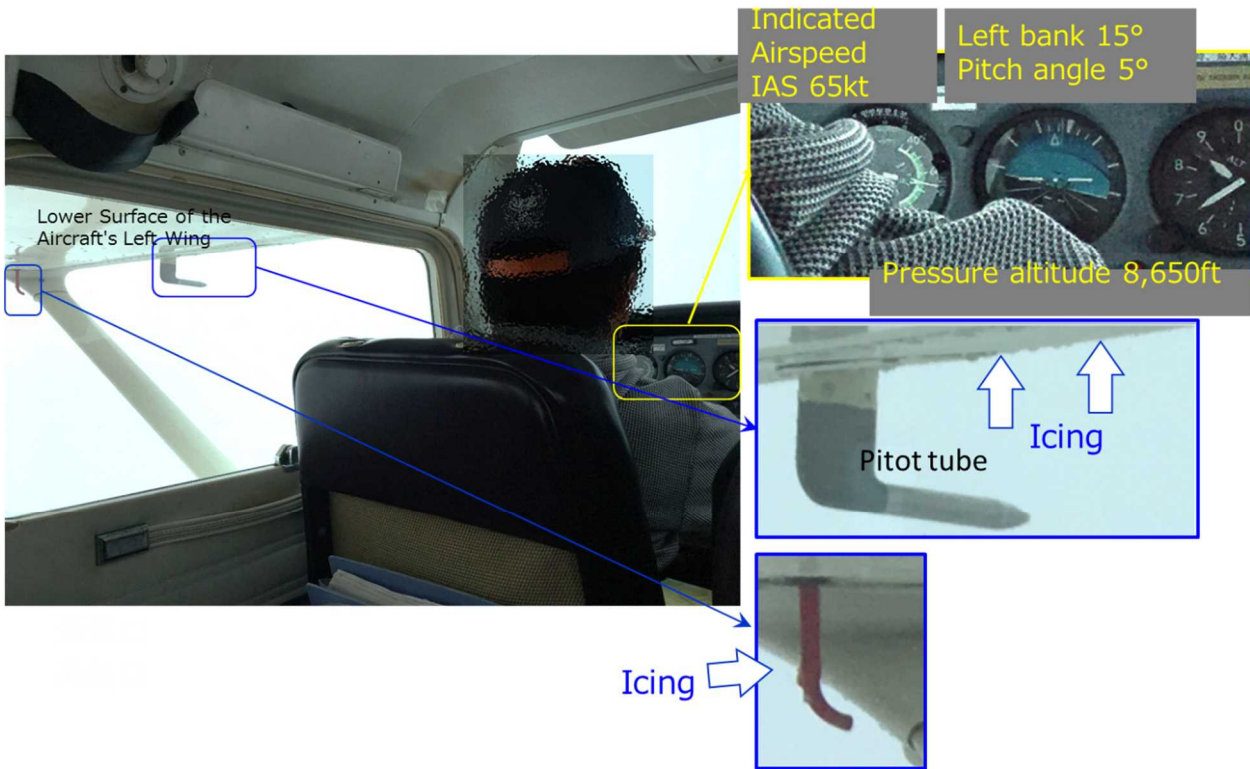

Photo 11: Pictures Left in Passenger B's Smartphone

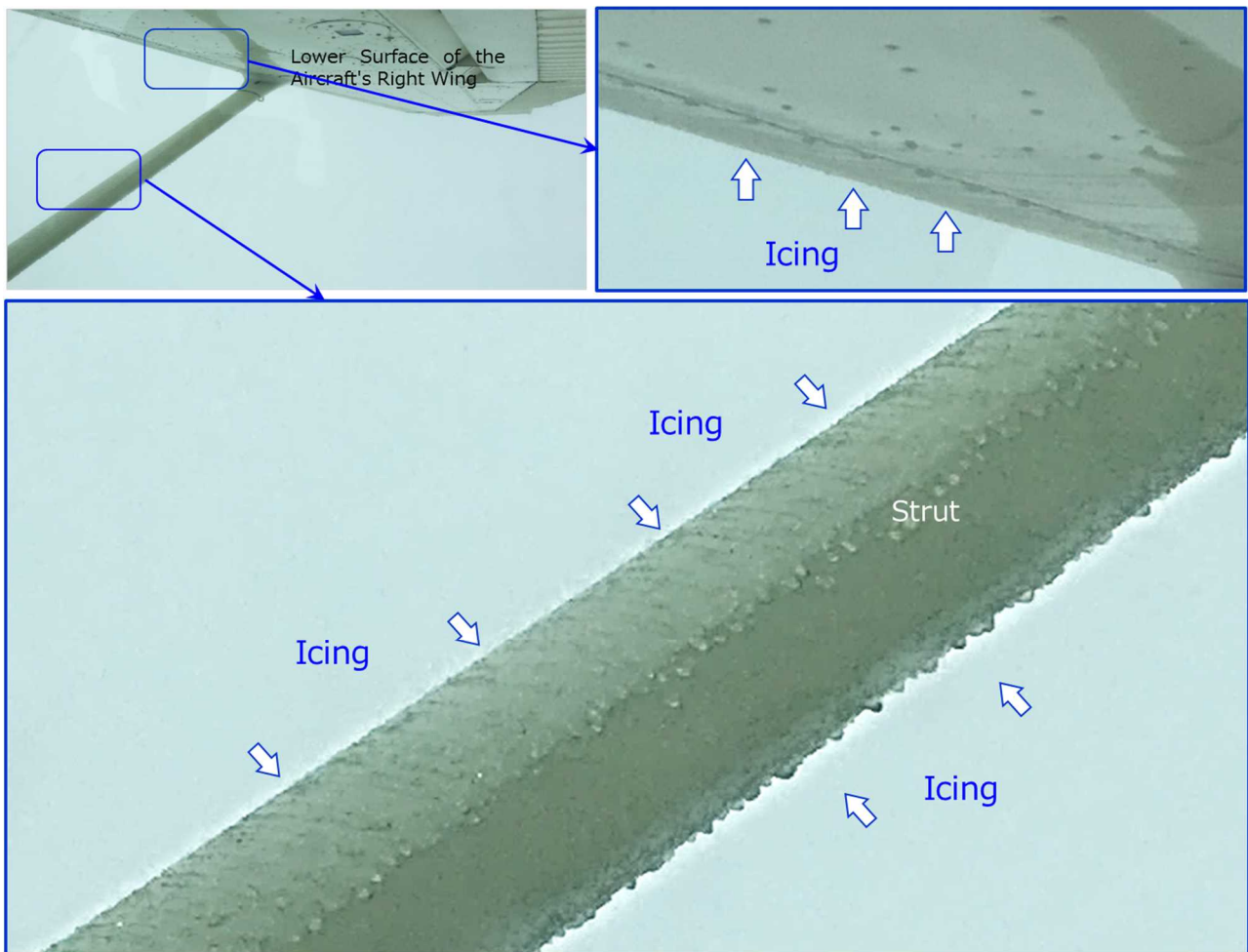

Photo 12: Enlarged Photo of the Leading Edge and Strut of the Right Wing

2.19.3 J-3 JSDF Training / Testing Areas

The AIP Japan contains the following descriptions about the airspace of J-3 JSDF Training / Testing Areas⁴³. (excerpts)

When Training / Testing aircraft other than JSDF's aircraft use any of these airspace, coordination should be made with Chief of Controlling Unit of the airspace. Aircraft fling for the purpose other than training / testing should not enter this airspace without prior coordination with Controlling Unit.

As shown in Appended Figure 1, it is probable that after taking off from Toyama Airport, the Aircraft flew to the east, passed the J-3 JSDF Training Testing Areas, and tried to cross the Tateyama Mountain Range. In case of crossing the Tateyama Mountain Range, in compliance with the AIP, a prior approval should be obtained from the Controlling Unit of the Ministry of Defense which has jurisdiction over the relevant airspace.

On the morning of the day of the accident, the application for the permission to fly through the J-3 JSDF Training / Testing Areas was made on the phone and the permission was given.

According to the Ministry of Defense, the contents were summarized as follows:

Time to Fly: 14:45 to 15:15

Flight Route: From Toyama to Matsumoto

Flight Altitude: Any Altitude between 9,500 ft to 11,500 ft

2.19.4 Altimeter Errors on Mountain Flights

A literature titled "The Aviation Meteorology Introduction⁴⁴" describes about the altimeter indication errors cause by air currents on mountain flights as follows:

On mountain flights, the altimeter indication errors occur due to the effects produced by the air currents over the mountaintop. It is assumed that the expression of statics is established in case of calibrating the altitude by means of the standard atmosphere. However, in the event of the calibration for air currents on mountain flights where the vertical acceleration of the flow cannot be omitted compared to the value of G, the expression of statics cannot be applied. (omitted) On flying over mountainous regions where strong downdrafts blow along the mountain slope, the readings on the altimeter would become higher than the real altitude, which possibly led to the crash if the aircraft approaches to the mountain slope.

2.19.5 Use of Shoulder Harness

The Flight Service Operation Rules: 4-2 Flight Operating Procedure in the Company stipulates that the safety belt (Seat Belt and Shoulder Harness) shall be always used in piloting aircraft and all occupants shall be advised to fasten the safety belt all the time.

The FAA's home page contains the following descriptions about the use of a shoulder harness by occupants on the general flight of small aircraft

The distressing fact is that roughly one-third of general aviation accidents with fatalities are deemed survivable. (omitted) In these events, the crash forces themselves do not kill the pilot. The

⁴³ The J - 3 JSDF Training / Testing Areas are described in AIP ENR 5. 2-4. 133.9 MHz (Call Sign: OFF SIDE) is the frequency for the chief of Controlling Unit of the airspace of J - 3 JSDF Training / Testing Areas

⁴⁴ The first edition of "the Aviation Meteorology Introduction (written by Hiroshi Ito)" was published in June, 1973 from the Tokyo.

fatality results from an abrupt encounter with the airplane controls or the panel. Both fatalities and serious injuries can be greatly reduced by proper use of a shoulder harness.

Recommendations

Pilot Actions

- *Use your shoulder harness! You can remove it when such use interferes with cockpit duties.*
- *Be sure Fasten Shoulder Harness is on your preflight checklist.*
- *Check that all crew and passenger shoulder harnesses are fastened before takeoff and before landing.*

3 ANALYSIS

3.1 Qualification of Personnel

Both PIC and the Pilot held valid airman competence certificates and valid aviation medical certificates.

3.2 Aircraft Airworthiness Certificate

The Aircraft had a valid airworthiness certificate and had been maintained and inspected as prescribed.

3.3 Relations to the Meteorological Conditions

As described in 2.6.1, the meteorological conditions at 14:00 on the day of accident at Toyama Airport, which was a departure airport on the homeward journey, was that with light northwesterly wind, visibility was 10 km or more, the sky was covered with scattered clouds at 2,500 ft, and the cloud base height was at 10,000 ft. On the other hand, it is probably that it was windy a little but Visual Meteorological Conditions (VMC) were maintained at 14:00 at Matsumoto Airport that was a destination on the homeward journey on that day. Therefore, it was probable that the meteorological conditions at both of those airport did not have any problem taking off and landing.

On the other hand, as shown in Appended Figure 12: Significant Weather Prognostic Chart of Lower Layers, in the east of Toyama Prefecture, it was forecast that there would be clouds of about 3,000 – 6,500 ft AGL, a humid air area around 5,000 ft above Toyama Airport, and the temperature of an altitude of 10,000 ft would be -4°C. In addition, as described in 2.6.2.2, it was confirmed with the image taken by the live camera during 13:00 to 15:00 that the top of the Tateyama Mountain Range was covered with clouds. And as shown in Photo 2 to 6, it is probable that during the time period when the accident occurred, all around the area where the Aircraft flew through was invisible and covered with fogs and clouds. As described in 2.16.1.3 “FAA Document: Tips on Mountain Flying”, it is recommended that pilots should have at least 15 miles (about 24 km) of visibility before attempting mountain flights. Therefore, it was anticipated that under those weather conditions, this mountain flight would be difficult for the Aircraft at the time of taking off from Toyama Airport.

As shown in Appended Figure 11: Hourly-Analysis Chart at 9,000 ft at 15:00 on June 3, 2017, westerly wind at about 30 kt was observed in the vicinity of the accident site. And as shown in Appended Figure 12: Significant Weather Prognostic Chart of Lower Layers, the westerly wind was also forecast at about 30 kt at an altitude of 10,000 ft. In addition, as described in 2.6.2.5, a

scheduled flight pilot also reported that the wind direction was 350° and the wind speed was about 35 kt at an altitude of 10,000 ft in the vicinity of the Tateyama Mountain Range. As described in 2.16.1.3 “FAA Document: Tips on Mountain Flying”, it is probable that it is important for pilots on mountain flying to make sure the information on winds in the upper air, and to predict in advance the possibility of encountering turbulence in the vicinity of the mountaintop, which is described in 2.16.2 “FAA AC Aviation Weather”.

Based on the above, probably, before its departure, it was anticipated that it would be difficult for the Aircraft to maintain VMC on this flight route and it is also probable that they should have considered the possibility of icing encounter as described in 2.15.1, and the effects from turbulence in the vicinity of the mountaintop as in 2.16.1.3 and 2.16.2.

3.4 Judgment before Departure

3.4.1 Flight Plan of the Aircraft

As described in 2.19.1, the Aircraft’s flight plan chart, which had two plans (Plan A / Plan B) for the outward and homeward, respectively), was found inside the Aircraft. It is probable that this flight plan chart was prepared by the Pilot for the flight on the day of accident. The Pilot prepared mountain flight courses as Plan A for both outward / homeward, but as shown in Appended 1, for the outward journey on that day, they chose Plan B (via Itoigawa) that was not mountain flight course. As described in 2.1.2 (2), it is somewhat likely that this was because the PIC had planned to fly via Itoigawa City on outward journey for Toyama Airport a day before the day of the accident as well as he also considered that the mountain flight on outward journey would go against a head wind, since in the weather forecast, the west-northwest winds at 30 kt was predicted over the Tateyama Mountain Range. As described in 2.19.2, the Pilot posted his SNS message saying, “We could not cross the mountains”, as having chosen the Plan B for their outward journey. Therefore, it is somewhat likely that he wished to cross the mountains on homeward journey.

As described in 2.19.3, on the morning of the day of the accident, the PIC had applied for permission to fly through the J - 3 JSDF Training / Testing Areas in the afternoon, and he had tentatively decided to cross the Tateyama Mountain Range via Murodo on homeward journey. It is somewhat likely that as an instructor for the Pilot, who was his student and client, the PIC would respect the Pilot’s wishes to cross the mountains on homeward journey.

3.4.2 The Aircraft’s Departure Decided by the PIC and the Pilot

As shown in 2.6.2.2 and 2.6.2.3, it was confirmed with the images taken by live cameras on the morning of the day of the accident that in the morning, the meteorological conditions in the Tateyama Mountain Range were generally favorable enough to command a view of Lake Kurobe in the east of the mountain range. As shown in 2.6.2.4, it was also confirmed with the images taken by the live camera in Omachi that the weather conditions were generally good over the Ushiroateyama Mountain Range and Omachi city. As shown in Appended Figure 1, it is somewhat likely that the PIC and the Pilot thought it would be possible to cross the mountains on homeward journey when they confirmed the clouds condition over the Ushiroateyama Mountain Range on outward journey.

As described in 2.1.2 (3), before taking off from Toyama Airport, the PIC consulted a website for meteorological information at the Toyama Airport Flight Operation Support. It is somewhat likely that the PIC recognized lots of clouds in the vicinity of the Tateyama Mountain Range by

confirming the latest images taken by live cameras installed in place on the planned flight route, which was described in 2.6.2. On the other hand, according to the numerical analysis detail shown in the Figure 2 ② of 2.6.2.8, at around 15:00 when the accident occurred, the humid air area existed in the west side of the Tateyama Mountain Range. But in the east side, no remarkable humid air area confirmed, which indicated the possibility that there were fewer clouds in the east side of the Tateyama Mountain Range than the west side of that. It is somewhat likely that the PIC, who was well familiar with the meteorological conditions in the mountain regions, made the same prediction about the weather.

It is somewhat likely the basic idea behind their psychologically biased decision-making on the departure was that the PIC and the Pilot wished to cross the mountains on homeward, since they could not do it on outward, and that they had already submitted the flight plan including mountain flight routes. In other words, it is also somewhat likely that they might determine to manage to cross the Tateyama Mountain Range through Omachi for Matsumoto Airport, assuming that the weather conditions and visibility in the east side of the mountains would be better than those in the west side although there were lots of clouds around the Tateyama Mountain Range, or they might think flying close to the Tateyama Mountain Range for a while anyway in spite of the bad weather condition there, and then, turning back depending on the situation.

It is probable that the PIC and the Pilot should have decided to abandon the plan of crossing the Tateyama Mountain Range before departure by taking into consideration the meteorological conditions described in 3.3 and placing a priority on safety.

3.5 History of the Flight

3.5.1 Takeoff From Toyama Airport Up To Flying Over the Mountains

As described in 2.1.1, the Aircraft took off from Runway 02, Toyama Airport at 14:23. It is somewhat likely that at this time, the Pilot in the left front seat was flying the Aircraft. As described in 2.1.2 (3), an ATC officer at Toyama Airport Flight Service Center saw the Aircraft flying toward the east avoiding clouds. It is probable that the Aircraft flew from Toyama Airport through Kamidaki, maintaining VMC during climbing toward the Tateyama Mountain Range.

As shown in Appended Figure 2, after the Aircraft turned left at 360° two times at [Position a] at around 14:30 to 14:34, it also turned left at 360° one time at [Position b] at around 14:37 to 14:40. Probably, it is because it had to obtain height in order to reach the altitude necessary to cross the mountains by taking 360° turns, since the strong westerly winds were blowing during the flight.

The Aircraft planned to fly from Kamidaki to Murodo, but as shown in Appended Figure 2, it did not fly from [Point b] toward Midagahara / Murodo, and it changed to go on a southerly route. It is probably because as described in 2.6.2.2, the Tateyama Mountain Range was covered with clouds as shown in the images taken by a live camera at Position B in Figure 1 at the time of the occurrence of the accident. Midagahara and Murodo were entirely covered with clouds as shown in Photo 1 and Photo 3.

As shown in the images taken by each live camera installed in place, which was described in 2.6.2, it is probable that fogs and clouds covered over the Aircraft's flight route from [Point b] forward. Therefore, judging that there was the possibility that the meteorological conditions in the east side would be better than those in the west side, the Aircraft tried to cross the Tateyama Mountain Range and go to the east side. And as shown in Appended Figure 4, it is probable that

the Aircraft flew via the valley in the Tateyama Caldera and changed heading to southeast at [Position c] at 14:43:38 to go over the Etchuzawanokoshi (7,728 ft; 2,356 m) whose elevation is lower than surrounding mountains.

It is somewhat likely that in a state of low visibility, the Pilot might continue to fly the Aircraft with advices from the PIC who had the Instrument Flight Certificate and the PIC might take a turn to fly the Aircraft.

3.5.2 Flight Situation of the Aircraft after Deciding on Turning Back

As shown in Appended Figure 4, the Aircraft passed through the Etchuzawanokoshi, flew over the Tateyama Mountain Range and reached [Position d] at 14:45:08. However, as shown in Appended Figure 2, after flying to the east side of the Tateyama Mountain Range, the Aircraft turned back at once. As to be described in 3.7, it is probable that around the time when the Aircraft commenced to cross the mountains, it would get into in-cloud flight without being able to avoid clouds. Besides, it is also probable that the PIC and the Pilot noticed the ice build-up on the Aircraft and tried to turn back.

It is probable that although the Aircraft tried to turn left at 180° the Aircraft, it found the mountains' west side covered with clouds, therefore, again at [Position e] in Appended Figure 4, it was flying substantially changing its route by turning left and right while looking for clouds rifts.

As described in 2. 19. 2, Photo 11 was taken at [Position p] in Appended Figure 4 at 14:45:28. In this picture, the scene of outside window was invisible with coming out in all white, and the mountaintop cannot be confirmed. Therefore, it is probable that while flying in clouds, it became difficult for the PIC and the Pilot to grasp its own position and surroundings by confirming visually the terrain.

As shown in Appended Figure 4, it is probable that passing through [Point f] at around 14:47:30, the Aircraft flew to the north and at around 14:50, crashed into the southeast mountain slope of Mt. Shishi-dake in the Tateyama Mountain Range. It is somewhat likely that contributing factors, such as failure to avoid the crash due to the loss of visual contacts, or due to failure to maintain safe altitude because of the flight performance deterioration caused by the aircraft icing or stalled condition, or due to difficulty inflight controls caused by encountering severe turbulence, led to the Aircraft crash into the mountaintop after approaching to its vicinity. However, it could not be determined, since the PIC and all members on board were fatally injured.

3.5.3 The Aircraft Sliding Down on Snowy Surface after the Crash

As shown in 2.7.1.2 and Appended Figure 6, on the south eastern snowy slope (elevation about 2,700 m) about 10 m downhill from the mountain ridge of Mt. Shishi-dake, the contact marks when the Aircraft had likely slid down the slope were left. Beside those marks, there were the broken nose gear and others. It is probable that those marks indicate that the vicinity of the top of Mt. Shishi-dake was its first contact site.

In addition, based on the marks left on the snowy surface, it is somewhat likely that the Aircraft collided with the rock ridge after crashing into the vicinity of the mountain ridge and afterward slid down the snowy slope to the valley. It is also somewhat likely that as shown in Appended Figure 7, while sliding down the slope, the engine was detached from the fuselage, impurities like sand were included inside the detached engine. It is probable that the fuselage further slid down the slope and came to a halt at around [Position y] in Appended Figure 4.

As described in 2.7.3, the settings of the frequencies were not identified and it was not confirmed whether the PIC tried to make an emergency call on frequency 121.5 MHz since the cockpit panel for NAV/COM was broken. The reason why the transponder Code was found set at 0000 at the time of the discovery of the Aircraft is likely that the numeric set lever was lowered at the time of crash and its flap lever was also crashed into the Dawn position on impact at the time of crash or sliding down the slope.)

3.6 Decisions on Turn Back When Weather Deteriorates Enroute

As described in 2.16.1.5, “FAA Document: Tips on Mountain Flying” states that when the weather deteriorates enroute, the urge to continue is very strong for most of pilots, with the thought that it will get better if we just continue a little farther. However, continuing is often the worst thing you can do.

As described in 2.1.2 (5), 2.6.2.5 and 2.6.2.6, the pilots, who were flying other airplanes in the vicinity of the Tateyama Mountain Range during the time period when the accident occurred, reported about the clouds covering in the vicinity of its mountaintop. In addition, as confirmed with the live camera described in 2.6.2.3, there were no air space for an aircraft to be able to fly between the mountaintop and the cloud base. As described 3.4.2, it is somewhat likely that the PIC and the Pilot assumed that the weather conditions and visibility in the east side of the Tateyama Mountain Range would be better than those in the west side and the situations would turn for the better if they flew beyond the mountains to the east, or that they would turn back depending on the situation.

However, as described in 3.5.2, it is probable that around the time when the Aircraft commenced to cross the mountains, it got into in-cloud flight and encounter icing condition. It is probable that the PIC and the Pilot should have decided to turn back without hesitation by placing a priority on safety, when they witnessed the conditions of fogs and clouds covering over the mountains before commencing to cross the Tateyama Mountain Range.

3.7 Icing of the Aircraft

3.7.1 Icing Encounter

As described in 2.13.3, the Aircraft is not certificated for flight under the weather condition where icing conditions are predicted. As described in 2.15.1, it is recommended that if an aircraft is not certificated for flight in icing conditions, in the event of an inadvertent icing encounter, the pilot should take appropriate action to exit the conditions immediately. In addition, as described in 2.15.3, it is stated that icing is more likely and more severe in mountainous regions, and icing with mountains can be especially hazardous because a pilot may be unable to descend to lower air space to have the ice melting due to terrain elevation even if the pilot notices icing in mountain regions.

As described in 2.15.1, “FAA Flight in Icing Condition” states that nearly all aircraft icing, which affects aerodynamic performance, occurs in supercooled clouds, and ice accumulation is often greatest at temperatures not too far below 0 °C (32 °F), where LWC can be abundant. Judging from the fact that during the time period when the accident occurred, the cumulus-like clouds covered over the vicinity of the Tateyama Mountain Range, and as shown in 2.6.2.7, the temperature at the top of Mt. Jodosan (elevation about 9,300 ft) was -1.7°C, it is probable that the temperature at an altitude of 8,550 to 8,750 ft where the Aircraft was flying was likely around 0°C. Therefore, it is highly probably that around the time when commencing to cross the

mountains, the Aircraft got into in-cloud flight without being able to avoid clouds, and as shown in Photo 12 of 2.19.2, the ice accumulation was produced on the main wings and others, which likely made an effect on the flight performance of the Aircraft.

It is somewhat likely that the PIC and the Pilot recognized an icing encounter and tried to turn back by following the “Check List for Inadvertent Icing Encounter” described in 2.13.3, since as shown in 2.7.3, the pitot tube heater, the carburetor heat, the cabin heat control of the Aircraft were all set to ON.

3.7.2 Effects of the Aircraft Icing

Judging from the investigation results after the accident, which revealed that as shown in 2.7.3, the pitot tube heater was set to ON, the icing on the pitot tube was not confirmed as shown in Photo 11 of 2.19.2, and alternate static pressure hole was set to OFF with not switched to ON, it is probable that at this point, the icing was having no effects on the Aircraft’s flight instruments such as the speed indicator and the altimeter. In addition, the PIC and the Pilot were being able to look out of window since in Photo 11 of 2.19.2, the cabin heat control of the Aircraft was set to ON and no significant icing was confirmed on the window shield and side windows.

On the other hand, as described in 2.15.2, icing can have dramatic effects on stall speeds stability, and control, the Angle of Attack (AOA) at which a stall occurs (the stall angle) is much lower with ice, the Maximum Coefficient of Lift (CL_{max}) is significantly reduced from a relatively small ice accretion, and drag tends to increase steadily as ice accretes.

As shown in Appended Figure 4, the altitude of the Aircraft at [Position p] was at 8,650 ft at 14:45:28, and as described in 2.19.2, the manufacturer suggested that pitch angle 5° in this atmospheric state should be equivalent to the rate of climb +280 fpm, however, 20 seconds later, the altitude of the Aircraft was at 8,550 ft at 14:45:48, which means that the Aircraft did not climb. On the other hand, according to the flight plan described in 2.1, the cruising speed of the Aircraft was at 95 kt (TAS), and it would be 83 kt (IAS) at an altitude of about 9,000 ft / temperature at 0°C, but the Aircraft flew at 65 kt (IAS), which is 20 kt lower than its planned speed, as shown in Photo 11. Therefore, it is also somewhat likely that the flight performance of the Aircraft was significantly deteriorated and it became impossible for the Aircraft to maintain the altitude due to the aircraft icing.

Besides, the carburetor heat was being used, but it is also highly probable that the carburetor icing or the icing on the engine suction port might have effects on the engine performance.

Furthermore, Table 3 in 2.13.2 shows that when the Aircraft’s angle of bank is at 0°, its stall speed is 44 kt. However, it is the stall speed when the aircraft surface is smooth without any icing on it. The stall speed can be greater than 44 kt depending on the degree of the Aircraft icing conditions. Therefore, the more ice accumulation, the more increasing the possibility to get into a stall even if the aircraft is in a stable flight, and at the time of encountering turbulence and making turns at a deep bank, the risk of a stall could be higher. It is also somewhat likely that the Aircraft encountered the turbulence in the vicinity of the mountaintop, or stalled due to its turning left and right in order to avoid the crash into the mountaintop.

3.8 Possibility of Encountering Turbulence in the Vicinity of the Mountaintop

As described 2.16. 1. 3 and 2.16.2, turbulence around the mountaintops often produces violent downdrafts on the immediate leeward side of the mountain barrier, and sometimes the downward

speed exceeds the maximum climb rate of an aircraft and may dive the aircraft into the mountainside. It is also stated that mountain flying should not be attempted if the winds aloft forecast at mountain top levels are greater than 25 knots.

As described 2.16.1.4, “FAA Document: Tips on Mountain Flying”, if the winds at mountain top level are above 20 knots, pilots should fly at the mountaintop elevation plus at least 2,000 feet and plan to be at that safety altitude at least three miles before reaching the ridge and stay at that altitude to avoid the most severe turbulence.

As shown in Appended Figure 12: Significant Weather Prognostic Chart of Lower Layers, during the time period when the accident occurred, the westerly wind was forecast at about 30 kt at an altitude of 10,000 ft. In Appended Figure 11: Hourly-Analysis Chart at 9,000 ft at 15:00 on June 3, 2017, westerly wind was observed in the vicinity of the accident site. In addition, it is probable that straddling north and south, and having topographic features specific for caldera with a great altitude deference from its surrounding areas, the Tateyama Mountain Range was then the area in which turbulence tended to be generated when strong westerly winds blow, and any aircraft should not have flown in the vicinity of its mountaintop.

It is also somewhat likely that as getting into in-cloud flight with difficulty to grasp its own position, the Aircraft was forced to fly at non-safety altitude, unable to keep enough altitude away from the ridge, and crashed into the mountain after encountering severe turbulence.

3.9 Performance of the Aircraft

As described in 2.13.2 (1), in the POH, the service ceiling of the Aircraft is 13,000 ft. However, as described in 2.16.1.2, “FAA Document: Tips on Mountain Flying”, mountain flying presents demands on the airplane that may require high performance and the aircraft gross weight and its effect on performance should be carefully considered.

As described in 2.1.2 (4) and (5), the club members and a small airplane pilot estimated that it would be difficult to cross the mountains at 10,000 ft or more by the same type of aircraft with four occupants on board, and as for the performance of the same type of aircraft, they expressed a concern whether it could safely cross the mountains even if it were fine.

As described in 3.3, during the time period when the accident occurred, the Tateyama Mountain Range was covered with clouds, the winds aloft were strong and a precaution against turbulence was required. According to FAA Document: “Tips on Mountain Flying”, the Aircraft should have flown at the altitude of mountaintop elevation plus 2,000 ft or more. It is somewhat likely that as its weight reached closed to allowable maximum weight with four occupants on board, the Aircraft could not maintain the safe altitude sufficiently enough to easily cross the Tateyama Mountain Range where strong winds blew and clouds covered over.

3.10 Healthiness of the Aircraft

As described in 2.7.3, the investigation conducted after the accident revealed that no traces of faults were confirmed in the Aircraft control system, but impurities such as sand, water and lubricating oil were found in parts of engine inside. However, this is because, as described in 3.5.3, while the Aircraft’s sliding down the slope, its engine was detached from the fuselage, and impurities like sand were included inside the detached engine. No traces of faults were found in other parts of the engine.

The manufacturer of the propeller informed that the propeller bent forward indicated the low rotational energy absorption during the impact sequence. As shown in Figure 11, it is somewhat

likely that at the time of the accident, the Aircraft touched down first with the left main landing gear and the nose landing gear, and crashed into on the snowy mountain slope. It is highly probable that the rotating propeller touched the soft snowy surface, which made the speed of rotation reduced, and the rotation energy became lower and the propeller was bent forward. As described in 3.7.2, it is also somewhat likely that the performance of engine might have been affected by icing, but the propeller had been rotating just before the Aircraft crashed into the snowy slope.

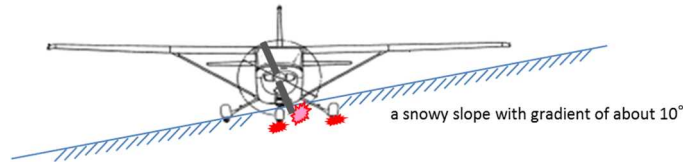

Figure 11 Crash Scene (Estimated)

3.11 Need for Emergency Communication

As described in 3.5.2, it is probable that the Aircraft under Visual flight Routes got into in-cloud flight and into icing conditions subsequently. Those are emergency situations where an aircraft under VFR gets into in-cloud flight inadvertently and cannot get out of the clouds in spite of trying to turn back, or an aircraft like the Aircraft not allowed to fly in icing conditions, encounters an inadvertent icing.

As described in 2.9, during the time when the accident occurred, there were no records to have received the emergency code “7700” by transponder, and records of the emergency communication by voice were not confirmed. Therefore, it is probable that the PIC and the Pilot did not clearly recognize that they had fallen into an emergency situation. As described in 2.13.1, the Company's Operation Service Procedure specifies that in case of an emergency situation or a distress, the PIC shall make an emergency communication. The PIC should have sent the emergency code “7700” by transponder that is necessary at the time of search and rescue operations for an aircraft in distress, and he should have notified relevant organizations and airplanes flying nearby the position of the Aircraft by using emergency frequency 121.5 MHz to ask support from them.

3.12 ELT

3.12.1 Operation Status of ELTs and Reception Status of Emergency Communications

As described 2.17.2.3, according to the function test (state investigation) of the ELT installed on the Aircraft, it was capable of normally functioning even in a low-temperature circumstance and the ELT's transmission outputs of 121.5 MHz, 243 MHz and 406 MHz also functioned normally.

The prefectural police mountain ranger stated that the ELT switch was set to ON when discovering the Aircraft. It is probable that Passenger A or Passenger B might switch ON according to the advice from Mechanic A about the ELT operation. Therefore, it is highly probable that the ELT certainly commenced to transmit a distress signal when it was switched ON.

It is probable that the ELT continued to transmit a distress signal for about 18 hours from around 15:00 on June 3 when the accident occurred to around 09:00 on June 4, because, as described in 2.17.2.1, the ELT on the Aircraft was able to transmit a 406 MHz emergency signal

every 50 seconds and the number of transmissions was 1,310 times. However, as described in 2.7.2, as the auxiliary antenna for the ELT was broken with a snap, the SAR satellite was not able to listen on the 406 MHz emergency signal transmitted from the ELT. And as described in 2.9, it is probable that on June 3, the SAR aircraft was not able to receive the distress signals on the frequencies 121.5 MHz and 243 MHz. Regarding the fact that a SAR aircraft of the Defense Ministry received a distress signal on the following day, June 4, it is somewhat likely that after checking the items in the Aircraft including the ELT, the mountain ranger might move those things lying on the floor onto the seat, and take those items out of the Aircraft, since when the SAR aircraft received the distress signal on June 4, the rescue operation by the mountain ranger had already started.

3.12.2 Instructions on Installation and Operation in the ELT Manufacturer's Manual

As described in 2.17.2.1, the ELT mounted on the Aircraft is required to be equipped as the Automatic Portable ELT (AP) in accordance with the ELT manufacturer's manual. In addition, the manufacturer's manual describes that the Automatic Portable ELT (AP) can be used as a Survival ELT, specifying that without installing in the ELT main body, the auxiliary antenna shall be secured to the main body with a hook loop fastener as shown in Figure 9.

However, as described in 2.17.2.2, in the Company, the ELT bracket was just put in the Aircraft's fuselage and not secured there, and the ELT unit was stowed in the aircraft's rear storage area. And as shown in Photo 10, when the ELT unit was used, the auxiliary antenna was left connected to the ELT main body. Therefore, it is probable that the auxiliary antenna of the ELT on the Aircraft was broken with a snap on the impact of the crash. The Company should install and operate the ELTs for the Aircraft according to instructions in the ELT manufacturer's manual.

It is somewhat likely that if the Company installed and operated the ELT for the Aircraft according to instructions in the ELT manufacturer's manual, the ELT's auxiliary antenna would have not been broken with a snap, and by connecting the antenna to the ELT main body, the SAR satellite could have received the 406 MHz emergency signal transmitted from the ELT and swiftly sent the place of a distress of the Aircraft to the SAR members on the ground and the SAR aircraft. And at the same time, the SAR aircraft would have been able to directly receive those emergency signals on the frequencies 121.5 MHz and 243 MHz transmitted from the ELT of the Aircraft. It is also somewhat likely that if the weather was favorable, the SAR aircraft would have been able to spot the Aircraft much earlier, following and tracing the emergency communications from the ELT of the Aircraft.

3.12.3 Appropriate Operation of ELTs

As described in Table 6 in 2.18.1, among the similar accidents of small airplanes in the past, in case of the accident of Piper PA-46-350P occurred on January 3, 2011, other aircraft received emergency signals from the ELT for the aircraft. In case of the accident of Beechcraft A36 happened on July 28, 2011, the SAR satellite also received the distress signals from the ELT for the aircraft. As indicated in those accident cases, it is probable that if the ELT is installed in an appropriate manner at the time of the accident, it is useful to find the accident aircraft.

And as in described in 2.17.2.4, it is stated that several NTSB accident investigations have found ELTs detached from the airplane, which rendered them inoperable. And the NTSB pointed

out that in these cases, the inoperability of the ELTs delayed the aircraft's discovery and/or the rescue of occupants. The NTSB is concerned that these examples of ELT issues represent a more widespread problem that could endanger the lives of pilots and passengers who survive an aircraft accident, and requires that the ELT should be appropriately installed in the aircraft.

Based on the fact that as the auxiliary antenna for the ELT of the Aircraft was not appropriately installed, it was broken and inoperable at the time of the accident, and it could not be useful for the SAR operations, the Civil Aviation Bureau of the Minister of Land, Infrastructure, Transport and Tourism should provide small aircraft users with the information on appropriate installation and operation of the ELTs, if necessary.

3.13 Monitoring of Distress Frequencies by the SAR Aircraft

As described in 2.10.2.1, Annex 12 to the Convention on International Civil Aviation states that each SAR aircraft shall be equipped to be able to communicate on the aeronautical distress and on scene frequencies, and shall be equipped with a device for homing on distress frequencies.

As described in 2.10.1, the Police Helicopter stated that it was listening on one frequency for the Prefectural Police Headquarters and the other for the aircraft intercommunication, but did not listen on the distress frequency 121.5 MHz during its SAR operation after the accident of the Aircraft. However, in order to swiftly and precisely identifying the position of the accident aircraft and victims, it is absolutely necessary for the SAR aircraft not only to conduct the visual SAR operations, but also to listen on distress frequencies. It is required that the Civil Aviation Bureau of the MLIT should request relevant organizations to ensure that each SAR aircraft during SAR operation shall be able to precisely listen on the distress frequencies.

3.14 Instructions and Notification to Pilots Flying under VFR

3.14.1 Hazardousness of In-cloud Flight under VFR and Hazardousness of Flight in Icing Conditions

As described in 2.18.2, responding to the consecutive occurrences of the accidents of small airplanes (including rotorcraft) in in-cloud flight under VFR, in September, 2012, The Japan Transport Safety Board (JTSB) recommended the Minister, the Ministry of Land, Infrastructures, Transport and Tourism (MLIT) to address the measures to prevent the those accidents mentioned above. Upon the receipt of this recommendations, in December, 2013, the Japan Civil Aviation Bureau of the MLIT had an individual pilot be newly aware of the hazardousness of the in-cloud flight under VFR by using the opportunities of the Review System on Specific Pilot Competence and others. However, as shown in Table 6 in 2.18.1, after those recommendations issued, the following two similar accidents, other than the Aircraft's accident, happened because it was not able to maintain VMC under VFR: In March, 2014, a Cessna 172M Ram: JA3853: AA2015-4-4, a crash against a tower in Aichi Prefecture; In November, 2015, a Robinson R22Beta: JA7963: AA2017-5-1, a crash into the mountain slope in Annaka City, Gunma Prefecture. It is probable that in these accident cases, the pilots on their VFR flight could not make use of notified advices and contents which had been informed according to the recommendations.

Therefore, it is desirable that the Civil Aviation Bureau of the MLIT should promote more an understanding of the hazardousness of the in-cloud flight under VFR among pilots and consider stepping up the supervision, in order to make use of those prevailing understandings among pilots in actual aircraft operations.

Besides, as described in 3.7, in this accident, it is probable that the Aircraft's flight

performance was significantly deteriorated due to icing on the wings, as getting into in-cloud flight at an altitude with temperature at around 0°C.

It is required that the Civil Aviation Bureau of the MLIT should make it known to pilots that flight in icing conditions are extremely hazardous for the aircraft not certificated for flight in icing conditions and that those aircraft should definitely avoid flying in icing conditions.

3.14.2 Preparations and Precautions for Mountain Flying

As described in 2.16.1 “FAA Document: Tips on Mountain Flying”, it is stated that because of the more demanding nature of mountain flying, pilots should carefully consider their experience and background before beginning a flight into mountainous terrain (2.16.1.1) and that mountain flying presents demands on the airplane that may require more performance than light training aircraft have to offer. To react to strong winds and the up and down drafts they may cause will limit the ability of the airplane and the pilot (2.16.1.2). In addition, in 2.16.1.3, it recommends that in mountain flying, pilots should make sure that they have at least a 2,000 ft ceiling over the highest pass they will cross, and that they have about 24 km.

Besides, as described 2.19.4, the literature describes as follows:

On mountain flight, the altimeter indication errors may occur. In fact, some club members stated that the altimeter indication had temporarily failed in mountain flying. Therefore, it is necessary for pilots to visually keep sufficiently safe separation from the highest pass in mountain flying without depending only on the altimeter indicator.

It is desirable that the Civil Aviation Bureau of the MLIT should inform pilots of the precautions on mountain flying including those mentioned as above.

3.15 Fastening Seat Belt and Shoulder Harness

As described in 2.7.2, the fixed brackets for the right front seat and the aft seat were broken, which indicates the impact at the time of the accident would be significantly great. As described in 2.19.2, as seen in Photo 11, the Pilot did not fasten his shoulder harness, as described in 2.10.3, it is somewhat likely that at the time of the accident, the PIC and the Pilot fastened their waist seat belts but not their shoulder harnesses, and that the two passengers in the aft seat did not fasten their three point type seatbelts. Besides, as described in 2.8, it was reported that the PIC died instantly from a traumatic shock and the Pilot died immediately from a cerebral contusion.

As described in 2.19.5, the FAA encourages pilots for small airplanes to fasten their seat belts and shoulder harnesses in its home page. In principle, pilots are required to always fasten their seat belts and shoulder harnesses in flight except the case they need to remove it when such use interferes with cockpit duties.

To make sure that all persons on board fasten their seat belts and shoulder harnesses is essential to reduce the fatality risk at the time of the accident. The Civil Aviation Bureau of the MLIT should give pilots guidance in encouraging to fasten their seat belts and shoulder harnesses and should instruct them to ask their passengers to fasten their seat belts.

4 CONCLUSIONS

4.1 Summary of Analysis

- (1) The PIC and the Pilot held both valid airman competence certificates and valid aviation medical certificates. Besides, the Aircraft had valid airworthiness certificate and had been maintained and inspected as prescribed. (3.1, 3.2)⁴⁵
- (2) Based on the images taken by live cameras, probably, before its departure it could be anticipated that it would be difficult for the Aircraft to maintain VMC on this flight route and it is also probable that under the meteorological conditions, they should have considered the possibility of icing encounter, and the effects from turbulence in the vicinity of the mountaintop. (3.3)
- (3) It is somewhat likely that the Pilot wished to cross the mountains on homeward journey. It is also somewhat likely that the PIC would respect the Pilot's wishes to cross the mountains on homeward journey. (3.4.1)
- (4) It is also somewhat likely that assuming that the weather conditions and visibility in the east side beyond the mountains would be better than in the west side, the PIC thought that crossing the mountain would be possible, or he thought of flying close to the Tateyama Mountain Range for a while and trying to turn back depending on the situation. However, it is probable that the PIC should have decided to abandon the plan of crossing the Tateyama Mountain Range before their departure by forecasting and taking into consideration the meteorological conditions carefully, and placing a priority on safety. (3.4.2)
- (5) It is somewhat likely that it was the Pilot who flew the Aircraft on their departure, and he changed heading to south due to bad weather conditions and went over the Etchuzawanokoshi whose elevation is lower than surrounding mountains in order to cross the Tateyama Mountain Range and reach to the east side of it. (3.5.1)
- (6) The Aircraft crossed the Tateyama Mountain Range via the Etchuzawanokoshi, however, it turned back at once. It is probable that around the time of commencing to cross the mountains, the Aircraft got into in-cloud flight and icing conditions, tried to turn back, and substantially changed its route by turning left and right. It is also probable that it became difficult for the PIC and the Pilot to grasp its own position and surroundings by confirming visually the terrain, then, the Aircraft approached the vicinity of the mountaintop, the Aircraft crashed into it. It is somewhat likely that the Aircraft approached the vicinity of the mountaintop due to loss of visual contacts making the crash unavoidable, or due to failure to maintain minimum safe altitude from the flight performance deterioration by the Aircraft icing or stalled condition, or due to difficulty in flight controls because of encountering a severe turbulence. (3.5.2)
- (7) It is probable the Aircraft slid down the snowy slope after the crash and the engine was detached from the fuselage along the way. (3.5.3)
- (8) It is probable that the PIC and the Pilot should have decided to turn back without hesitation by placing a priority on safety before crossing the Tateyama Mountain Range, when they witnessed the conditions of fogs and clouds covering over the mountains. (3.6)
- (9) It is probable that the Aircraft is not certificated for flight under the icing conditions, but around the time of commencing to cross the Tateyama Mountain Range, the Aircraft got into in-cloud

⁴⁵ The numbers put at the end of each paragraph of this chapter shows the chapter and section numbers of the related descriptions in "Chapter 3 ANALYSIS".

flight, the ice accumulation was produced on the main and tail wings, which likely made an effect on the flight performance of the Aircraft. It is somewhat likely that the PIC and the Pilot recognized an icing encounter and tried to turn back .(3.7.1)

- (10) It is somewhat likely that the flight performance of the Aircraft was deteriorated due to the aircraft icing. It is also somewhat likely that the Aircraft stalled due to its encountering the turbulence in the vicinity of the mountaintop, or its turnings in order to avoid the crash into the mountaintop. (3.7.2)
- (11) As the westerly wind was forecast at about 30 kt during the time period when the accident occurred, and from its topographic point of view, the Tateyama Mountain Range was then the area in which turbulence tended to be generated when strong westerly winds blow, it was likely to generate turbulence easily around the Tateyama Mountain Range, it is probable that any aircraft should not have flown in the vicinity of its mountaintop. It is also somewhat likely that as getting into in-cloud flight with difficulty to grasp its own position, the Aircraft was forced to fly at non-safety altitude, unable to keep enough altitude away from the ridge, and crashed into the mountain after encountering severe turbulence. (3.8).
- (12) As the Tateyama Mountain Range was covered with clouds, the winds aloft were strong and a precaution against turbulence was required during the time period when the accident occurred, it is probable that the Aircraft should have flown at the altitude of the mountaintop elevation plus 2,000 ft or more. (3.9)
- (13) The investigation conducted after the accident revealed that no traces of faults were confirmed in the Aircraft control system and in each part of the engine. It is probable that the propeller had been rotating just before the Aircraft crashed into the snowy slope. (3.10)
- (14) The PIC should have sent the emergency code “7700” by transponder, notified relevant organizations and airplanes flying nearby the position of the Aircraft by using the distress frequency 121.5 MHz, and asked support from them. (3.11)
- (15) The ELT installed on the Aircraft was capable of functioning normally. However, it is probable that as the auxiliary antenna for the ELT was broken with a snap, the SAR satellite and the SAR aircraft were not able to receive the distress signal from the ELT on June 3, on the day of the accident. (3.12.1)
- (16) As the Company did not install and operate the ELT installed in the Aircraft according to the instructions in the ELT manufacturer’s manual, the auxiliary antenna for the ELT was broken with a snap by impact. (3.12.2)
- (17) It is required that the Civil Aviation Bureau of the MLIT should provide small aircraft users with the information on the appropriate installation and operation of the ELTs, if necessary. (3.12.3)
- (18) Annex 12 to the Convention on International Civil Aviation states that each SAR aircraft shall be equipped with a device capable of listening on the aeronautical distress and on scene frequencies in order to swiftly and precisely identifying the position of the accident aircraft and victims. It is required that the Civil Aviation Bureau of the MLIT should request relevant organizations to ensure that each SAR aircraft during SAR operation shall be able to precisely listen on the distress frequencies. (3.13)
- (19) It is desirable that the Civil Aviation Bureau of the MLIT should promote more an understanding of the hazardousness of the in-cloud flight under Visual Flight Routes among pilots and step up the supervision. In addition, the Civil Aviation Bureau of the MLIT should make it known to pilots that flight in icing conditions are extremely hazardous for the aircraft not certificated for

flight in icing conditions and that those aircraft should definitely avoid flying in icing conditions. (3.14.1).

- (20) On mountain flight, it is necessary for pilots to keep sufficiently safe separation from the highest pass. It is desirable that the Civil Aviation Bureau of the MLIT should inform pilots of the precautions on mountain flying including those mentioned as above. (3.14.2)
- (21) In principle, pilots should always fasten their seat belts and shoulder harness in flight except the case they need to remove it when such use interferes with cockpit duties. The Civil Aviation Bureau of the MLIT should give pilots guidance in encouraging to fasten their seat belts and shoulder harnesses and should instruct them to ask their passengers to fasten their seat belts. (3.15)

4.2 Probable Causes

It is probable that as the Aircraft got into clouds during VFR flight over the mountain region, it became difficult for the PIC and the Pilot to grasp its own position and surroundings by confirming visually the terrain, then, the Aircraft approached the vicinity of the mountaintop and crashed into it.

It is somewhat likely that the Aircraft approached the vicinity of the mountaintop and crashed into it due to loss of visual contacts making the crash unavoidable, or due to failure to maintain minimum safe altitude caused by the Aircraft icing or stalled condition, or due to encountering a severe turbulence. However, it could not be determined, since the PIC and all members on board were fatally injured.

Concerning the fact that the Aircraft came to fly into clouds, it is probable that the PIC and the Pilot had not confirmed thoroughly the weather forecast for the mountainous region before departure and they delayed in making a decision to turn back during flight.

5 SAFETY ACTIONS

5.1 Safety Actions Taken by the Company after the Accident

The Company has taken the following safety actions to prevent recurrence in light of the accident. (excerpts)

- (1) It tried to improve and raise awareness about safety among the all company staff by thoroughly complying with the relevant laws and regulations and implementing trainings and educations regarding safety issues.
- (2) It provided educations regarding the following issues: It should depart only when to be judged as possible to maintain VMC all through the flight route; It should decide well in advance on returning to the departed airport / on changing the flight route under unexpected unfavorable weather conditions.
- (3) It imposed operation limitations on flying over the mountain region like a voluntary restraint on this flight for a while, created the operating procedures of flying over the mountain region on which educations were based and provided with.
- (4) It decided to clarify the difference between flight training business (Aerial Work) and aircraft lease business regarding business activities and flight configurations as some of those were not

made clear.

- (5) It decided to set up a new flight club which the Company manages and controls by establishing club rules and its management regulations, setting an aircraft lease agreement, and reconsidering aircraft boarding contract.
- (6) It revised each flight operating procedure (sightseeing flights, aerial photo missions, flight training, and others).
- (7) It made it a rule to always carry a Company's portable phone on flight.
- (8) It considered where the ELTs to be installed in aircraft. In addition, it decided to provide procedures on how to operate the ELT in emergency situations and to have aircraft carry the procedures on board.
- (9) It installed a portable GPS in aircraft in order to obtain the information on aircraft including flight routes.

5.2 Safety Actions Taken by the Civil Aviation Bureau of the MLIT after the Accident

In order to address the recent occurrences of the accidents of small airplanes including this accident, the Civil Aviation Bureau of the MLIT took the following preventive measures. (excerpts)

From October to November 2017, the Civil Aviation Bureau of the MLIT held seminars regarding the safe flights, distributed leaflets for the purpose of making it known to pilots that the in-cloud flight under VFR is extremely hazardous, and reviewed its home page to make more accessible so that those leaflets can be easily confirmed through the home page. In addition, in April 2018, the Civil Aviation Bureau created a video to enlighten safety, which includes the CFIT⁴⁶ (Controlled Flight Into or Toward Terrain) prevention system, and widely shared the information on the importance such as calculation of weight & balance, confirmation of weather conditions, and compliance with flight manual.

5.3 Safety Actions Required to be Taken

5.3.1 Actions Required to be Taken by the Civil Aviation Bureau of the MLIT

- (1) As described in 3.7, it is somewhat likely that in this accident, as the Aircraft got into in-cloud flight at an altitude with temperature at around 0°C, the flight performance of the Aircraft was significantly deteriorated due to icing on the wings and others. It is required that the Civil Aviation Bureau of the MLIT should make it known to pilots that the icing conditions are extremely hazardous for the aircraft not certificated for flight in icing conditions and those aircraft should definitely avoid flying in icing conditions.
- (2) As described in 3.15, it is somewhat likely that at the time of the accident, the PIC and the Pilot fastened their waist seat belts but not their shoulder harnesses, and that the two passengers in the aft seat did not fasten the three point type seatbelts. To make sure that all crew members and passengers fasten their seat belts and shoulder harnesses is essential to reduce the fatality risk at the time of the accident. It is required that the Civil Aviation Bureau of the MLIT should encourage pilots for small airplanes to fasten their seat belts and shoulder harnesses and instruct them to ask their passengers to fasten their seat belts.
- (3) As described in 3.12.3, as the Company did not install the ELT in the Aircraft according to the

⁴⁶ CFIT (Controlled Flight Into or Toward Terrain) is a form of accidents, where a pilot without any problems flies an aircraft with valid airworthiness certification, and without his or her being aware of the possibility of a collision, the aircraft collides with the mountain, the terrain, the water surface or obstacles even when the functions of the aircraft are normal.

instructions in the ELT manufacturer's manual, its auxiliary antenna was broken with a snap, inoperable normally at the time of the accident, and not useful for the SAR operations. It is required that the Civil Aviation Bureau of the MLIT should provide small aircraft users with the information on the appropriate installation and operation of the ELTs.

- (4) As described in 3.13, it is probable that the Police Helicopter did not listen on the distress frequency 121.5 MHz during its SAR operation after the accident of the Aircraft. However, in order to swiftly and precisely identifying the position of the accident aircraft and victims, it is absolutely necessary for the SAR aircraft not only to conduct the visual SAR operations, but also to listen on distress frequencies. It is required that the Civil Aviation Bureau of the MLIT should request relevant organizations to ensure that each SAR aircraft during SAR operation shall be able to precisely listen on the distress frequencies.

6 RECOMMENDATIONS

6.1 Recommendations for the Minister of Land, Infrastructure, Transport and Tourism

In this accident, it is probable that as the Aircraft got into clouds during VFR flight over the mountain region, it became difficult for the Aircraft to grasp its own position and the surroundings by confirming visually the terrain, then, the Aircraft approached the vicinity of the mountaintop and crashed into it.

It is somewhat likely that the Aircraft approached the vicinity of the mountaintop and crashed into it due to loss of visual contacts making the crash unavoidable, or due to failure to maintain minimum safe altitude caused by the Aircraft icing or stalled condition, or due to encountering a severe turbulence. Concerning the fact that the Aircraft came to fly into clouds, it is probable that the PIC and the Pilot had not confirmed thoroughly the weather forecast for the mountainous region before departure and they delayed in making a decision to turn back during flight.

In view of the result of this accident investigation, the Japan Transport Safety Board recommends pursuant to the provision of Article 26 of the Act for Establishment of the Japan Transport Safety Board that the Minister of Land, Infrastructure, Transport and Tourism should take the following measures in order to prevent the aircraft accidents and reduce damage from those when they occur.

- (1) Make it known to pilots that the icing conditions are extremely hazardous for the aircraft not certificated for flight in icing conditions and those aircraft should definitely avoid flying in icing conditions.
- (2) Encourage pilots for small airplanes to fasten their seat belts and shoulder harnesses and instruct them to ask their passengers to fasten their seat belts.
- (3) Provide small aircraft users with the information on the appropriate installation and operation of the ELTs.
- (4) Request relevant organizations to ensure that each search and rescue (SAR) aircraft during SAR operation shall be able to precisely listen on the distress frequencies.

Appended Figure 1: Estimated Flight Route (1)

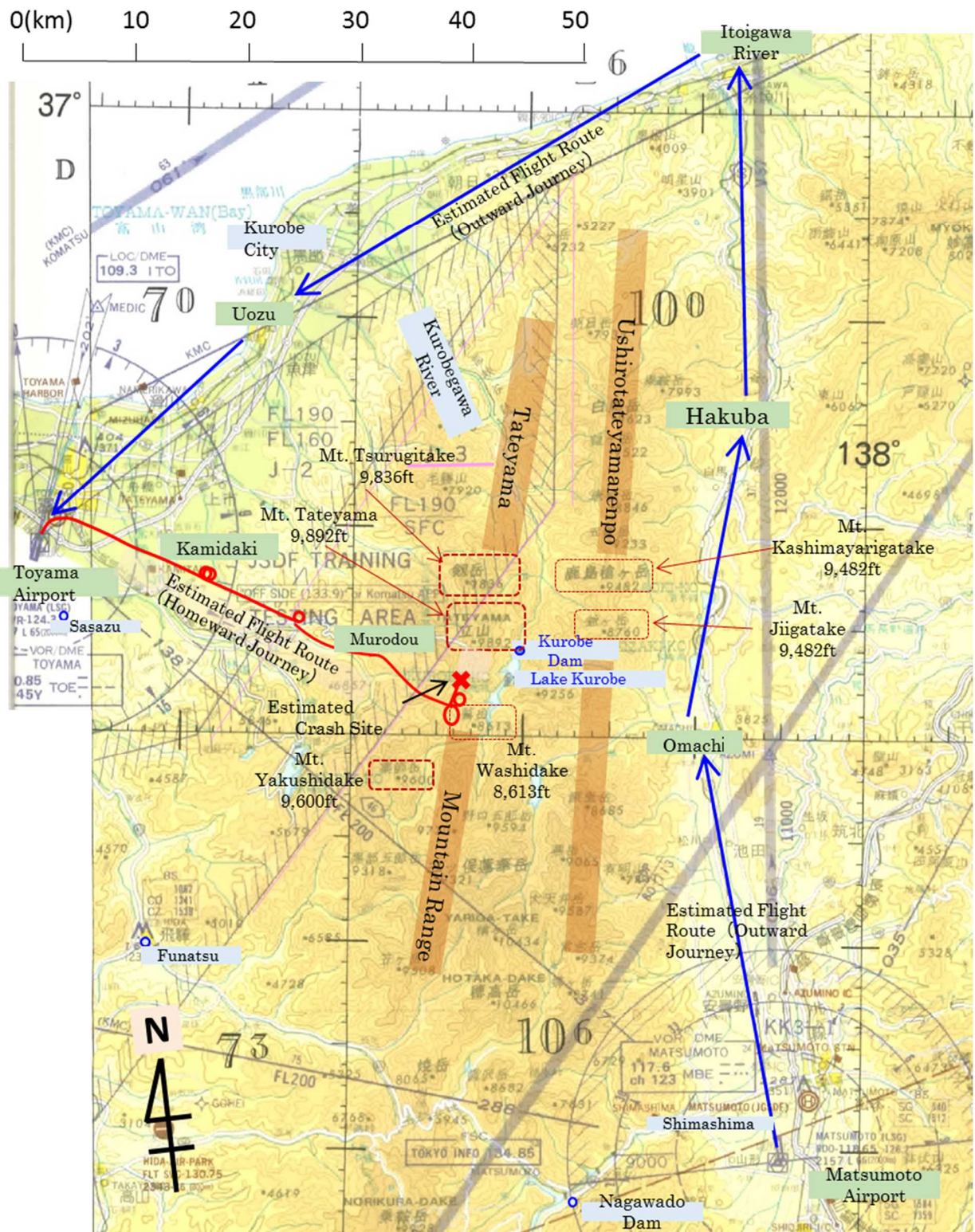

Division Aeronautical Map⁴⁷

⁴⁷ The division aeronautical map (published by the Japan Aircraft Pilot Association) is an airlines reference map that is useful for VFR flight. It shows the maximum terrain elevations (x 100 ft) within the ranges enclosed by latitude and longitude lines every 30 minutes as the reference values.

Appended Figure 2: Estimated Flight Route (2)

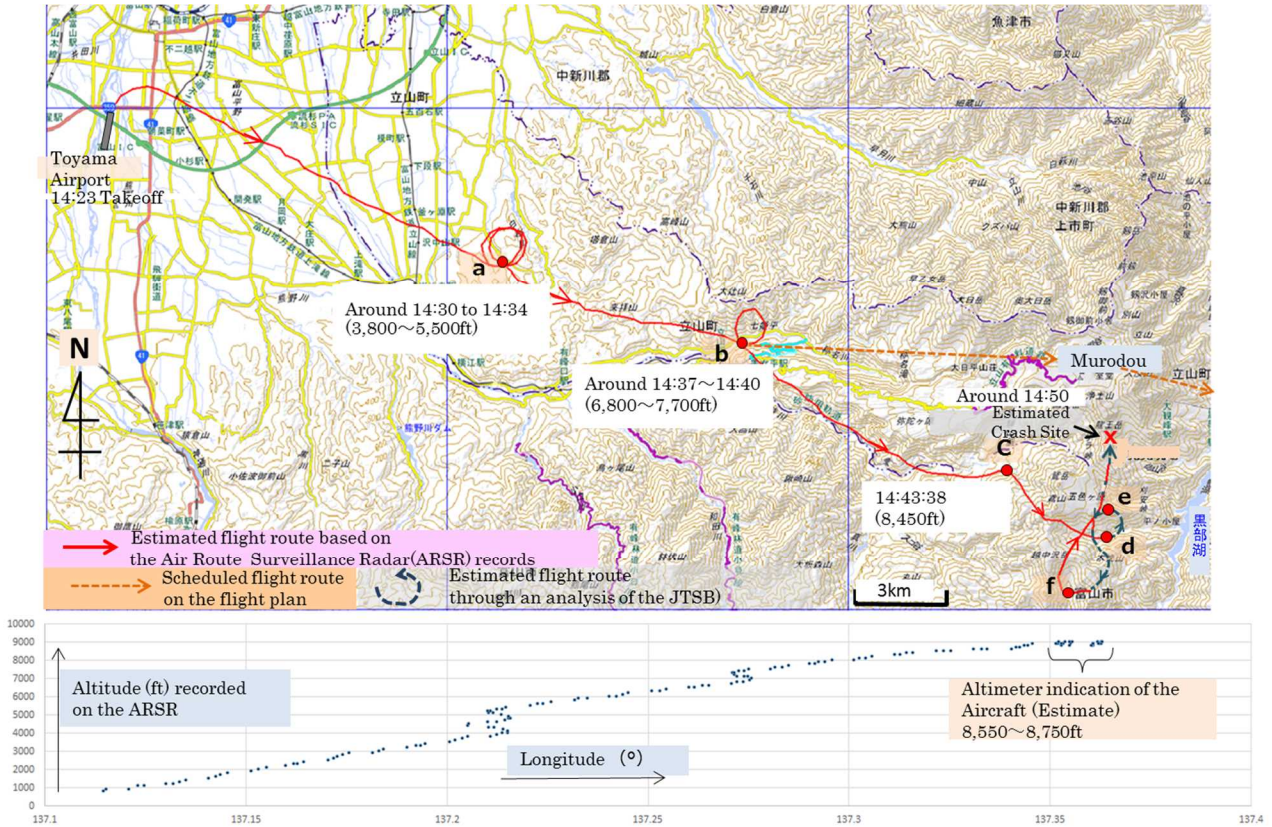

Based on Geospatial Information Authority of Japan map

Appended Figure 3: Estimated Flight Route (3)



Based on the MLIT Tateyama Caldera Sabo Museum

Appended Figure 4: Estimated Flight Route (4)

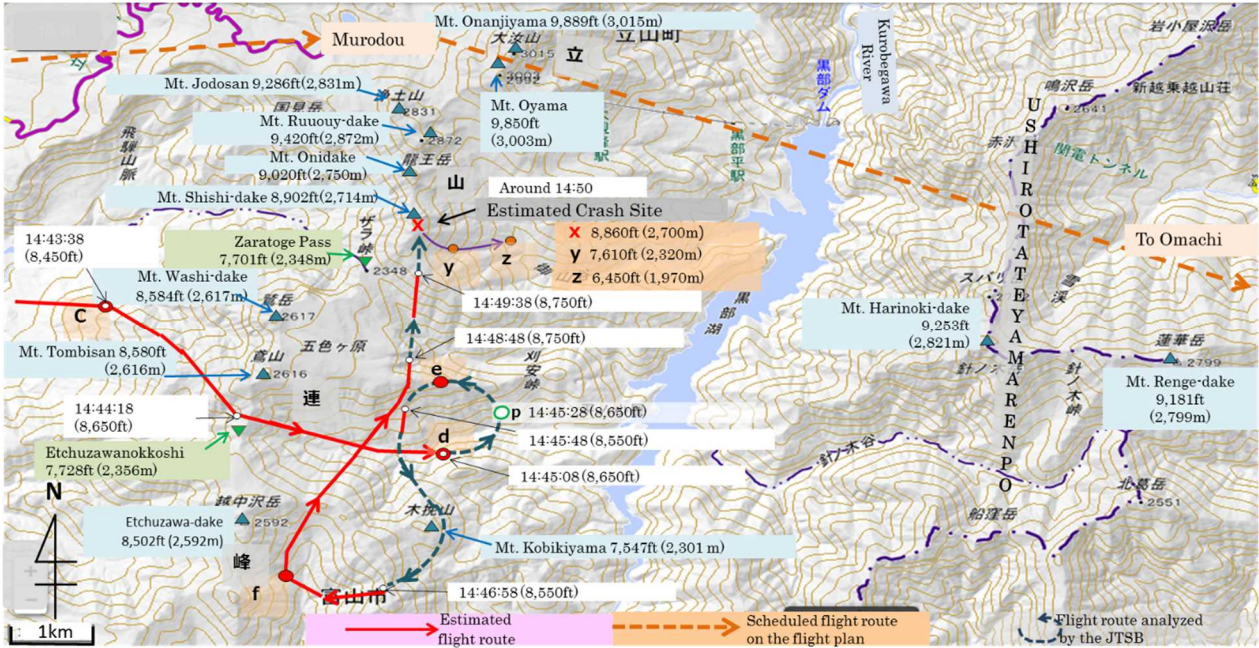

Based on Geospatial Information Authority of Japan map

Appended Figure 5: Accident Site

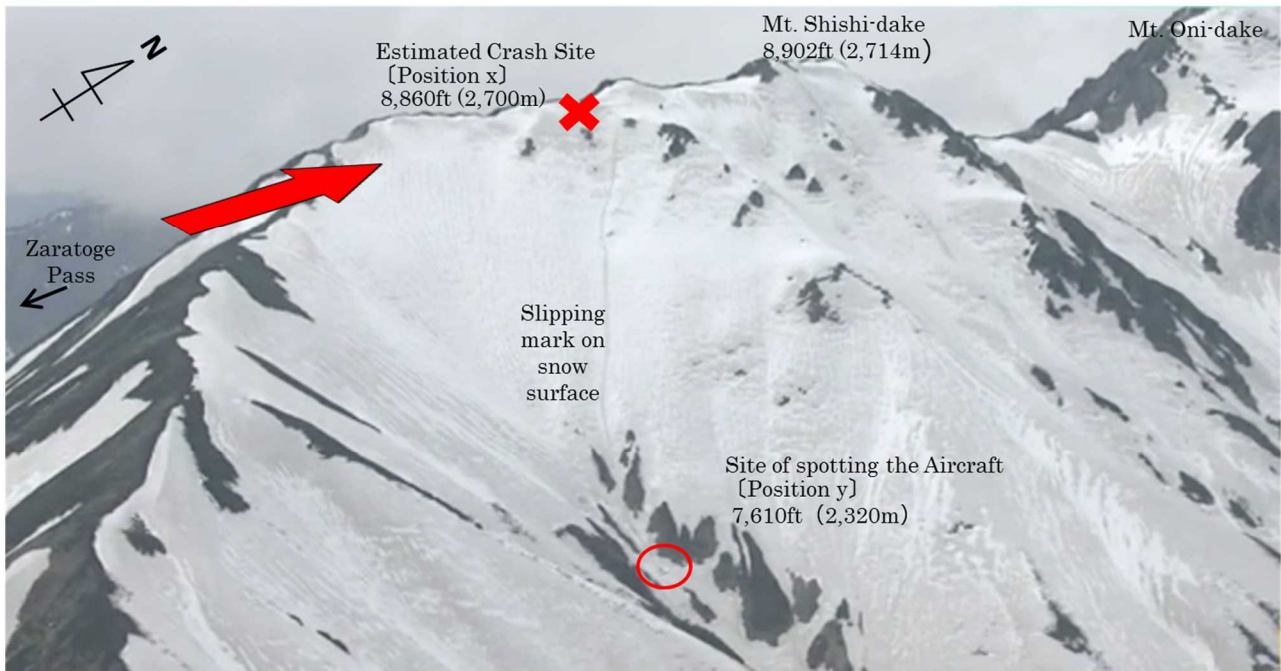

Appended Figure 6: Estimated Crash Site, Marks and Traces

(Based on the statements of the prefectural police mountain ranger and sketches)

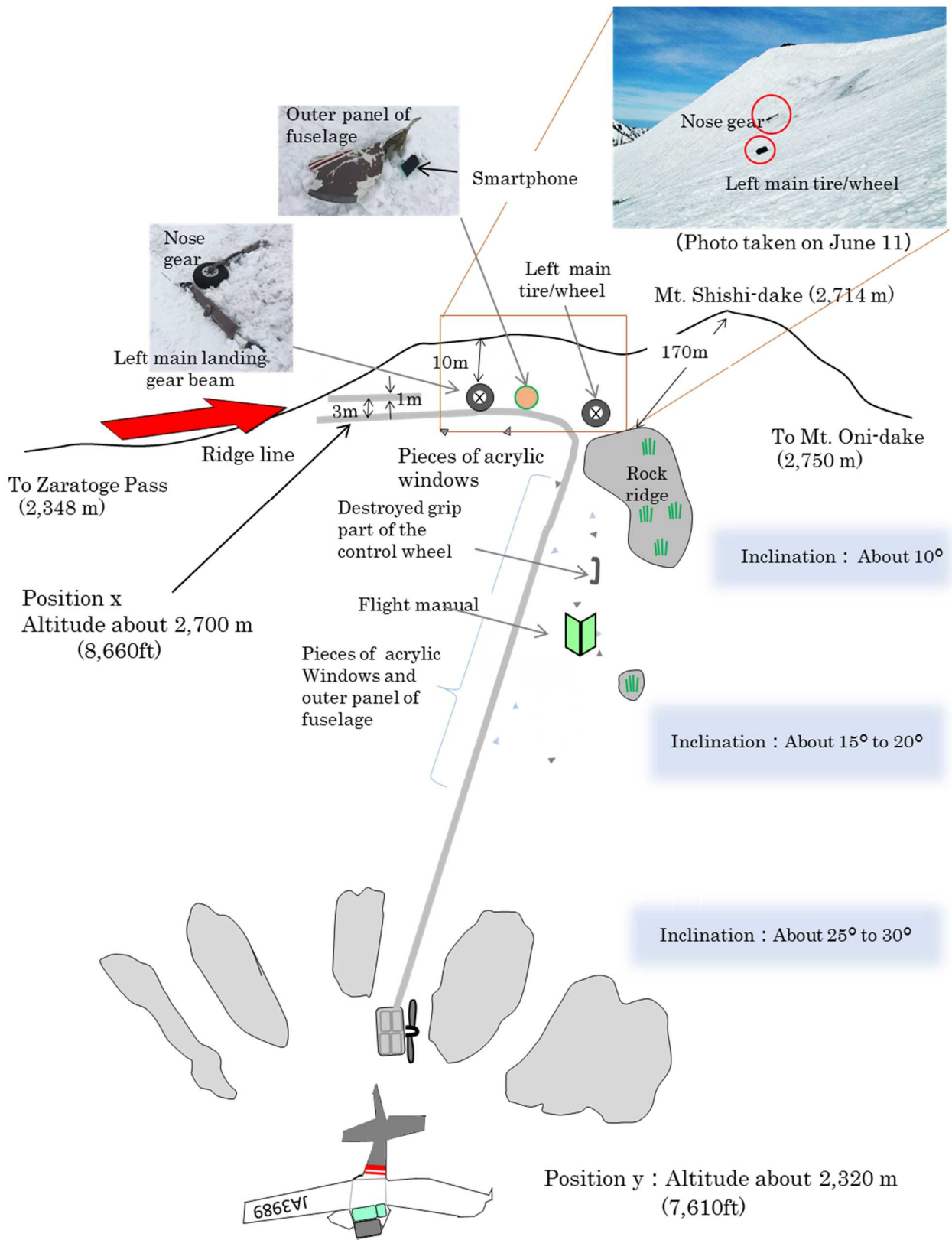

Appended Figure 7: The Site of Spotting the Aircraft

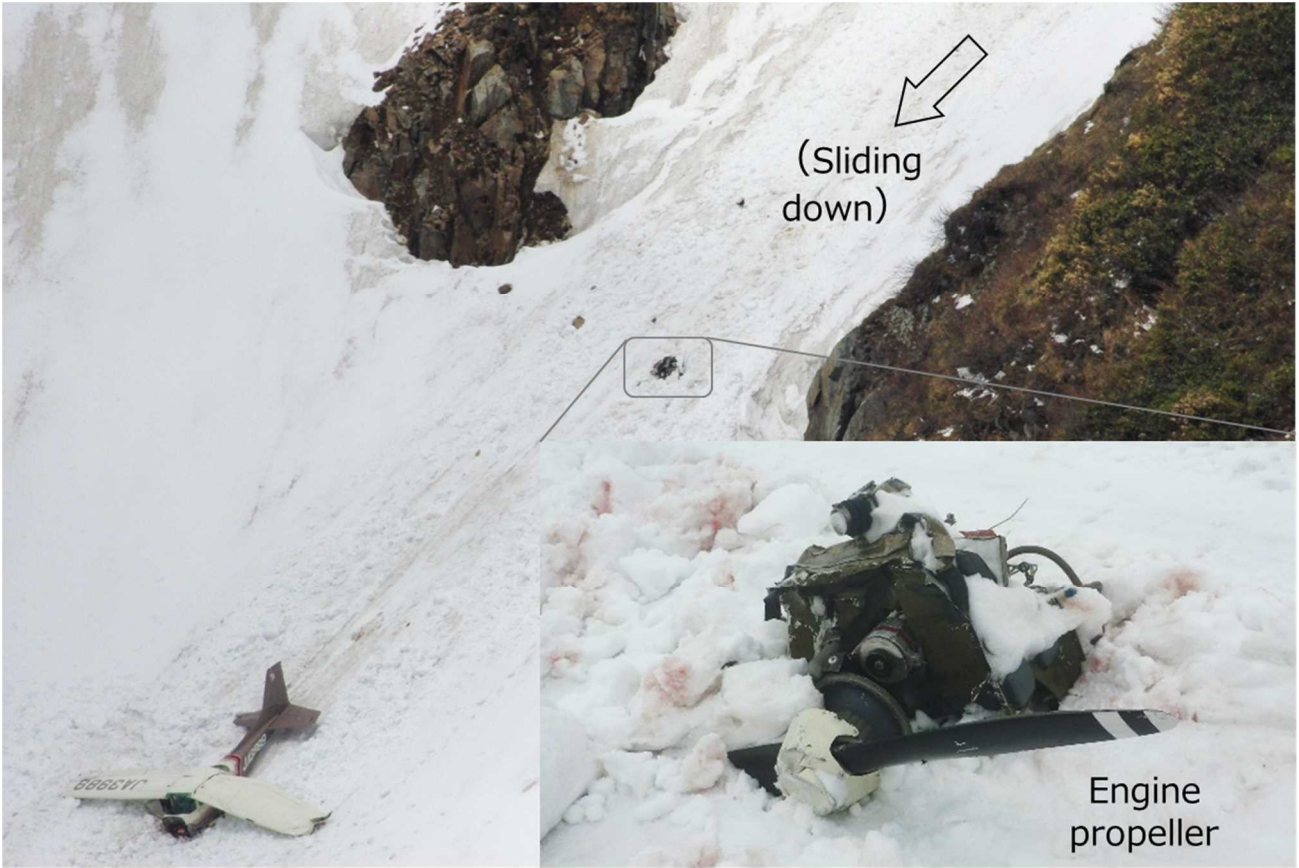

Appended Figure 8: The Aircraft Found at the Accident Site



Appended Figure 9: Meteorological Information (1)

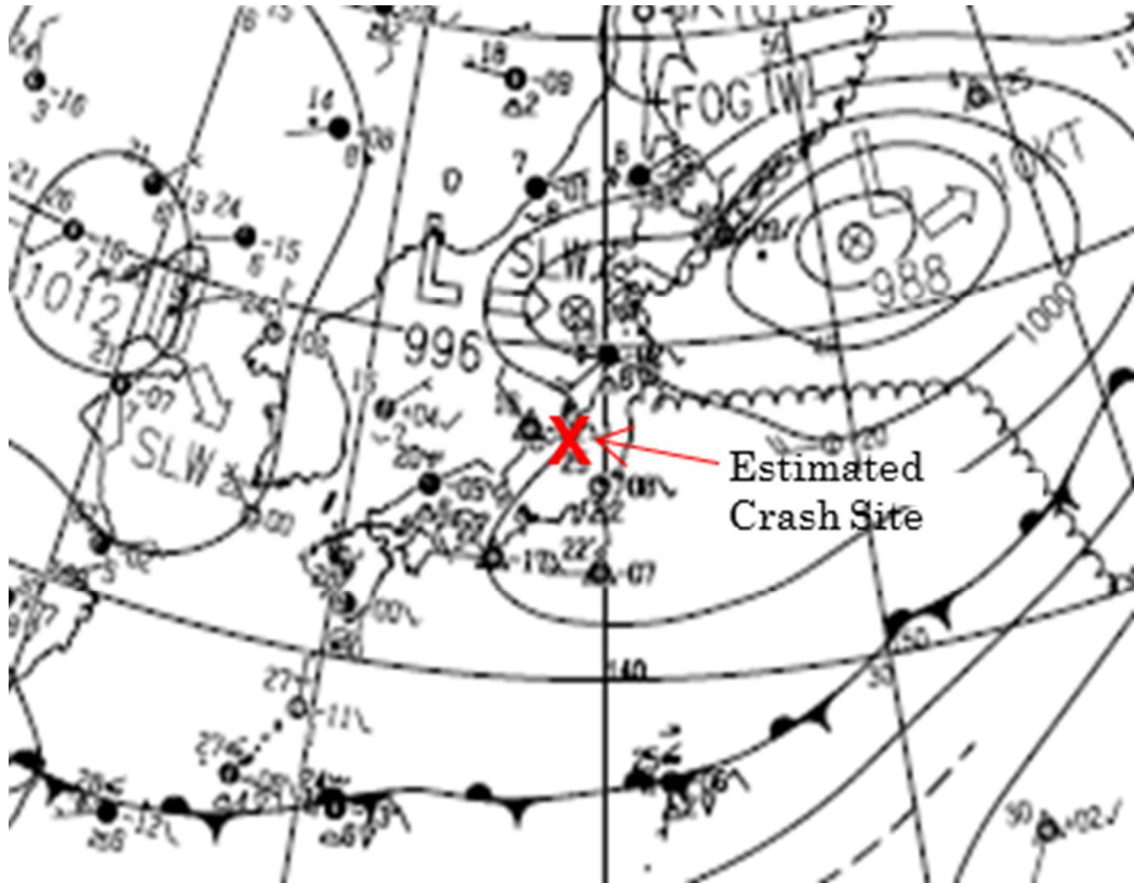

Surface Analysis Chart (15:00 June 3, 2017)

Appended Figure 10: Meteorological Information (2)

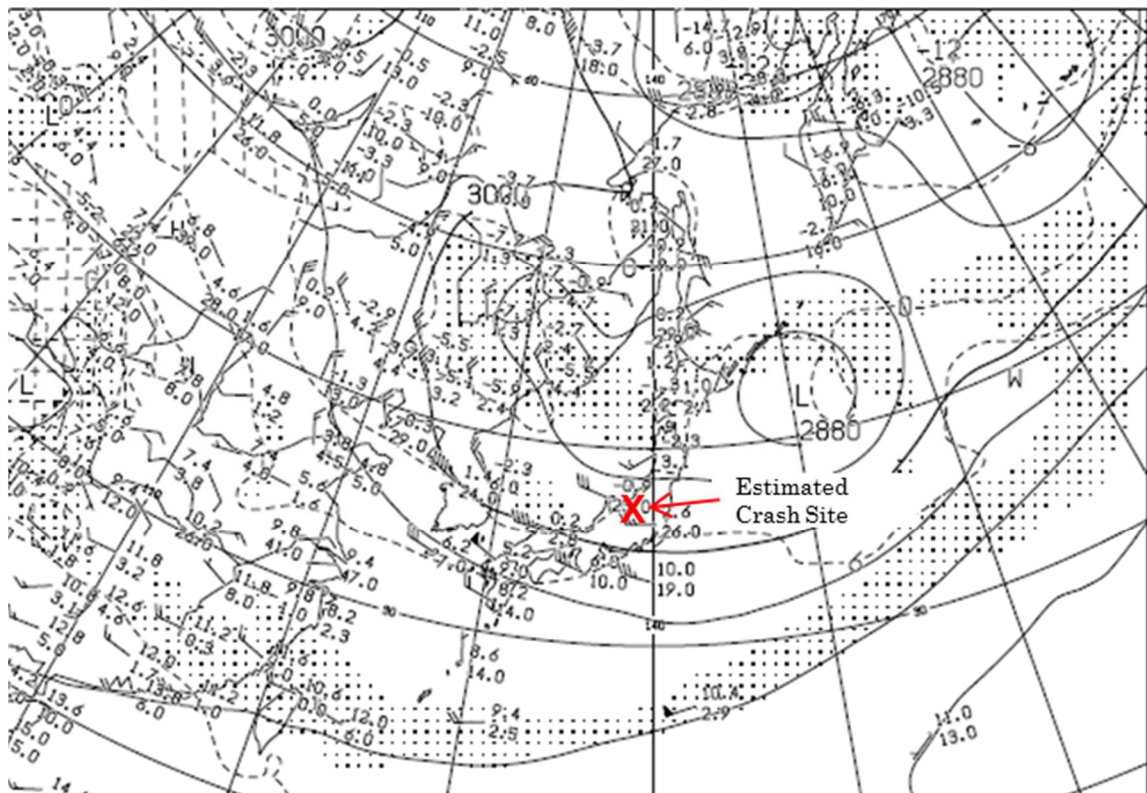

700hPa Upper Analysis Chart (09:00, June 3, 2017)

Appended Figure 11: Meteorological Information (3)

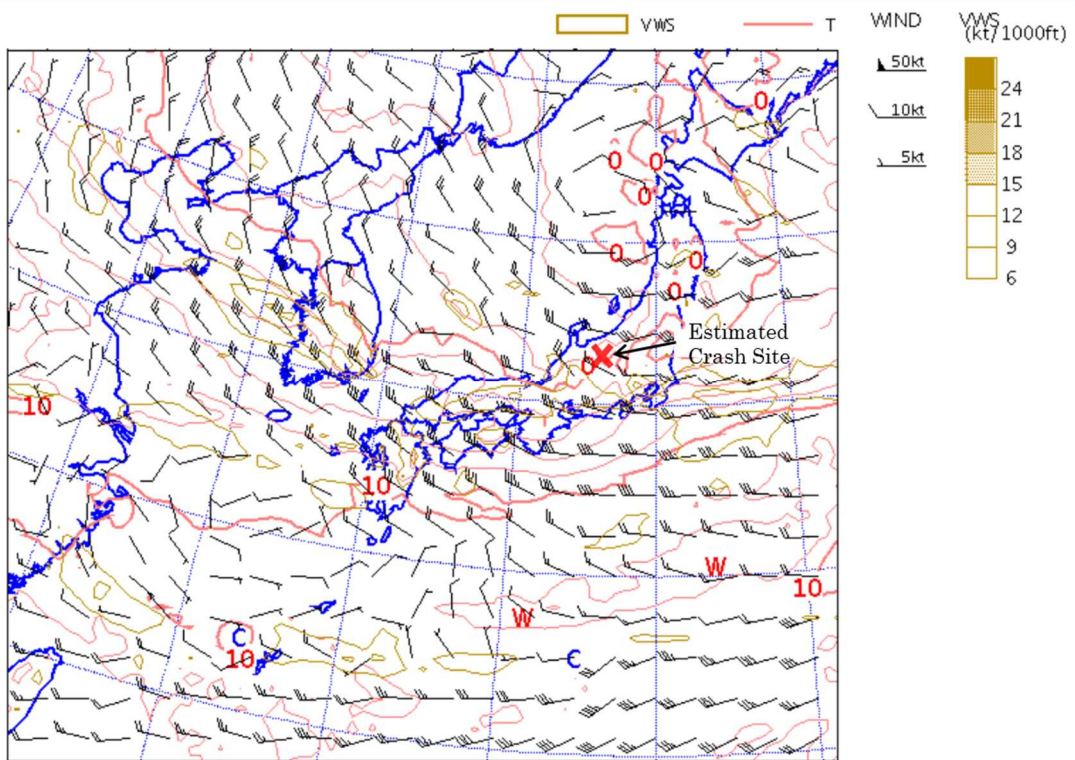

Appended Figure 12: Meteorological Information (4)

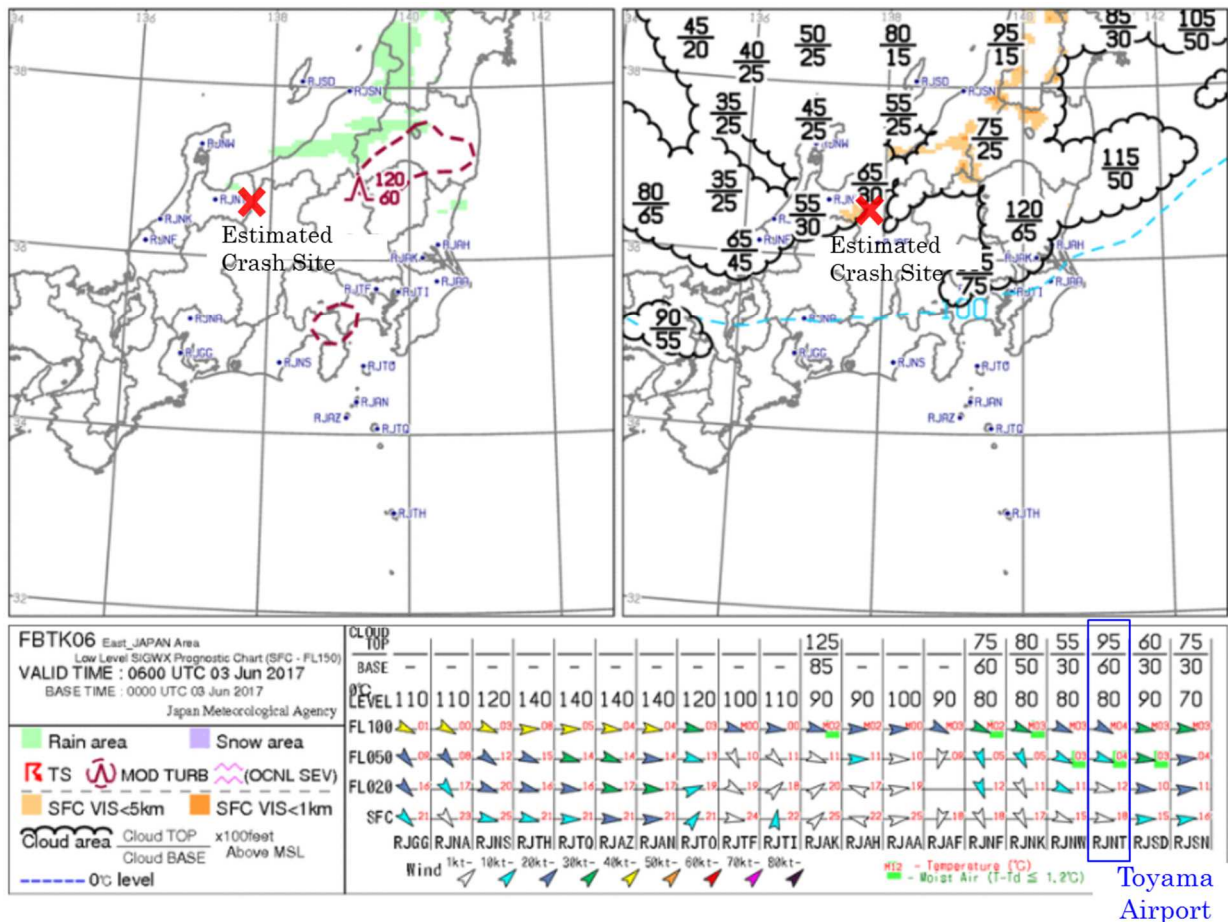

Significant Weather Prognostic Chart of Lower Layers (Valid until 15:00, June 3, 2017)

Appended Figure 13: Three Angle View of CESSNA 172P

Unit: m

