

AA2011-4

**AIRCRAFT ACCIDENT
INVESTIGATION REPORT**

ALL NIPPON HELICOPTER CO. LTD

J A 3 1 N H

April 22, 2011

Japan Transport Safety Board

The objective of the investigation conducted by the Japan Transport Safety Board in accordance with the Act for Establishment of the Japan Transport Safety Board and with Annex 13 to the Convention on International Civil Aviation is to determine the causes of an accident and damage incidental to such an accident, thereby preventing future accidents and reducing damage. It is not the purpose of the investigation to apportion blame or liability.

Norihiro Goto
Chairman,
Japan Transport Safety Board

Note:

This report is a translation of the Japanese original investigation report. The text in Japanese shall prevail in the interpretation of the report.

AIRCRAFT ACCIDENT INVESTIGATION REPORT

ALL NIPPON HELICOPTER CO., LTD.
EUROCOPTER EC135T2 (ROTORCRAFT), JA31NH
ON THE MARSH LOCATED ABOUT 800m SOUTHWEST OF
SHIZUOKA HELIPORT
AT SHIZUOKA CITY, SHIZUOKA PREFECTURE, JAPAN
AT ABOUT 10:53 JST, DECEMBER 9, 2007

March 29, 2011

Adopted by the Japan Transport Safety Board

Chairman	Norihiro Goto
Member	Shinsuke Endoh
Member	Toshiyuki Ishikawa
Member	Sadao Tamura
Member	Yuki Shuto
Member	Toshiaki Shinagawa

Table of Contents

1. PROCESS AND PROGRESS OF THE INVESTIGATION.....	1
1.1 Summary of the Accident.....	1
1.2 Outline of the Accident Investigation.....	1
1.2.1 Investigation Organization.....	1
1.2.2 Representative and advisers from Foreign Authorities.....	1
1.2.3 Implementation of the Investigation.....	1
1.2.4 Providing of Factual Information to Civil Aviation Bureau, Minister of Land, Infrastructure, Transport and Tourism, Japan.....	1
1.2.5 Interim Report.....	1
1.2.6 Comments from Parties Relevant to the Cause of the Accident.....	2
1.2.7 Comments from the Parties Participating States.....	2
2. FACTUAL INFORMATION.....	2
2.1 History of the Flight.....	2
2.1.1 History of the Flight Based on the Radar Track Records.....	2
2.1.2 Statement of the Mechanic on Board.....	2
2.1.3 Statements of Eyewitnesses.....	3
2.1.4 Statements of Persons Concerned.....	5
2.2 Injuries to Persons.....	5
2.3 Damage to the Aircraft.....	5
2.3.1 Extent of Damage.....	5
2.3.2 Damage to the Aircraft Components.....	5
2.4 Other Damage.....	5
2.5 Personnel Information.....	6
2.6 Aircraft Information.....	6
2.6.1 Aircraft.....	6
2.6.2 Engine.....	6
2.6.3 Weight and Balance.....	6
2.6.4 Fuel and Lubricating Oil.....	6
2.6.5 Reactive Torque of the Aircraft's MR.....	7
2.6.6 TR Control System.....	7
2.7 Meteorological Information.....	8
2.8 Aerodrome and Ground Facility Information.....	8
2.9 Information about Accident Site and Wreckage.....	8
2.9.1 Condition of Accident Site.....	8
2.9.2 Condition of Details of Damage to the Aircraft.....	8
2.10 Medical Information.....	9
2.11 Information about Search, Rescue, Evacuation and Others Related to Persons' Life and Death and Injuries.....	9
2.12 Tests and Researches for Fact Finding.....	10
2.12.1 Measurement of Positions of Marks Left on the Rod.....	10
2.12.2 Measurement of Displacement and Bending Load of Aft End of the Same Type of Rod.....	10
2.12.3 Opinions of National Institute for Materials Science about Rupture of the Rod and	

Stiffening of Ball Pivot.....	11
2.12.4 The Manufacturer’s Opinion on Fatigue Strength of the TR Control Rod.....	12
2.12.5 Opinion of Independent Administrative Institution Japan Aerospace Exploration Agency about the Rod’s Rupture.....	14
2.12.6 Information from Video Images Taken by Eyewitnesses.....	16
2.12.7 Tests on Flight Control Characteristics in Condition of Failed TR at the Time of Accident.....	17
2.12.8 Examination of Actuating Force of Input Lever of Fenestron Servo Actuator.....	19
2.13 Information about Maintenance at the Company.....	19
2.13.1 Statements of Persons Involved about TR Control’s Lack of Smooth Movement.....	19
2.13.2 Inspections of Ball Pivot and Threaded Area of the Rod.....	20
2.13.3 Locking Plate.....	21
2.13.4 Information about Ball Pivot and Threaded Area of the Same Type of Rod for Same Series Type of Aircraft.....	25
2.13.5 Base Where the Aircraft was Stationed.....	25
2.13.6 Maintenance Manual.....	25
2.14 Information about Flight Control by Captain.....	27
2.14.1 Statement of a Pilot Checker of the Company.....	27
2.14.2 Information about Landing Areas Near Place Where Malfunction Occurred.....	27
2.14.3 Flight Manual.....	28
3. ANALYSIS.....	29
3.1 Qualification of Personnel.....	29
3.2 Airworthiness Certificate of the Aircraft.....	29
3.3 Relations to Meteorological Condition.....	30
3.4 TR Failure.....	30
3.4.1 The Cause for Lack of Smoothness in the TR Control.....	30
3.4.2 The Cause for Loss of Control TR.....	30
3.4.3 TR Pitch Angle after Rupture of the Rod.....	31
3.4.4 Influence of Rupture of the Rod on Flight Control.....	32
3.5 Landing after Rupture of the Rod.....	32
3.5.1 Selection of Landing Area.....	32
3.5.2 Operations just before Crash.....	33
3.6 Factors for Survival at the Time of Crash.....	34
3.6.1 Crash Site.....	34
3.6.2 Fastening of Shoulder Harness.....	34
3.7 The Cause for Stiffening of Ball Pivot.....	34
3.8 Factors for Rupture of the Rod.....	34
3.9 The Threaded Area of the Rod.....	35
3.9.1 The Time When Looseness Occurred.....	35
3.9.2 The Time When a Crack Created.....	36
3.9.3 Probability of Finding a Crack.....	37
4. CONCLUSIONS.....	37
4.1 Findings.....	37
4.2 Probable Causes.....	39
5 OPINIONS.....	40

5.1	Implementation of Reliable Maintenance Work in Accordance with Manual.....	40
5.2	Appropriate Selection of Flight Training Syllabuses for Emergency Operations in Flight Training.....	40
5.3	Fastening of Shoulder Harness.....	41
6	ACTIONS TAKEN.....	41
6.1	Measures Implemented by Civil Aviation Bureau, Ministry of Land, Infrastructure, Transport and Tourism after Occurrence of the Accident.....	41
6.2	Measures Implemented by the Manufacturer after Occurrence of the Accident.....	41
6.3	Measures Implemented by the Company after Occurrence of the Accident.....	42
Figure 1	Estimated Flight Route.....	44
Figure 2	Three Angle View of Eurocopter EC135T2.....	45
Figure 3	TR Control System.....	46
Figure 4	Ruptured Portion and Movable Range of the Rod.....	47
Figure 5	Video Images Taken by Eyewitnesses.....	48
Photo 1	Accident Aircraft.....	49
Photo 2	Marks Left on the Rod.....	49
Photo 3	Fracture Surface in the Front Side of the Rod.....	50
Photo 4	Ball Pivot after Cut Off.....	50
Photo 5	Locking Plate.....	51

1. PROCESS AND PROGRESS OF THE INVESTIGATION

1.1 Summary of the Accident

On December 9 (Sunday), 2007, a Eurocopter EC135T2 (Rotorcraft), registered JA31NH, operated by All Nippon Helicopter Co., Ltd., took off from Tokyo Heliport in Tokyo for a ferry flight. While flying to Shizuoka Heliport, the aircraft crashed in Minami-Numagami, Aoi-Ku, Shizuoka City, Shizuoka Prefecture, at about 10:53 Japan Standard Time (JST: UTC+ 9hr, unless otherwise stated, all times are indicated in JST on a 24-hour clock).

There were two persons on board the aircraft, consisting of the captain and one mechanic on board, and the captain died and the mechanic on board was seriously injured.

The aircraft was destroyed, but there was no outbreak of fire.

1.2 Outline of the Accident Investigation

1.2.1 Investigation Organization

On December 9, 2007, the Aircraft and Railway Accident Investigation Commission (ARAIC) designated an investigator-in-charge and two other investigators to investigate this accident.

1.2.2 Representatives and Advisers from Foreign Authorities

An accredited representative and advisers of Germany, as the State of Design and Manufacture of the aircraft involved in the accident, and an accredited representative of France, as the State of Design and Manufacture of the engines involved in the accident, participated in the investigation.

1.2.3 Implementation of the Investigation

December 9 to 13, 2007	On-site investigation, Aircraft examination and Interviews
December 18 to 21, 2007	Aircraft examination and Interviews
January 11, 2008	Interviews
January 15 and 16, 2008	Aircraft examination
January 15 to April 30, 2008	Examination of Tail Rotor Control Rod and Ball Pivot
February 13, 2008	Aircraft examination and Interviews
February 25, 2008	Interviews
March 25 to 27, 2009	Examination of Tail Rotor Control Rod and Ball Pivot, and Examination of flight control characteristics
June 9 to December 7, 2009	Examination of Tail Rotor Control Rod and Ball Pivot
January 21, 2010	Aircraft examination
May 13, 2010	Aircraft examination
June 3 to July 16, 2010	Aircraft examination

1.2.4 Providing of Factual Information to Civil Aviation Bureau, Minister of Land, Infrastructure, Transport and Tourism, Japan

On December 10, 2007, ARAIC provided Civil Aviation Bureau, Minister of Land, Infrastructure, Transport and Tourism, Japan (JCAB) with the fact that the tail rotor control rod had ruptured, as information obtained through the fact-finding investigation.

1.2.5 Interim Report

On January 30, 2009, an interim report based on the results of the fact-finding investigation up to that date was submitted to the Minister of Land, Infrastructure, Transport and Tourism and made public.

1.2.6 Comments from Parties Relevant to the Cause of the Accident

Comments were invited from parties relevant to the cause of the accident. The comments of the captain were not invited, because he was dead.

1.2.7 Comments from the Participating States

Comments were invited from the participating States.

2. FACTUAL INFORMATION

2.1 History of the Flight

On December 9, 2007, a Eurocopter EC135T2, registered JA31NH (hereinafter referred to as “the Aircraft”), operated by All Nippon Helicopter Co., Ltd. (hereinafter referred to as “the Company”), took off from Tokyo Heliport in Tokyo for a ferry flight. It was flying to Shizuoka Heliport (hereinafter referred to as “the Heliport”) with the captain sitting in the right pilot seat and the mechanic on board in the forward left seat.

The outline of the flight plan submitted to the Osaka Airport Office was as follows:

Flight rules: Visual flight rules (VFR), Departure aerodrome: Tokyo Heliport, Estimated off-block time: 10:00, Cruising speed: 110 kt, Cruising altitude: VFR, Route: Odawara, Destination aerodrome: Shizuoka Heliport, Estimated flight time: 1 h 30 min, Purpose of flight: Ferry flight, Fuel load expressed in endurance: 2 h 20 min, Number of persons on board: 2

The history of the flight up to the time of the accident is summarized below, based on radar track records and the statements of the mechanic on board, eyewitnesses and persons relevant to the accident.

2.1.1 History of the Flight Based on the Radar Track Records

According to the radar track records, the Aircraft had been detected on radar monitor from Tokyo Heliport as of about 9:59 to a point about 5 km southwest of the southern end of Lake Ashinoko with an altitude of about 3,500 ft as of about 10:30.

During the flight, the Aircraft’s maximum altitude was about 4,000 ft and its speed was 120 to 130 kt in cruising and 100 to 110 kt in climbing.

2.1.2 Statement of the Mechanic on Board

I was sitting in the forward left seat with no control stick equipped. I was fastening the seat belt and the shoulder harness.

The Aircraft was flying to the Heliport as a refueling stop on its ferry flight for a maintenance service company (hereinafter referred to as “the Maintenance Service Company”) at Osaka International Airport. I was less experienced with a ferry flight, but the captain appeared to have experienced flying this flight route many times.

After passing over around Lake Ashinoko, the Aircraft suddenly started swinging. Later, the swing came to a halt, and when the Aircraft became stabilized with its nose deflected to the right and banked to the left, the captain said the rudder was not working. When I saw his feet, he was

fully depressing the left rudder pedal.

I telephoned the head office of our company to obtain an advice and reported that the rudder was not working. I also telephoned our base at the Heliport and made the same report. I heard that staff at the base would take steps for an emergency for us to ensure safety at the time of landing. As I reported these communications to the captain, he said we would make emergency landing and told me to be ready for such a situation. I thought that it would be better for us to land on a long runway or a dry riverbed rather than the Heliport and told him so. But the captain said he would try running landing or autorotation landing on the Heliport.

The captain had been controlling the Aircraft while fully depressing the left rudder pedal. But when I suggested to him that the rudder should be slightly returned to the neutral position for trouble shooting, he did so. However the Aircraft's attitude only worsened. Therefore, the captain continued the flight while fully depressing the rudder pedal after that. Judging from his face and voice, I felt he was calm. Although I had not been watching the speed indicator and the altimeter, I felt that the Aircraft was almost on a normal cruising with its speed and altimeter kept almost unchanged.

Because the captain was in control of all radio instruments, I have no memory about whether he communicated with the Fujigawa Gliding Field by radio.

I received a telephone call from the chief of maintenance and control division in our head office. I reported that the rudder pedal was not working so that we had difficulty controlling the Aircraft and that the captain was trying to land on the Heliport.

On our way to the Heliport, LOW FUEL 2 which is a low fuel quantity warning light of the supply tank for supplying fuel to No.2 engine illuminated. But this only meant a decline in the fuel amount in the supply tank on the right side, because the Aircraft was banking to the left and I reported this to the captain. Any other warning and caution lights did not turn on. The indications of the instruments were also normal.

Neither the captain nor I looked at the emergency operations procedures provided in the checklist and flight manual.

Later, the Heliport came into our sight. The chief of maintenance and control division in our head office telephoned us, but while I was talking with him, the captain began communicating with the Heliport. So I quickly hung up. Afterward, the Aircraft began to take a gradual turn to the right as its altitude or speed changed. I have no memory after that and I found myself in a hospital room when I recovered consciousness.

2.1.3 Statements of Eyewitnesses

(1) Eyewitness A

At the time of the accident, I was on duty for radio communication at Fujigawa Flight Service at the Fujigawa Gliding Field. At about 10:35, we received a message from the Aircraft that it was hoping to pass over along the coastline at an altitude of 1,000 ft and requested for information about aircraft flying in neighboring areas. So, I replied to the Aircraft that there were no aircraft flying nearby and there would be no problem with its passage, either. Later, I witnessed the Aircraft flying over the Fujigawa Gliding Field from the east to the west with a distance of about 1 to 2 nm from my place. The Aircraft's altitude was about 1,000 ft and its speed was about 100 kt, and it was a sideslip flight with its nose deflected.

(2) Eyewitness B

Because I happened to be there, I took a video picture of the Aircraft coming on flying from a place about 450 m north of the accident site. When I started shooting the video picture, the Aircraft was flying westward in the direction of southeast of my place, and it gradually turned itself straight to me. The Aircraft's speed was slow. The Aircraft decelerated, and judging from an apparent view from my place, the Aircraft looked as if it was stopping in the air at an altitude twice as high as the highest of the trees which I could see in the direction to the accident site. After that, the Aircraft started rotating to the right, and it began to descend while rotating. The Aircraft rapidly descended while circling about four times and its sight disappeared beyond the forest, and after that, I heard a crash sound.

I rushed to the direction where the Aircraft disappeared. When I arrived the accident site, I saw a woman seated in the Aircraft moving. The main rotor (hereinafter referred to as "MR") was not rotating, but I heard the sound of the engine running. I did not see any fire, but I thought it would be dangerous to get closer to the Aircraft. So I was watching the scene from the waterside of the marsh.

After a while, the woman was rescued by rescuers who arrived at the scene. The man whom I could not initially find on board was also rescued. But it appeared that the man was not moving at all.

(3) Eyewitness C (Fireman)

I work for the Shizuoka Air Rescue at the Heliport, about 700 m northeast of the accident site. I was on duty when the accident occurred. At about 10:50, we were notified from a company which operates our rescue helicopter that the Aircraft with its tail rotor (hereinafter referred to as "TR") failed would come to land. So I quickly went to the apron from our office and started taking a video picture of the situation. We received a request for making preparations with fire extinguishers and other items from the control office of the Heliport. So, we took measures for this request, too.

After a while, I saw the Aircraft approaching with a clearly unusual attitude while sideslipping with its nose deflected to the right. Shortly after I saw the Aircraft, it crashed while decelerating and rotating. I instructed our staff to call an ambulance and then, I went to the accident site by our agency's car with emergency equipment on board along with other members of our unit.

When we arrived at the waterside of the marsh at the accident site, we saw a person sitting in the left seat moving. The engine was running and the possibility of an explosion was considered. While we were wondering whether we should get closer to the scene, two mechanics who rushed from the base at the Heliport were getting into the marsh. So, we followed them. They stopped the engine.

The woman in the left seat had not lost consciousness. But when we talked to her, she did not answer. The woman appeared to have suffered no major injuries or bone fractures. The man in the pilot's seat was bending over and the cyclic stick was seen on his right side. We raised his body and kept his respiratory trachea open. I palpated him, but there was no pulse with him. I talked to him, but there was no answer. He was not breathing. The man was fastening the seat belt, but the shoulder harness was not with him.

In consideration of the condition of the two persons, we decided to wait for the arrival of stretchers. After the arrival of the stretchers, we carried the woman by fixing her on the stretcher. After that, we also carried the man by the same manner.

2.1.4 Statements of Persons Concerned

(1) Control Office Director at the Heliport

At about 10:45, we received a telephone message from the Company's office at the Heliport telling us that the Aircraft with a failed TR would come to land and asking us to understand for the possibility that its landing would be unstable compared to normal landing. In preparations for a possible emergency, we asked companies with personnel stationed at the Heliport to cooperate in firefighting and rescue operations. Preparations had been completed by about 10:49.

In response to the Aircraft's request to Shizuoka Flight Service for landing information, we reported information about the wind direction, the wind velocity and the atmospheric pressure to the Aircraft at 10:50. At 10:52, we received information from the Aircraft that it would approach to the direction of 06. There was nothing unusual in any of the communication, and we felt no indication that the speaker was upset. We did not receive any information about an emergency.

(2) Mechanic Who Made Preflight Check of the Aircraft

On the day of the accident, I began a preflight check of the Aircraft from about 5:00 in the morning. The check ended at about 5:30, and there was no abnormality. Because the Aircraft is stationed at a base at Niigata Airport, usually I have no opportunity to check it. From about 9:20, I started preparations for its ferry flight, and this was completed by about 9:40.

Around this time, the captain had arrived and began to check the exterior of the Aircraft. The captain confirmed the preflight checklist in which I had recorded. I told him that I found no particular problem with the Aircraft. At about 9:45, the captain and the mechanic on board got on the Aircraft, and it took off at about 10:00.

The captain had been working at the base at Tokyo Heliport since April 2007, but until then, he was at the Shizuoka Heliport base for several years. At that time, I flew with the captain several times, and the captain was very much familiar with the geographical features and the weather condition around the Heliport.

The accident occurred at about 10:53 at a place about 800 m southwest of the Heliport (Latitude 35°01'05" N, Longitude 138°24'15" E).

(See Figure 1 Estimated Flight Route, Figure 2 Three Angle View of Eurocopter EC135T2, Photo 1 Accident Aircraft)

2.2 Injuries to Persons

The captain was deceased and the mechanic on board sustained serious injuries.

2.3 Damage to the Aircraft

2.3.1 Extent of Damage

Destroyed

2.3.2 Damage to the Aircraft Components

Fuselage	Damaged
MR system	Damaged
TR system	Damaged

2.4 Other Damage

None

2.5 Personnel Information

Captain	Male, Age 57	
Commercial pilot certificate (Rotorcraft)		November 18, 1976
Type rating for Multi-turbine engine (land)		June 8, 1990
Class 1 aviation medical certificate		
Validity		December 24, 2007
Total flight time		5,765 h 56 min
Flight time in the last 30 days		3 h 15 min
Total flight time on the type of aircraft		391 h 40 min
Flight time in the last 30 days		0 h 00 min

2.6 Aircraft Information

2.6.1 Aircraft

Type	Eurocopter EC135T2
Serial number	0254
Date of manufacture	December 13, 2002
Certificate of airworthiness	Tou-18-510
Validity	January 8, 2008
Category of airworthiness	Rotorcraft Normal N or Special X
Total flight time	1,390 h 45 min
Flight time since last periodical check (800h/3Y check on March 9, 2006, performed at the Maintenance Service Company)	368 h 25 min
Flight time since last periodical check (400h and 12M check on December 26, 2006, performed at the Maintenance Service Company)	224 h 40 min
Flight time since last special check (check about TR control system, performed on October 20, 2007)	45 h 35 min

2.6.2 Engine

	No.1 Engine	No.2 Engine
Type	Turbomeca ARRIUS2B2	
Serial number	32019	32024
Date of Manufacture	August 28, 2002	September 12, 2002
Total used time	1,390 h 45 min	1,390 h 45 min

2.6.3 Weight and Balance

When the accident occurred, the Aircraft's weight is estimated to have been 2,521 kg and the center of gravity is estimated to have been 4,274 mm aft of the reference point and 54.5 mm right of the centerline, all of which are estimated to have been within the allowable range (maximum takeoff weight of 2,835 kg, the center of gravity range for the weight at the time on the accident: 4,210 to 4,425 mm aft of the reference point and 100 mm left to 100 mm right of the centerline).

2.6.4 Fuel and Lubricating Oil

Fuel for the Aircraft was Aviation JET A-1, and lubricating oil was Mobil Jet Oil II.

2.6.5 Reactive Torque of the Aircraft's MR

MR of the Aircraft, when seen from above, is rotating counterclockwise. So, in a power-on flight, the Aircraft's fuselage receives a reactive torque which deflects the nose to the right with clockwise rotations corresponding with the engine power at each time. At that time, TR generates a thrust which deflects the nose to the left to counter the reactive torque of MR.

The Aircraft is capable of generating a lift with which the vertical stabilizer deflects the nose to the left when a sufficient forward flying speed is maintained so that a power-on forward flight can be made even when TR has lost its thrust.

In the case of a power-off flight, namely an autorotation flight, an engine power will not be generated. So, there will be no reactive torque that deflects the nose to the right, but TR is capable of generating a thrust which deflects the nose to the right so that the nose may be steered to the right.

2.6.6 TR Control System

- (1) The ball bearing control is one push-pull cable and this transmits control movement of the rudder pedal to the yaw actuator placed inside Fenestron*¹.
- (2) The ball pivot is a spherical bearing installed to the front end of Fenestron. It supports the fitting of a hollow shaft at the aft end of the ball bearing control. The ball pivot freely slides and this enables angular movement of the TR control system backward from this.
- (3) The yaw actuator is a basic component of the Aircraft as a yaw control stability augmentation system which is operated continuously on electricity.
- (4) The TR control rod (hereinafter referred to as "the Rod") is placed in Fenestron. The male screw at the front end of the Rod has a left-handed thread and it is connected to the female screw at the aft end of the yaw actuator. Inserted between them is the locking plate with a larger diameter than that of both of them. The end sections where they are connected to each other are partially cut off so that the ends of the locking plate can be bent and fixed them. After the threads are tightened, the ends of the locking plate which sticks out over the diameter of both of them are bent at both cut-off places toward each side and fixed there so that the threads with the Rod will not loosen.
- (5) The Fenestron servo actuator moves the pitch angle of the TR blades by hydraulic pressure. It is installed to the section of TR hub. The aft end of the Rod is installed to the tip end of the input lever of the Fenestron servo actuator. The input lever juts out to the left against the Aircraft's longitudinal axis. When the input lever is pushed by the Rod and moved backward, the TR blades will have a low pitch angle.

As far as the pitch angle for the TR blades at the minimum pitch angle position is concerned, it has a reverse pitch because the TR blades also need to generate a thrust to the opposite direction as described in 2.6.5.

According to the manufacturer's manual, the movable range of the TR blade pitch angle is about -17 degrees to +35 degrees, with + indicating the side where the thrust is generated for deflecting the nose to the left.

*¹ "Fenestron" is the type of antitorque system that includes TR in the duct within the vertical stabilizer.

(See Figure 3 TR Control System, Figure 4 Ruptured Portion and Movable Range of the Rod, Photo 5 Locking Plate)

2.7 Meteorological Information

(1) Weather observations at the Heliport around the time of the accident were as follows:

9:00 Weather Fine ; Wind direction 160 degrees; Wind velocity 1 kt; Visibility Good

12:00 Weather Fine ; Wind direction 140 degrees; Wind velocity 3 kt; Visibility Good

(2) Aeronautical weather observations at Shizuhamu Airport, located about 14 nm southwest of the accident site, around the time of the accident were as follows:

11:00 Wind direction 270 degrees; Wind velocity 13 kt; Visibility More than 10 km

Cloud: Amount 1/8, Type Cumulus, Cloud base 3,000 ft

Temperature 13 °C; Dew point 2 °C ; Altimeter setting (QNH) 30.01 inHg

2.8 Aerodrome and Ground Facility Information

The Heliport is managed by Shizuoka City. Its runway is 35 m long and 30 m wide with a magnetic bearing of 050/230 degrees in the departure direction and a magnetic bearing of 060/ 240 degrees in the approach direction and a field elevation of 34 ft. As far as geographical features in surrounding areas are concerned, the Heliport is surrounded by hills to the north, the east and the west, and it is open only to the south. The runway and the apron, with elevated floor structures, are paved with asphalt and concrete. The apron is about 170 m long and about 50 m wide in a magnetic bearing of 040/ 220 degrees.

2.9 Information about Accident Site and Wreckage

2.9.1 Condition of Accident Site

The accident site was actually a marsh located about 800 m southwest of the Heliport. The Aircraft had stopped on the marsh, banking about 20 degrees to the right, with its nose inclined to a magnetic heading of about 050 degrees. Components and other items separated from the Aircraft were found widely scattered around the Aircraft.

(See Figure 1 Estimated Flight Route, Photo 1 Accident Aircraft)

2.9.2 Condition of Details of Damage to the Aircraft

(1) Fuselage, Tail Boom and Landing Gear

Regarding the fuselage, components forming the enclosure of the cabin, such as the ceiling, the windshield, doors, window and door frames, had completely fallen apart. The transmission deck was found banking about 30 degrees forward along with the main gear box. The floor structure was found separated into two parts forward and backward at a section near the aft end of the pilot's seat, while the skin of both sides of the fuselage had developed wrinkles vertically and in some parts, cracks.

The tail boom had been bent from the section where it is connected to the fuselage. The tail boom as a whole was found deflected about 30 degrees to the left. The lower part of Fenestron was damaged with cracks and holes found. But there was no other major damage in this area. Damage to the backward areas from the tail boom was less serious than that to the fuselage.

In the landing gear, cracks were found in the front side of the section where the right skid is connected to the front cross tube. But the cross tube had not been distorted, while

the skids had not been extended horizontally, either.

(2) MR System

The MR mast was found banking about 30 degrees forward along with the main gear box. The four MR blades were all found bent and broken at the root.

(3) TR System

The TR drive shaft was found separated from the main gear box. The flex couplings between each of the drive shafts which compose the TR drive shaft had been distorted.

The ball bearing control had been partially bent due to the distortion of the Aircraft following the crash. It could not travel in the situation where it had been installed to the Aircraft, but it could travel, when removed from the Aircraft, though it was stiff.

The sliding surface of the ball pivot had become stiff.

The Rod had ruptured in the threaded area, while the locking plate could not be found.

(See Figure 3 TR Control System)

(4) Engine Drive Shafts

The engine drive shafts on both sides were found separated from the main gear box.

(5) Fuel System

The main fuel tank had been broken and there was no fuel left in the tank.

Muddy water was found in the No. 1 and No. 2 chambers of the split supply tank and in the fuel filters for both engines.

(6) Seats

The pilot's seat on the right side was found entirely covered with mud, but the shoulder harness for the right seat had been wound by an inertia reel which was installed in the seat and stored. There was no mud in the wound part of the shoulder harness, indicating it had not been used at the time of the accident.

Mud was found in the whole of the front left seat with the shoulder harness for the seat pulled out.

2.10 Medical Information

(1) Captain

According to the autopsy records compiled by Shizuoka Prefecture Police, the cause for the captain's death was damage to the heart. It was assumed that the damage had been caused by a collision with a blunt object.

No alcoholic content was found in his blood. The result of a drug and poison test on the captain was negative.

(2) Mechanic on Board

The mechanic on board was seriously injured.

2.11 Information about Search, Rescue, Evacuation and Others Related to Persons' Life and Death and Injuries

According to eyewitness C, an official for fire fighting, and the Shizuoka City Fire Department Operations Section, information about rescue and other operations at the time of the accident were as follows:

10:53 Eyewitness C and others called Japanese emergency rescue telephone number (119) to the Shizuoka City Fire Department Operations Section.

10:58 Eyewitness C and others went into action from the Shizuoka Air Rescue at the

Heliport

- 11:02 Eyewitness C and others arrived at the accident site.
- 11:25 The mechanic on board was rescued from the accident site.
- 11:34 The captain was rescued from the accident site.
- 11:35 The mechanic on board was taken to hospital.
- 11:44 The captain was taken to hospital.

2.12 Tests and Researches for Fact Finding

2.12.1 Measurement of Positions of Marks Left on the Rod

In the lower aft part of the section where the Rod had ruptured, a metal underneath had been exposed with a black paint stripped in a rectangular area about 3 mm lengthwise and breadthwise, and the straight striated scratch mark about 3 mm wide and about 39 mm long were found further backward from there. The black paint for the Rod was found at the edge of the through hole of Fenestron which the Rod had contacted. When the Rod's position was adjusted in the longitudinal direction so that the section of the Rod where its metal underneath had been exposed matches the place where the stripped paint was found, the input lever of the Fenestron servo actuator came to a position with the minimum TR pitch angle.

The movable range of the tip end of the input lever of the Fenestron servo actuator was about 93 mm in the longitudinal direction on the whole stroke from the minimum pitch angle position to the maximum pitch angle position. When the minimum pitch angle position is assumed to be 0 % and the maximum pitch angle position 100 %, the most aft of the straight striated scratch mark found on the Rod was located at a place about 42 % longitudinal direction on the Rod from the minimum pitch angle position.

(See Figure 4 Ruptured Portion and Movable Range of the Rod, Photo 2 Marks Left on the Rod)

2.12.2 Measurement of Displacement and Bending Load of Aft End of the Same Type of Rod

The aft end of the Rod moves on an arc around the pivot of the input lever in accordance with the operation on the rudder pedal. The input lever moves on all the stroke of about 93 mm in the longitudinal direction. In that case, with the base point at the minimum pitch angle position, it moves in the lateral direction by a maximum about 23 mm to the left as it shifts toward the high pitch side. As described in 2.6.6 (2), the ball pivot freely slides, and it is so designed that bending load will not be applied on the Rod even if its aft end moves in the lateral direction.

The displacement in the lateral direction and the bending load of the aft end of the same type of rod were measured by installing the Aircraft's stiffened ball pivot on the same type of aircraft along with the same type of rod and the yaw actuator.

When the hydraulic pressure for the Fenestron servo actuator did not work, the tip end position of the input lever in the longitudinal direction was about 27 % from the minimum pitch angle position.

The position in the lateral direction of the aft end of the same type of rod installed to the stiff ball pivot was almost identical to the position of the tip end of the input lever in the lateral direction at the time when the hydraulic pressure does not work.

In this condition, a bending load necessary to change this position by a maximum displacement to the left in the horizontal direction was measured with a load meter attached to the

aft end of the same type of rod. The result showed that, the load increased, to a maximum about 5N, as the position shifted to the high pitch side. For comparison, the same measurement was made for a ball pivot which is not stiff. The load proved to be always about 1.5N regardless of the value of the pitch angle.

(See Figure 4 Ruptured Portion and Movable Range of the Rod)

2.12.3 Opinions of National Institute for Materials Science about Rupture of the Rod and Stiffening of Ball Pivot

A detailed examination of the Rod and the ball pivot removed from the Aircraft was committed to the National Institute for Material Science (hereinafter referred to as “NIMS”) in order to examine the causes for the rupture of the Rod and the stiffening of the ball pivot.

According to its report, the results of the examination about the rupture of the Rod and the stiffening of the ball pivot were as follows (Excerpt):

(1) The cause for the rupture of the Rod

- ① According to information from the manufacturer of the Aircraft, Eurocopter Deutschland GmbH (hereinafter referred to as “the Manufacturer”), the material used for the Rod was an aluminum alloy based on the DIN standard (Deutsche Industrie Normen) and it was recognized as sound from a material examination including a material component analysis, a hardness measurement and a metallographic observation.
- ② The ruptured portion of the Rod, when seen from outside, had been ruptured in the threaded area almost vertically against the direction of the axis of the Rod. The diameter of the ruptured portion is 8.9 mm. This is identical to information from the Manufacturer and it means that plastic deformation had little occurred in the ruptured portion.
- ③ A low magnification electron microscope observation of the fractured surface in the front side of the Rod showed radial markings as a sign of fatigue failure which was centered on the surface about 60 degrees inclined to the right from the lower part of the Rod. The starting point of the crack on the Rod is recognized to be traceable to this surface. The condition of the fracture surface from the starting point of the crack to about 5 mm ahead was rough, while the condition was relatively flat in the area further ahead where a deep crack was seen.
- ④ According to a high magnification electron microscope observation of the fracture surface in the front side of the Rod, the area from the starting point of the crack to about 5 mm ahead had generally shown a structure-dependent condition which can be seen in the initial stage of fatigue failure in areas where the crack grows at a relatively slow speed. Striation^{*2} was observed in some parts in this area. Striation was seen mainly in an area about 5 mm to about 8.6 mm, and in part of this area, dimple^{*3} was also seen. A small area from about 8.6 mm to 8.9 mm is a place where shear lip^{*4} occurs in the final stage of failure. Mainly dimple was observed in this area. As described above, signs of fatigue failure were seen in most parts of the fracture surface.
- ⑤ The intervals of striations correspond to the crack growth value on each load. Assuming

*2 “Striation” means a fine striped pattern which can be seen on the fracture surface as a sign of fatigue failure.

*3 “Dimple” means numerous small holes as traces of very fine hollows created when ductile failure occurs beyond tensile strength.

*4 “Shear lip” means an area which swells in the direction of tension, a sign observed in the final part of ductile failure.

that striations of 1 μ m have developed on the whole of the 8.9 mm area on the section of the Rod, the repetitive load frequency becomes 8,900 times. But the depth of the crack is about 5 mm smaller than at the starting point of the crack, while the crack growth speed in the structure-dependent area is slower than in the striation area. In consideration of these factors, the actual repetitive load frequency is higher than the 8,900 times. Moreover, considering the number of repetitive loads needed to generate the crack, the actual repetitive load frequency for the Rod is estimated to have increased to tens of thousands of times or more.

- ⑥ As for the cause for the rupture of the Rod, in view of the repetitive load frequency and the crack growth direction, it is considered probable that the Rod had developed fatigue failure following repetitive bending loads due to vibrations with vertical and horizontal factors mixed.

(See Photo 3 Fracture Surface in the Front Side of the Rod)

(2) The Cause for Stiffening of Ball Pivot

- ① When half of the stiff ball pivot was fixed with epoxy resin and the ball pivot was cut along the border of the fixed part and the remaining part without using water and oil, then the unfixed part was removed. As a result, the outer and inner rings were easily separated.
- ② In the outward appearance, corrosion was observed in the contact surface of the inner and outer rings. But there was no particular sign of corrosion on the outer circumferences of the rings.
- ③ A microscopic observation of the section of the contact surface of the rings fixed with epoxy resin showed no sign of corrosion with the inner ring as a copper-based alloy. Signs of corrosion were observed only with the outer ring as an iron-based alloy.
- ④ It is considered highly probable that the corrosion seen in the contact surface of the outer ring had been caused by galvanic corrosion or crevice corrosion.
- ⑤ Judging from the factors described above, it is considered highly probable that the stiffening of the ball pivot had occurred because red rust created with the corrosion of the contact surface of the outer ring caused volume expansion in the space between the two rings and this restricted the movement of the two rings.

(See Photo 4 Ball Pivot after Cut Off)

2.12.4 The Manufacturer's Opinion on Fatigue Strength of the TR Control Rod

The Manufacturer's opinion on the fatigue strength of the TR control rod is as follows (Summary):

(1) Analysis

- ① After this accident, a fatigue evaluation based on a vibration measurement test flight was made for the same type of rod with regard to the vibration of the yaw actuator.
 - a For the same type of rod installed on the same series type of aircraft, the loosening and damaged of the threaded area were found in May 2004. Therefore, an improved new type of rod with a function to prevent the threaded area from loosening was installed for production new aircraft as from February 2005.

The threaded area for the same type of rod is made of an aluminum-based alloy, and it has been fixed by bending the edges of the locking plate. But the threaded area of the new type of rod is made of steel and it is fixed by assembling retainer nuts with

radial grooves on the contact surface and a locking washer.

- b The natural frequency of the assembly of the new type of rod and the yaw actuator is, according to an analysis, 41 Hz when the ball pivot is in normal condition and 56 Hz when it is blocked/fixed.

A vibration measurement test flight was made by using the same series type of aircraft with the new type of rod installed in a situation where the ball pivot is in normal condition. The measurement with an accelerometer installed on the yaw actuator showed peak levels of acceleration at 26.3 Hz (four times of the MR revolutions), 52.6 Hz (eight times of the MR revolutions), 60 Hz (the TR revolutions) and 120 Hz (twice of the TR revolutions).

When the ball pivot is in normal condition, the natural frequency of the assembly of the new type of rod and the yaw actuator is distant from any of the peak airframe frequency values as mentioned above. But when the ball pivot is blocked/fixed, the natural frequency comes close to the airframe frequencies of 52.6 Hz and 60 Hz, and this increases the possibility of causing a resonance phenomenon that increases loads.

The mass of the new type of rod and the same type of rod is almost the same and their stiffness is also the same. Therefore, the both types of rod are equivalent to each other from a dynamics point of view.

- c The measured value as described in b leads to the maximum amplitude value. Assuming that the area from the position where the Rod is supported by the ball pivot to the aft end of the same type of rod is a beam and assuming that this maximum amplitude value is the beam's deflection at the threaded area, the bending load can be calculated as a concentrated load at this position. The stress of the threaded area of the same type of rod due to this bending load is smaller than the fatigue strength.

Therefore, the threaded area of the same type of rod has enough fatigue strength against the airframe vibrations when the ball pivot is in normal condition.

- ② After this accident, a fatigue analysis was made for the TR control rod while assuming the ball pivot is blocked/fixed.

The blocked/fixed ball pivot creates an additional bending load on the TR control rod.

- a. In order to measure the load of the horizontal movement of the assembly of the new type of rod and the yaw actuator, a test was made by using the same series type of aircraft with a blocked/fixed ball pivot installed.

The result was 9N when the aft end of the new type of rod was displaced by 20 mm to the lateral direction.

- b. The fatigue life for the TR control rod was sought by using the Manufacturer's Safe-Life Evaluation Method based on the measurement result as described in a as well as the S-N curve^{*5} for the material used for the threaded area of the TR control rod, on the assumption that the ball pivot is blocked/fixed, based on The Load Spectra for High Frequency Loads and Ground Air Ground Loads^{*6} and using the Log-normal

^{*5} "The S-N curve" is a graph with the Stress amplitude shown on the vertical line and the logarithm of the frequency number (N) on the horizontal line, which means the strength of endurance of the given material to cycled stress, specifically how many repetitions can cause a failure and how strong the stress should be when the material fails

^{*6} "The Load Spectra for High Frequency Loads and Ground Air Ground Loads" mean a series of data arranged to show the frequency number for each of the load amplitudes used in an analysis made by the manufacturer to draw the fatigue life.

Distribution*⁷ of the load spectra and the Minor's Rule*⁸

The fatigue life for the threaded area of the TR control rod, when the ball pivot is blocked/fixed, was estimated at 3,211 flight hours for the same type of rod. The value for the new type of rod was estimated at 53,696 flight hours or more in the same manner.

- ③ In consideration of the possibility of the load on the Rod increasing due to the resonance phenomenon with the airframe frequency as described in ①b, it is considered highly probable that the Rod can fail due to fatigue in a shorter period of time than the 3,211 flight hours.
- ④ According to an electron microscope observation of the fractured surface of the Rod, at the vicinity of the crack onset, the fractured morphology indicates a crack growth by fatigue corrosion. The process of damage changes to fatigue from a point about 0.7 mm from the crack onset. Fatigue striation could be found up to a distance of about 0.4 mm to the edge of the component opposite to the start of the crack. Only a very small area of about 0.4 mm width showed a ductile static failure. Oxygen and chlorine were detected in a material content analysis of the section in the area close to the crack initiation.

(2) Factors for the Rod's Rupture

An analysis of the Rod's fracture surface showed an indication of rupture due to metal fatigue. But when the ball pivot is not blocked/fixed, fatigue failure should not occur even if the Rod has the threaded area loosened, because it has enough fatigue strength against the applied loads.

If the ball pivot is blocked/fixed and when the pilot depresses the left rudder pedal to operate the rudder with the TR control on the high pitch angle side, the bending load on the Rod increases and when the yaw actuator operates in this condition, the bending load on the Rod increases further. In this condition, the resonance phenomenon due to the airframe vibration occurs on the Rod, applying repetitive bending loads exceeding the level of fatigue strength on the Rod. As a result, it is considered highly probable that the Rod had ruptured due to fatigue failure in a shorter period of time than the 3,211 flight hours.

2.12.5 Opinion of Independent Administrative Institution Japan Aerospace Exploration Agency about the Rod's Rupture

The examination report of NIMS as described in 2.12.3 and the materials obtained from the Manufacturer as described in 2.12.4 were presented to independent administrative institution Japan Aerospace Exploration Agency (hereinafter referred to as "JAXA") to ask for its opinion about the accuracy of the Manufacturer's data about the fatigue strength of the Rod in pursuit of the cause for the rupture of the Rod.

The opinion about the rupture of the Rod in the report is as follows (Summary):

The Manufacturer's analytical method is considered to be basically appropriate.

According to the Manufacturer's analysis, when the ball pivot is blocked/fixed and the threads are loose, the Rod has a fatigue life of 3,211 flight hours. This does not consider possible effects caused by the corrosion environment. When the possible effects of corrosion are considered, there is

*⁷ "The Log-normal Distribution" denotes a probability distribution about continuous variables that shows the distribution of data so designed that they come around the mean value. This can be seen on various occasions in statistics, natural sciences and social sciences

*⁸ "The Minor's Rule" denotes a linear cumulative damage rule and it is an analytical method which is widely used for fatigue strength analyses.

a possibility that the fatigue life becomes shorter. But because there is no material to be studied, any judgment cannot be made as to whether the fatigue life falls below 50 flight hours or not^{*9}.

(1) Cause for creation of the starting point of the crack

Observations of the fracture surface performed by NIMS and the Manufacturer found no signs of damage due to corrosion, such as corrosion pits. Therefore, it is considered probable that the influence of the corrosion environment was limited for the creation of damage at the starting point of the crack. It is considered somewhat likely that the damage at the starting point of the crack in the threaded area of the Rod had been caused by the loosening of the threads.

(2) From the creation of the starting point of a crack to the occurrence of a visible crack

The Manufacturer's observation of the fracture surface showed corrosion products in the neighborhood of the starting point of a crack. As far as the crack growth in the initial stage leading up to the appearance of a visible crack is concerned, it is considered somewhat likely that a crack had grown due to the corrosion environment at a low level of stress with which crack cannot usually grow or the crack growth had occurred faster than usual.

(3) From a visible crack to rupture

As described below from a point of view of fracture mechanics, it is considered probable that rupture can occur even with about 50 flight hours.

① Number of cycles

An observation of the fracture surface shows that the amplitude of the stress level which can cause the crack growth amounts to at least about 8,900 cycles. In consideration of the fact that the pilot's input in which the stress level becomes dominant is 25,000 times (500 times per 1 flight hour^{*10} multiplied by 50 flight hours), the 8,900 cycles mentioned above is a fully possible frequency number.

② Stress level

The condition of the fracture surface indicates that the estimated stress level amplitude is a level where the crack growth can fully occur, in consideration of the factors mentioned below, on the basis of the materials from the Manufacturer:

- a The concentration of stress due to the loosening of the threads of the Rod
- b An increase in the stress level due to the stiffening of the ball pivot
- c An increase in the stress level due to resonance with airframe vibrations

The Manufacturer's analysis shows that the stress level applied on the Rod is very small when the ball pivot is not blocked/fixed. If the Rod's threads are not loose, the concentration of stress does not occur. Therefore, it is considered probable that the stiffening of the ball pivot and the loosening of the threads of the Rod were main factors for the occurrence of the stress level that caused the rupture.

(4) Studies about the relationship between the timing for the loosening of the threads and the time when the special inspection was performed on the TR control system about 46 flight hours before the rupture of the Rod

As described in (3), there is a possibility that the time span in which a crack of visible size can reach the level of fracture is shorter than 50 flight hours. As described in (2), the

^{*9} "Whether the fatigue life falls below 50 flight hours or not" refers to the matter of whether the Rod's actual fatigue life was not longer than the 45 h 35 min of flight hours as the period of time from the special inspection performed on the TR control system on October 20, 2007 as described in 2.6.1 and 2.13.1(1) to the occurrence of the accident.

^{*10} "500 times per 1 flight hour" is a frequency drawn from the Manufacturer's analysis.

period of time from the creation of damage to the appearance of a visible crack cannot be judged for lack of pertinent materials. As described in (1), it is considered somewhat likely that the factor for the creation of the starting point of the crack had been the loosening of the threads, but the period of time up to the creation of the starting point of the crack and the appearance of the visible crack cannot be estimated. Therefore, it cannot be determined whether the loosening of the threads had occurred before the special inspection performed on the TR control system about 46 hours before the accident.

2.12.6 Information from Video Images Taken by Eyewitnesses

(1) Flight Condition of the Aircraft

Video image A shot by eyewitness B records the sound of collision at the time of the Aircraft's crash after it disappeared behind the trees. With an estimated sound speed of about 340 m/s, a calculation shows that it takes about 1.3 s for the sound of collision to reach the place where the eyewitness was taking the video pictures, which was about 450 m from the accident site. Therefore, a calculation can be made on how many seconds before the crash it was when the condition of the Aircraft had been shot in video image A. The heading of the Aircraft shot in video image A and other points can be determined from the direction of the picture shooting and the direction of the estimated flight route of the Aircraft. As to the condition of the Aircraft in video image B shot by eyewitness C, after considering the directions of the Aircraft from the place where video image B was shot and from the place where video image A was shot, comparison to the condition of the Aircraft in video image A shows about how many seconds before the crash it was when video image B had been taken. Thus, the following conclusion was drawn as to the specific points of time:

Video image A was taken from about 58 s before the crash, and the Aircraft was flying to the right in the picture with the right side of its front directed at video camera A. The Aircraft gradually changed its nose direction to the right in the picture and directed head-on to video camera A about 48 s before the crash. Later, the Aircraft directed its left side at video camera A. The Aircraft had a nose-down attitude in these sequences, but it later raised its nose up and again began to lower its nose down. About 11 s before the crash, its nose was greatly lowered down, but its forward speed did not increase and a rotation to the right gradually began. About 5 s before the crash, the Aircraft began to descend rapidly while rotating to the right.

The Aircraft's apparent altitude when it began a rapid descent about 5 s before the crash looks about 1.7 times as high as the height of the tree which appear in the picture. It rotated about 3.5 times from the start of rotation to the time when it disappeared behind the trees about 2 s before the crash.

Video image B was taken from about 21 s before the crash. At that time, the Aircraft was flying toward video camera B while sideslipping with its nose deflected to the right. With the direction and attitude unchanged, the Aircraft was approaching slowly. The Aircraft lowered its nose down greatly about 10 s before the crash, but its rotation to the right accelerated with the altitude kept unchanged. While keeping its altitude, the Aircraft almost reversed itself about 8.5 s before the crash, and as rotations accelerated, the picture came to an end about 4 s before the crash.

(See Figure 5 Video Images Taken by Eyewitnesses)

(2) Altitude before Crash

As described in (1), when the Aircraft's apparent altitude when it began a rapid descent about 5 s before the crash is assumed to be 1.7 times as high as the height of the tree seen in the picture, the Aircraft's altitude at that time is estimated at about 63 m, judging from a distance of about 450 m from the accident site to the place of the picture taken, a distance of about 95 m between the tree and the place of the picture taken and a height of about 7.8 m for the tree.

2.12.7 Tests on Flight Control Characteristics in Condition of Failed TR at the Time of Accident

To examine the flight control characteristics after the failure of TR at the time of the Aircraft's accident, a flight test with the same series type of aircraft and a test with a flight simulator were conducted while obtaining the Manufacturer's cooperation. The results of the tests were as follows.

(1) Flight test with the same series type of aircraft

A flight test was performed in situations in which there are no fears of damage to the airframe structure and danger of a crash.

- ① While presuming that after the failure of TR, the Aircraft's TR pitch angle remained at the minimum pitch angle, it was assumed that the condition of the TR's failure at the time of the accident can be simulated by depressing the right rudder pedal to the maximum position in the air. When a cruising flight was performed at about 80 to 100 kt, the nose deflected about 30 to 45 degrees to the right against the flight direction and the aircraft banked about 20 to 30 degrees to the left, but it was possible to control the Aircraft toward the target.
- ② Emergency operations training procedures established by the Manufacturer for the case of TR failure were confirmed.

When TR failed, the condition which occurred to the aircraft shall be analyzed at first while maintaining an enough altitude. As this, the speed shall be reduced gradually by a notch of 10 kt by taking the foot off the rudder pedal. When the speed has been reduced to 40 kt, a descent shall be started at a rate of 300 fpm and then, the behavior of the aircraft shall be confirmed. If the nose deflects to the left in this condition, running landing shall be selected while continuing a shallow approach. If the nose deflects to the right, the speed shall be increased again and autorotation landing shall be selected after approaching over the runway while maintaining the speed and the altitude at enough levels.

In this flight test, the aircraft descended and approached close to the surface of the landing area and then, the aircraft performed a power recovery after autorotation, or it took a go-around procedure before running landing.

- ③ According to the Manufacturer, the actual autorotation landing procedure is as follows: the actual autorotation landing procedure with the engine in-flight shut down has been only explained, and it has not been actually implemented.

In autorotation landing, in-flight engine shut down needs to be performed during an autorotation descent in order to enable an operation to reduce the descent rate by pulling up the collective lever for flaring near the surface of the landing area. But there is no need to perform in flight engine shut down at an early time. An operation to stop the engine shall be performed only after the pilot comes to firmly believe that the aircraft can land on the runway with a stable attitude, after starting autorotation at 70 kt over the

runway. A go-around shall be selected if it has been judged that landing on the runway may not be possible because the position for the start of autorotation was inappropriate.

- ④ For a go-around operation, the collective lever shall be gradually raised with maintaining 70 kt. In a go-around operation with the right rudder pedal depressed to the maximum position, like the situation in this flight test, when an operation for climb is performed by substantially increasing the engine power at a slow speed, the deflation of the nose to the right is feared to become greater, causing the aircraft to shift rotating. Therefore, attention must be paid for gradually increasing the engine power so that the aircraft will not shift rotating. Then, the aircraft needs to fully accelerate and climb while maintaining the speed.

But because the aircraft is sideslipping, the aircraft receives a strong air drag and therefore, a fairly strong engine power is needed to maintain the speed. As it is difficult to obtain an enough rate of climb, a wide air space was necessary for a go-around.

- (2) Test with a flight simulator for the same series type of aircraft

A test was conducted with a flight simulator in situations including a case where a flight test with an actual aircraft, such as the test as described in (1), cannot be made.

The simulation was performed in a circumstance with doldrums with an aircraft weight at the time of the accident, while assuming the condition of the failure of TR when the accident occurred by depressing the right rudder pedal to the maximum position.

- ① A cruising flight was possible in a range of about 40 to 120 kt. At about 120 kt, the nose of the aircraft deflected about 30 degrees to the right against the flight direction and the aircraft banked about 20 degrees to the left, and almost a maximum continuous power was needed. At less than 40 kt, the speed declined rapidly and the aircraft shifted rotating to the right.
- ② Autorotation landing on the runway was performed. When the aircraft shifted to autorotation, sideslipping came to a stop and it became easier to control the aircraft toward the target point.
- ③ A power-on running landing on the runway at a shallow approach at 70 kt was possible, but there was difficulty to perform a landing approach toward the runway while adjusting the speed, the power and the flight direction in the condition of sideslip.
- ④ An autorotation landing on the heliport could not be performed because an approach to a fixed point was necessary and this was difficult.
- ⑤ As described in 2.12.6 (2), the Aircraft's altitude about 5 s before the crash is estimated at about 63 m. Therefore, a go-around was performed at an altitude of about 200 ft in an approach at 40 kt. After the power was gradually increased and the speed was increased to about 70 kt, the aircraft barely climbed with a maximum continuous power. When the aircraft climbed while flying straight, the aircraft banked about 30 degrees to the left, and an enough rate of climb cannot be obtained due to an increase in air drag caused by sideslipping. The aircraft climbed while taking a moderate turn to the right by reducing the inclination to about 10 degrees, and this made it possible to obtain a rate of climb of about 200 fpm. Because it is difficult to draw an intended flight route, and a wide air space was necessary.
- ⑥ A recovery operation after the shift of rotation was tested. When the speed was reduced from 40 kt, the airspeed indicator immediately declined to just above 0 and the aircraft shifted gradually rotating to the right. The altitude needed to increase the speed and

stop the rotation with lowering a collective lever down and pushing cyclic stick forward to lower the nose was about 300 ft after a rotation of about 30 degrees, about 500 ft after a rotation of about 40 degrees and about 1,500 ft after a rotation of about 90 degrees.

2.12.8 Examination of Actuating Force of Input Lever of Fenestron Servo Actuator

An examination was performed at the Manufacturer for the actuating force of the input lever of the Fenestron servo actuator by using a mock-up model for maintenance training for the same series type of aircraft.

When the movement of the input lever of the Fenestron servo actuator was confirmed by hand, while the hydraulic pressure system for the mock-up model for maintenance training was operated, the input lever moved only with an extremely small force applied. If it starts moving, the lever continued to move even in a hands-off condition.

2.13 Information about Maintenance at the Company

2.13.1 Statements of Persons Involved about TR Control's Lack of Smooth Movement

(1) Mechanic at the base where the Aircraft was stationed

I am routinely in charge of the maintenance of the Aircraft at the base where it has been stationed at Niigata Airport. I have heard from several pilots who boarded the Aircraft on a few occasions that they momentarily felt something unusual when they operated the rudder pedals just after the start of flight. The first information in my memories is related to the pilot who boarded the Aircraft in July 2007, who told me that he felt something unusual only briefly and that he did not know specifically what the symptom was. I received a report from captain A on August 18 of the same year that he felt heaviness in the operation of the rudder pedals compared to other aircraft. After that, I also often received reports from other pilots. I checked the condition of the Aircraft on each occasion, but the cause for the problem could not be identified because such a phenomenon could not be reappeared on the ground.

On October 18 of the same year, I received a report from captain B who always boards the Aircraft at the base where it is stationed that when he operated the rudder in his flight while fully depressing the left rudder pedal, the pedal lacked smoothness and scratched as its condition was unusual. To check this problem, I performed the movement check of the rudder pedal on the ground while running the engine, but the condition could not be reappeared. From October 19 to 20, I performed the check to confirm the actuating force of the input lever by installing a hydro device^{*11} on the Aircraft and removing the aft end of the Rod connected to the tip end of the input lever of the Fenestron servo actuator, but I found no problem. In this condition, I also performed the movement check of the rudder pedal and I felt a movement which is not smooth, though it was not something like an abnormal scratch. Therefore, I suspected that something unusual occurred with the ball bearing control cable and I decided to replace it with a new one. But because mechanics at the base where the Aircraft was stationed had no experience with such replacement work and because an airworthiness inspection was coming soon, we decided to commit the Maintenance Service Company in charge of maintenance before airworthiness inspection to change it.

^{*11} "Hydro Device" means equipment with a motor which electrically operates the axis of the aircraft's hydraulic pump to check the hydraulic pressure system in a condition where the aircraft's engine is stopped.

The aft end of the Rod and the tip end of the input lever of the Fenestron servo actuator had been disconnected for inspection. When I tried to reconnect the aft end of the Rod and the tip end of the input lever again, the aft end of the Rod easily turned around only with a slight finger touch and there was looseness in the joint of the Rod and the yaw actuator. So, I manually turned the Rod to the right to tighten the joint. Eventually, I might have reconnected the parts in a condition where they are turned to the right compared with the condition before they were disconnected. Because the locking plate is installed in this joint, it is generally believed that the Rod cannot be turned around easily. But I could turn around the Rod manually at that time. The joint cannot be seen from outside because it is covered with the Fenestron.

(2) Captain A

I felt something unusual when I operated the rudder pedal in my flight on August 18, 2007. When I depressed the rudder pedal, I felt it was slightly heavy compared with other aircraft. The symptom was nothing more than lack of smoothness when compared with other aircraft. I felt the problem when I operated the rudder while fully depressing the left rudder pedal during a climb after take-off, but I did not feel such problems on other occasions.

I boarded the Aircraft a few times after that. I sometimes felt similar problems, but sometimes not.

(3) Captain B

I have routinely boarded the Aircraft at the base where it is stationed at Niigata Airport. From around June 2007, I was feeling a symptom that vibrations can be directly sensed on the rudder pedal, a condition which can be felt on aircraft which have no hydraulic pressure system installed for the rudders. But I did not feel this symptom was abnormal, because I did not know about the condition by boarding other aircraft for comparison. When I heard from captain A about his talk on August 18, I came to realize for the first time that this symptom is abnormal.

It was on October 18 when I understood that this is clearly a failure. On the day, when I depressed the left rudder pedal after ending a right turn after take-off, I felt an unusual scratch on the pedal. When I confirmed the movement of the rudder pedal by fully depressing it in the air, an unusual scratch was felt with the pedal, but a condition in which the pedal is not stiff reappeared.

This condition was not reappeared on the ground. It did not reappear in later flights, either.

2.13.2 Inspections of Ball Pivot and Threaded Area of the Rod

(1) Periodical inspection performed on March 9, 2006

According to 2.13.6 (1), (2) and (6) to be described later, an English written maintenance manual issued by the Manufacturer provides that a periodical inspection of the TR control, including an inspection of the ball pivot, must be performed every 800 flight hours or every three years, whichever occurs first. As described in 2.6.1, the previous periodical inspection was performed by the Maintenance Service Company on March 9, 2006, 368 h and 25 min in flight before the occurrence of the accident. According to the inspection records, the inspection of the ball pivot was actually performed and no abnormality was found with the ball pivot.

(2) Troubleshooting of the TR control system performed on October 20, 2007

The troubleshooting for the TR control system as described in 2.13.1 (1) was performed on October 20, 2007, 45 h and 35 min in flight before the occurrence of the accident, as described in 2.6.1. But it was not performed in accordance with the trouble shooting procedures for the TR control as provided in the maintenance manual, to be described later in 2.13.6 (3) and (5). As a result, the inspection for the ball pivot as provided in the maintenance manual to be described later in 2.13.6 (6) was not performed.

According to 2.13.6 (4) to be described later, the fact that the joint of the Rod and the yaw actuator is connected with a left-handed thread is provided in a clause about the disassembly and assembly procedures for the TR control rod on the maintenance manual. But this clause is not a clause which must be checked in periodic inspections. The clause relates only to cases in which parts replacement and others are required. A check on based on this clause is not usually performed in periodic inspections.

An inspection of the threaded area of the Rod had not been performed, because it is not required in the maintenance manual.

2.13.3 Locking Plate

(1) Installation of locking plate

As described in 2.9.2 (3), the locking plate was not found after the accident. Therefore, it cannot be confirmed whether the locking plate had been installed or not at the time of the accident. Hence, the matters related to the installation of the locking plate were confirmed with the Manufacturer, the Maintenance Service Company and the Company. The results of the confirmation are as follows:

① The Manufacturer

According to the records about the assembly of the TR control system when the Aircraft was on the production line, an inspection for assembly confirmation was performed and there was no abnormality with the assembly.

The Manufacturer had not received reports of the absence of locking plates for the same series type of aircraft after their manufacture, according to the Manufacturer.

② The Maintenance Service Company

According to the Maintenance Service Company, the mechanic who actually worked on the Aircraft said in an interview that he remembers that the locking plate had been installed with no looseness seen in the threaded area of the Rod when the inspection, as described in 2.13.2 (1), was performed by the Maintenance Service Company.

According to the Maintenance Service Company, the work records and the interview of the mechanic who worked on the Aircraft show that the threaded area of the Rod had not been disconnected or re-torqued when the inspection was performed by the Maintenance Service Company.

③ The Company

According to the Company, there were no records that the threaded area of the Rod had been disconnected at the Company. The Company had not committed maintenance service companies other than the Maintenance Service Company to maintain the Aircraft.

(2) Confirmation of torque value needed to loosen the threaded area of the same type of rod

As described in 2.13.1 (1), the mechanic stated: "Because the locking plate is installed

in this joint, it is generally believed that the Rod cannot be turned around easily. But I could turn around the Rod manually at that time.” Therefore, it was confirmed whether the threaded area of the same type of rod can be manually loosened in a condition in which the locking plate is installed. This was confirmed repeatedly. The result of the confirmation is as follows:

- ① The result of the measurement, performed on February 13, 2008, of a torque value necessary to loosen the threaded area was as follows:

The locking plate was put to the threaded area between the same type of rod and the yaw actuator and tightening it at about 50 lb-in within the torque value range of 44–53 lb-in as provided in the maintenance manual and then, by hitting the end of the locking plate with a hammer with a punch applied there and further swaging the bent end by pliers. When the torque was applied gradually between them in the direction of loosening, the joint between them loosened at about 30 lb-in, and the cut-off places of both end sections hit the bent end of the locking plate. When the torque was further applied, the cut-off places of both end sections turned around at about 35 lb-in beyond the bent end of the locking plate.

- ② It was confirmed on January 21, 2010 whether the threaded area can be manually loosened. The result was as follows:

The locking plate was put to the threaded area between the same type of rod and the yaw actuator and tightening it at about 50 lb-in within the torque value range of 44–53 lb-in as provided in the maintenance manual and then, by hitting the end of the locking plate with a hammer with a punch applied there and further swaging the bent end by pliers. In this condition, the threaded area of the same type of rod could be manually loosened in a certain case. When the threaded area was tightened once again at about 50 lb-in from this condition, it could not be manually loosened. Further after that, when the bent end of the locking plate was hit by a hammer with a punch applied there and the bent end was swaged by pliers, the threaded area of the same type of rod could be manually loosened in a certain case.

As described above, when the threaded area of the same type of rod remains tightened at about 50 lb-in, the threaded area cannot be manually loosened. But after that, when the end of the locking plate was hit by a hammer with a punch applied there and the bent end was further swaged by pliers, the threaded area could be manually loosened in a certain case. The cut-off places of end sections of the same type of rod and the yaw actuator turned around beyond the bent end of the locking plate and after it turned around one time, the bent end opened. This enabled it to turn around easily without a hitch.

- ③ A comment was sought from the Manufacturer about the result of the confirmation as described in ②. The Manufacturer made its own confirmation of the same phenomenon. As a result, it reached the conclusion that a torque for loosening may be slightly smaller than a torque for tightening but that it cannot be manually loosened in any condition, and it was basically concluded that the confirmation result obtained in Japan cannot be reconfirmed.

This made it clear that there is a difference between the result of the confirmation made with the Company’s cooperation and the opinion of the Manufacturer. Therefore, in accordance with a proposal by the Manufacturer, the phenomenon was confirmed once

again on May 13, 2010, by obtaining cooperation from the Manufacturer's general agent in Japan (hereinafter referred to as "the Agent") and the Maintenance Service Company as the Manufacturer's designated maintenance service company.

In the confirmation made by the Manufacturer itself, according to a photo provided by the Manufacturer, the locking plate was bent so that it is fully stuck to the cut-off places of the same type of rod and the yaw actuator, compared to the workmanship with which the locking plate was bent in the confirmation as described in ②. Therefore, the reconfirmation was made with a locking plate bent equivalently as did by the Manufacturer.

For confirmation, consideration was paid to the possibility that the torque value may decline due to an impact to be applied to the threaded area when the end of the locking plate will be hit by a hammer with a punch applied there, and the confirmation was made carefully so that the threaded area will not be hit excessively, while paying attention to the effect of the locking plate for preventing the same type of rod from turning around and the degree of power needed to manually turn around the threaded area of the same type of rod.

The torque value necessary for loosening the threaded area was also measured once again.

a. First round

When the end of the locking plate was hit by a hammer with a punch applied there and the bent end was further swaged by pliers, it could be bent equivalently as did by the Manufacturer. The threaded area could not be manually loosened.

Then, after the torque value was loosened with a tool to 0 lb·in, only the effect of the locking plate for preventing a turnaround was confirmed. The rod could not be turned around by fingers, but it could be turned around when both hands were used to tightly grasp the Rod and some force was applied.

b. Second round

After hitting the end of the locking plate with a hammer with a punch applied there and swaging the bent end further with pliers, it was bent equivalently as did by the Manufacturer. When the threaded area was manually confirmed with care, there was backlash and it had become loose.

Based on a. and the confirmation result mentioned above, when the end of the locking plate was hit with a hammer with a punch applied there and the bent end was swaged by pliers, it was confirmed that the threaded area loosens in a certain case. This confirmation result was the same as the confirmation result as described in ②.

Then, the effect of the locking plate for preventing a turnaround was confirmed. The rod could not be turned around by fingers, but it could be turned around when both hands were used to tightly grasp the rod and some force was applied.

c. Third round

Assuming that the threaded area will loosen with an impact when the end of the locking plate was hit by a hammer with a punch applied there, the end was swaged and bent with pliers without applying any force to hit the end.

The end of the locking plate could be bent by using only pliers equivalently as did by the Manufacturer. The threaded area was not loose, and it could not be manually loosened.

d. Remeasurement of torque value necessary to loosen the threaded area

Then, a torque value necessary to loosen the threaded area with a dial torque wrench was measured for the same type of rod with its end bent only by pliers and with the threaded area not loosened. The result was about 30 in-lb. The torque was further applied, but the torque was lost and the reading value declined. After that, the reading value increased again in its climb over the bent end of the locking plate. The reading value was about 30 in-lb when it turned around beyond the bent end.

This confirmation result was almost the same as the confirmation result described in ①.

Then, a torque value necessary to loosen the threaded area with a dial torque wrench was measured for the same type of rod tightened only with about 50 in-lb without bending the end of the locking plate. The result was about 35 in-lb.

e. Summary of confirmation results

(a) The effect of locking plate for preventing turnaround

Even if the end of the locking plate was bent equivalently as did by the Manufacturer, when the torque value is loose at zero lb-in, the threaded area cannot be turned around with fingers, but it was confirmed that when both hands were used to grasp the rod and some force was applied, the cut-off places of the end sections of the same type of rod and the yaw actuator turn around beyond the bent end of the locking plate.

(b) Bending with pliers

It became clear that the end of the locking plate can be bent equivalently as did by the Manufacturer also for the end which has been swaged by pliers to avoid an impact to be applied on the threaded area when the end of the locking plate is hit by a hammer with a punch applied there.

Overall, as to the confirmation results other than the two new findings as described in (a) and (b), it was basically possible to reappear the confirmation results as described in ① and ② .

④ Comments were sought from the Agent and the Manufacturer about the confirmation result described in ③. Their replies were as follows:

It has become known that a hammer's hit gives an excessive impact to components. Therefore, it is not a correct procedure to perform this bending work.

A correct procedure for bending the locking plate was confirmed. For bending the locking plate, a hammer and a punch has to be used only initially. The remaining bending work has to be accomplished by using pliers.

A procedure with a hammer used is not a correct procedure because it gives an excessive impact to components. Impacts shall not be given to the secured threaded component, and this is regarded as standard maintenance practice.

It became clear that the locking plate can be bent even only with pliers.

As mentioned above, the conclusions about the confirmation of the torque and the confirmation of the bending of the locking plate are as follows:

Judging from the confirmation conducted at the Manufacturer's plant for this case at an early time in 2010 and the general experience the Manufacturer holds about this case, as long as proper procedure has been applied, it is possible to appropriately secure the same type of rod and the yaw actuator. And it became clear

that the initial torque value will be kept and will not loosen even after a lapse of time.

As the yaw actuator has to be regarded as a sensitive electric device, an excessive hammering has to be avoided.

2.13.4 Information about Ball Pivot and Threaded Area of the Same Type of Rod for Same Series Type of Aircraft

(1) The Company

The Company had maintained and operated six aircraft of the type of aircraft other than the Aircraft when this accident occurred.

After the occurrence of the accident, the Company performed inspections of the ball pivot and the threaded area of the same type of rod for the six aircraft. According to the Company, the conditions of the ball pivot and the threaded area of the same type of rod seen in the inspections were as follows:

A corroded ball pivot was found with one aircraft, and the ball pivot was replaced.

In an inspection of the threaded area of the same type of rod, any backlash was not found for all the six aircraft and it could not be manually loosened. No damage was found, either, when the threaded area was disconnected.

(2) The Manufacturer

After the occurrence of this accident, operators with the same series type of aircraft around the world performed inspections of the ball pivot and the threaded area of the same type of rod for aircraft concerned in their respective fleets. According to the Manufacturer, the conditions of the ball pivot and the threaded area of the same type of rod as reported from each operator to the Manufacturer were as follows:

According to the reports, blocked/fixed ball pivots were found for 30 to 40 aircraft.

As to the threaded area of the same type of rod, any loosening and any damage due to flight were not reported.

(3) The Agent

According to the Agent, all the 53 aircraft in the same series type of aircraft registered in Japan had been equipped with the new type of rod as of August 10, 2010. The new type of ball pivot had been installed with 52 aircraft except for 1 aircraft.

2.13.5 Base Where the Aircraft was Stationed

After the Aircraft was introduced for the Company as a production new aircraft, according to the Company, it was assigned to its base at Nagoya Airport located in an inland area. Then, it was deployed to its base at Niigata Airport located in a coastal area on November 23, 2005.

2.13.6 Maintenance Manual

The following remarks are included in the maintenance manual issued by the Manufacturer (Excerpt):

(1) Periodical Inspection

Time Limits – Scheduled Inspections

6-5 Periodical Inspection – Time Limits

A. A Periodical Inspection is to be performed according to section 05-24-00:

(Omitted)

–Then every 800 flight hours or every three years, whichever occurs first.

(2) Maintenance Items

Periodical Inspection

6-1 Periodical Inspection

Rotor Flight Controls

(Omitted)	<i>Required measures</i>	<i>References</i>	(Omitted)
(Omitted)	(Omitted)	(Omitted)	
	<i>(5) Remove yaw actuator. Inspect tail rotor flight controls.</i>	(Omitted) <i>67-20-00, 6-1</i>	
	(Omitted)	(Omitted)	

(3) Troubleshooting of the TR Control

67-20-00, 1-1 Tail Rotor Controls – Troubleshooting

D. Procedure:

- 2. If admissible breakout forces on the pedals are exceeded, perform troubleshooting of tail control i.a.w. table 1:*

Table 1. Troubleshooting – Tail Rotor Control

<i>Trouble Symptom</i>	<i>Possible Cause</i>	<i>Corrective Action</i>
<i>Stiff tail rotor control</i>	(Omitted)	(Omitted)
	<i>Stiff aft ball pivot.</i>	<i>Check ball pivot for stiffness (67-20-00, 6-1). If necessary, replace ball pivot (67-20-00, 8-5).</i>
	(Omitted)	(Omitted)

(4) Disassembly and Assembly of the TR control rod

67-20-00, 4-12 Disassembly / Assembly – Yaw Actuator

D. Procedure:

- 2. Disassemble yaw actuator*

c.

NOTE

The thread with the control rod is screwed into the actuator is a left-handed thread.

d.

NOTE

The rod end bearing of the control rod is adjusted when the non-boosted section of the tail rotor controls is adjusted. When the control rod is disassembled, the non-boosted section of the tail rotor controls must be newly adjusted following installation.

- 3. Assemble yaw actuator:*

- c. Screw control rod with locking washer into actuator. Tighten control rod to a torque of 5-6 Nm (44-53 lb. in) and secure it with locking washer.*

(5) Inspection of the Control Force of the TR Control

67-20-00. 5-2 Ease of Movement Check – Tail Rotor Control

Effectivity : without 3-Axis Autopilot System

D. Procedure

1. *Connect external pump drive to pressure system 2 and switch on.*
4. *Move pedal from center position by using the spring balance 2-3 cm (0.8 – 1.2 in), read out breakout force occurring from spring balance and note. Carry out the measurement three times and calculate the mean value from all three measured values.*

Breakout force on the LH pedal may not exceed a mean value of a maximum of 60 N (13.5 lb). If the breakout force exceeds this maximum value, perform troubleshooting of tail rotor control.

6. (Omitted)

The breakout force on the RH pedal may not exceed a mean value of a maximum of 45 N (10.1 lb). (Omitted)

(6) Inspection of Ball Pivot

67-20-00, 6-1 Inspection –Tail Rotor Controls

D. Procedure:

7. *Inspect aft connection end of the ball bearing control:*
 - b. *Inspect ball pivot for corrosion and stiffness of movement. If corroded or stiff: replace ball pivot.*

2.14 Information about Flight Control by Captain

2.14.1 Statement of a Pilot Checker of the Company

In periodic training and periodic check for the captain, as a pilot checker, I qualified the captain as a captain of the Company and passed him in the examination on February 2007. In the periodic training and periodic check, a syllabus for the TR failure was not implemented.

The captain had experience of work at the base at the Heliport in the past. In February 2003, when he was flying on board an Aerospatiale AS355F2 helicopter, a twin-engine rotorcraft, the No. 1 engine failed. At that time, he landed on the apron of the Heliport while running about 1 m in the direction of 06. Because the apron at the Heliport is vast, I think that running landing may be possible if space is available at the apron. The Heliport is surrounded by hills close at hand to the north, the east and the west, and it is open only to the south. In the flight at the time of the accident, the Aircraft made an approach to the Heliport from the south. In a training flight with the same type of aircraft performed by the Company after the accident, it was found that a wide air space is necessary for a go-around in such a situation as this case in which the Aircraft's TR failure. When I think about it now, the situation was difficult for the Aircraft to perform a go-around in view of the geographical features, at a time when the accident occurred with its TR failure, making it impossible to fully use its engine power. I do not think the Heliport was an appropriate place for landing.

The Aircraft decelerated at a point about 800 m short of the Heliport on its final approach route, but the Heliport was still far from there. I think the deceleration was not aimed at landing. I think the captain was rather trying to confirm the Aircraft's behavior prior to a deceleration for landing at an altitude which is high enough for a go-around.

2.14.2 Information about Landing Areas Near Place Where Malfunction Occurred

According to the statement of the mechanic on board as described in 2.1.2, a malfunction was

occurred on the Aircraft after flying over around Lake Ashinoko. Following are airbases, a gliding field, and a temporary airfield which are reachable from around the lake in about 1 h and 50 min in terms of the Aircraft's estimated fuel load expressed in endurance:

(1) Fujigawa Gliding Field

About 13 nm east-northeast of the Heliport, field elevation of 2 ft, the runway direction at 18/36, the runway 850 m long and 30 m wide, managed by the Shizuoka Prefecture Aeronautic Association.

(2) Shizuhama Airbase

About 14 nm southwest of the Heliport, field elevation of 23 ft, the runway direction at 09/27, the runway 1,500 m long and 45 m wide, managed by the Japan Air Self-Defense Force.

(3) Miho Temporary Airfield

About 6 nm east of the Heliport, field elevation of 9 ft, the runway direction at 15/33, the runway 500 m long and 20 m wide, managed by the Japan Flying Association.

(4) Hamamatsu Airbase

About 39 nm west-southwest of the Heliport, field elevation of 150 ft, the runway direction at 09/27, the runway 2,550 m long and 60 m wide, managed by the Japan Air Self-Defense Force.

(See Figure 1 Estimated Flight Route)

2.14.3 Flight Manual

The flight manual includes the following remarks regarding the TR failure: There are also similar remarks in the Company's operations manual and an abnormality check list which had been equipped for the Aircraft. (Excerpt)

SECTION 3 EMERGENCY AND MALFUNCTION PROCEDURES

3.1 GENERAL

3.1.1 Basic rules

These procedures deal with common emergencies. However, they do not prevent the pilot from taking additional action necessary to recover the emergency situation.

Although the procedures contained in this Section are considered the best available, the pilot's sound judgment is of paramount importance when confronted with an emergency.

To assist the pilot during an inflight emergency, three basic rules have been established:

1. Maintain aircraft control

2. Analyse the situation

3. Take proper action

NOTE It is impossible to establish a predetermined set of instructions which would provide a ready-made decision applicable to all situations.

3.1.2 Memory Items

Emergency procedure steps which shall be performed immediately without reference to either this Manual or the pilot's checklist are written in boldface letters on a gray background (as shown here) and shall be committed to memory.

Therefore, those emergency procedures appearing without boldface letters on a gray background may be accomplished referring to this Manual, and when time and situation permit.

3.6 TAIL ROTOR FAILURE CONDITIONS

3.6.2 Tail Rotor Drive Failure/Fixed-pitch Tail Rotor Control Failure – Forward Flight Conditions /Indications

- No directional response after pedal inputs and/or
- Complete loss of tail rotor thrust and/or
- Locked pedals

NOTE The procedure will vary depending on flight conditions, power setting and mass of the helicopter

Procedure

1. Collective Lever - Reduce to obtain minimum sideslip angle

2. Airspeed - Maintain 70 KIAS or higher

3. suitable landing area - Select

NOTE • Surface of the landing area should be hard (e.g. concrete, asphalt) and flat.
• Crosswind from the left is advantageous

4. Shallow approach with nose left - Perform

If the airspeed can be reduced below 40 kts with the nose still pointing to the left:

5. Airspeed - Reduce close to the ground until nose is aligned with the flight direction

6. landing - Perform

If the nose direction changes from left to right at airspeeds higher than 40 kts:

5. Airspeed - Increase

6. Approach - Abort, climb to sufficient height for autorotation

NOTE Headwind is advantageous

7. Autorotation - Perform

NOTE • In autorotation Zero sideslip can be expected at about 60 to 70 kts.
• Before touchdown, the groundspeed should be reduced to a minimum.
• In final phase of flare the helicopter can yaw to the left due to friction effects.

3. ANALYSIS

3.1 Qualification of Personnel

The captain held both a valid airman competence certificate and a valid aviation medical certificate.

3.2 Airworthiness Certificate of the Aircraft

The Aircraft had a valid airworthiness certificate.

As described in 2.13.1 (1) and 2.13.2 (2), troubleshooting for the TR control system was not performed in accordance with the TR control troubleshooting procedures provided in the English written maintenance manual as described in 2.13. 6 (3) and (5). As a result, an inspection of the ball pivot as described in 2.13.6 (6) was not performed.

As described in 2.13.1 (1), the mechanic mentioned that when he tried to reconnect the Rod disconnected from the input lever of the Fenestron servo actuator, he felt looseness in the joint of the Rod and the yaw actuator and therefore, he manually turned around the Rod to the right to tighten the joint.

As described in 2.13.6 (4), the fact that the joint portion is fixed with a left-handed thread is

provided in the clause about the disassembly and assembly procedure for the Rod in the maintenance manual. But this clause was not implemented in routine periodic inspections. This is a procedure which is implemented only for such cases as parts replacement.

Prescribed maintenance and inspections other than those mentioned above had been implemented.

3.3 Relations to Meteorological Condition

It is considered highly probable that the meteorological condition at the time of the accident was not related to the occurrence of this accident.

3.4 TR Failure

3.4.1 The Cause for Lack of Smoothness in the TR Control

According to the following reasons, it is considered highly probable that the cause for the malfunction, which had occurred before the accident, that the TR control lacks smoothness had been a corroded and stiff ball pivot:

- (1) As described in 2.13.1, conditions with heaviness or lack of smoothness felt in the rudders occurred in rudder operations with the left rudder pedal fully depressed just after the start of flight. Malfunction with the TR control system had occurred before the accident, though such a symptom was not reappeared after that.
- (2) As described in 2.9.2 (3), the ball pivot had become stiff.
- (3) As described in 2.12.2, the position where the ball pivot had become stiff was almost the same as the position where the hydraulic pressure for the Fenestron servo actuator is inoperative. The displacement of the aft end of the Rod from the position in the lateral direction where the ball pivot had become stiff and the bending load applied to the Rod increased when the TR pitch angle was shifted to the high pitch side.
- (4) Malfunction with sliding surface which became stiff due to corrosion generally occurs when the areas are left with no movement for sliding in a time span which is necessary for progress of corrosion. If the sliding surface is moved forcibly and stiffness is freed, such a symptom rarely reappears.
- (5) A possible cause for the symptom that the TR control lacks smoothness is believed to be a stiff ball pivot, according to the trouble shooting procedures for the TR control provided in the maintenance manual as described in 2.13.6 (3). Therefore, it must be checked whether the ball pivot has become stiff and if necessary, the ball pivot must be replaced, provided as a corrective action. However, as described in 2.13.2 (2), the inspection of the ball pivot was not performed in trouble shooting on October 20, 2007.

3.4.2 The Cause for Loss of Control TR

Based on the following reasons, it is considered highly probable that the rupture of the Rod had occurred during the flight, not due to an impact at the time of the crash: At about past 10:30, when the Aircraft passed over around Lake Ashinoko, TR suddenly became uncontrollable, and it is considered highly probable that this malfunction had been caused by the rupture of the Rod.

- (1) As described in 2.1, when the Aircraft passed over around Lake Ashinoko at about past 10:30, TR suddenly became uncontrollable. Then, the Aircraft flew with the nose deflected to the right, and banking to the left.
- (2) As described in 2.9.2 (3), the TR drive shaft had been separated from the main gear box and

the flex coupling had been distorted. From this fact, it is considered highly probable that this damage occurred due to a tension load applied on the TR drive shaft in the direction of its axis following the impact at the time of the crash, and so that the TR drive shaft had not been damaged until the time of the crash.

- (3) The Rod had ruptured, but as described in 2.9.2 (1), the degree of damage seen in the areas aft from the tail boom was less than that on the fuselage. Also as described in 2.9.2 (3), the ball bearing control, when removed from the Aircraft, was able to travel, and it had not ruptured.
- (4) As described in 2.12.3 (1) and 2.12.4 (1) ④, based on an observation of the fracture surface of the Rod, it is considered highly probable that the Rod had failed by fatigue.

3.4.3 TR Pitch Angle after Rupture of the Rod

- (1) Based on the following reasons, it is considered highly probable that after the Rod ruptured, the input lever of the Fenestron servo actuator was displaced to the most aft position where the TR pitch angle becomes the minimum pitch angle and remained at the position.
 - ① As described in 2.1.2, the mechanic on board states that the Aircraft suddenly started swinging and then the Aircraft became in an attitude with its nose deflected to the right and banked to the left.
 - ② As described in 2.6.6 (5), the input lever of the Fenestron servo actuator juts out to the left side. When it is displaced backward, the TR blades become a low pitch angle.
 - ③ As described in 2.12.1, the most aft of the straight striated scratch mark on the Rod was located at a place about 42 % in the longitudinal direction on the Rod from the minimum pitch angle position. Therefore, it is considered highly probable that the TR pitch angle when the Rod ruptured was a position about 42 % on the high pitch side from the minimum pitch angle position in the longitudinal direction on the Rod. A metal underneath had been exposed with a paint stripped at the place where the TR pitch angle has the minimum pitch angle. As a result, it is considered highly probable that the Rod had remained stuck at the position where the TR pitch angle has the minimum pitch angle with contacting to the edge of the through hole of Fenestron, until the time when the paint was stripped and the metal underneath was exposed.
- (2) As described in 2.12.8, when the hydraulic system of the mock-up model for maintenance training was activated for confirmation, the input lever of the Fenestron servo actuator moved only with an extremely light force applied. Once it started moving, the input lever continued to move on even in a hands-off condition. Therefore, the phenomenon after the rupture of the Rod, as described in (1), that the input lever was displaced to the most aft position where the TR pitch angle has the minimum pitch angle and remained at the position had occurred because the input lever had been displaced to that position due to air pressure generated in a forward flight and it had been kept at the position.
- (3) As described in 2.1.2, the mechanic on board states that “The captain was controlling the Aircraft while fully depressing the left rudder pedal and when he slightly returned the pedal, the Aircraft’s attitude worsened.” Therefore, after the Rod ruptured, as described in (2), it is considered somewhat likely that because the captain moved the rudder pedal before the TR pitch angle would have become the minimum pitch angle due to wind pressure, so that the front end of the ruptured Rod was pushed backward by the aft end of the yaw actuator and as a result, the input lever of the Fenestron servo actuator started moving

backward, causing the TR pitch angle to shift to the low pitch side.

3.4.4 Influence of Rupture of the Rod on Flight Control

- (1) Based on the following reasons, it is considered highly probable that, the reason why the Aircraft continued flying with the nose deflected to the right and its attitude banked to the left after the Rod ruptured as described in 2.1, is the fact that TR generated the thrust that deflect the nose to the right.
 - ① As described in 3.4.3, it is considered highly probable that after the Rod ruptured, the input lever of the Fenestron servo actuator was displaced to the most aft position where the TR pitch angle becomes the minimum pitch angle and remained at the position.
 - ② As described in 2.6.5, TR of the Aircraft is capable of generating a thrust which deflects the nose to the right in an autorotation flight. As described in 2.6.6 (5), the TR blade pitch angle at the minimum pitch angle position has a reverse pitch from the thrust which generates in a power-on flight.
 - ③ As described in 2.12.7, a flight test with the same series type of aircraft and a test with flight simulator were performed at the Manufacturer. The condition of the Aircraft's TR failure at the time of the accident could be reappeared with the right rudder pedal depressed to the maximum position and the nose deflected to the right.
- (2) When the Aircraft was continuing a cruising flight after the rupture of the Rod until it reaches around over the accident site, the strength of the torque to deflect the nose to the right was within the range where a forward flight is possible. As the forward speed declines, the lift of the vertical stabilizer to deflect the nose to the left decreases and as the engine power increases, the reactive torque of MR to deflect the nose to the right increases. Therefore, it is considered highly probable that in the failure condition, as described in (1), where TR generates a thrust to deflect the nose to the right, as the forward speed declines and the engine power increases, the balance for the forward flight will be finally lost and as a result, the aircraft will shift to rotating to the right and become uncontrollable.

Therefore, in order to continue the Aircraft's flight with the Rod ruptured, attention must have been paid to keep the balance between its engine power and its speed.

3.5 Landing after Rupture of the Rod

3.5.1 Selection of Landing Area

- (1) As described in 2.1.2, the mechanic on board states that "I told the captain that it would be better for us to land on a long runway or a dry riverbed rather than the Heliport but the captain said he would try running landing or autorotation landing on the Heliport. The following reasons can be considered as factors that led him to select landing on the Heliport despite the mechanic's advice:
 - ① As described in 2.1, the Heliport was the destination aerodrome in the flight plan.
 - ② As described in 2.14.1, the captain had experience of work at the Heliport in the past and he had performed emergency running landing on the apron of the Heliport. Therefore, it is considered somewhat likely that he might have concluded in this accident flight, too, that running landing or autorotation landing on the Heliport would be possible.
 - ③ Because the Company has a base at the Heliport, it is considered somewhat likely that the captain had understood that Heliport has more advantage for them to get support after landing than at other landing areas where there is no base for the Company.

- (2) As described in 2.1, the Aircraft decelerated in the air around the accident site. As described in 2.12.7 and 3.4.4, a wide air space is necessary around the landing area when a go-around is performed, because it is difficult to control the Aircraft that needs a strong engine power in a slow forward speed. But as described in 2.8, the Heliport is surrounded by hills in the direction forward and on the right and left sides, from the direction the Aircraft approaching. As a reason for his attempt to land on such a place, it is considered probable that the captain did not recognize that a wide air space is necessary for a go-around because the engine power and the speed must be well balanced in controlling the Aircraft.
- (3) As described in 2.14.3, the flight manual refers to “suitable landing area ” for cases of “TAIL ROTOR FAILURE CONDITIONS” provides that “Surface of the landing area should be hard (e.g. concrete, asphalt) and flat” and that “Crosswind from the left is advantageous. Therefore, it is considered highly probable that the captain tried to select a landing area in accordance with the flight manual.

As described in 2.12.7 and 3.4.4, the flight test and the test with flight simulator performed at the Manufacturer after the accident found that a wide air space is necessary to perform a go-around in this TR failure condition of the Aircraft. Therefore, it is desirable to add the description that a wide air space is necessary for a go-around to the description in “suitable landing area” for cases of “TAIL ROTOR FAILURE CONDITIONS ” in the flight manual.

3.5.2 Operations just before Crash

- (1) As described in 2.1, the Aircraft decelerated in the air around the accident site about 800 m short of the Heliport, but the Heliport was still far from there. It is considered probable that the deceleration was not aimed at landing. As suggested in the statement of the Company’s pilot checker, as described in 2.14.1, it is considered somewhat likely that the captain was trying to confirm the Aircraft’s behavior when it decelerates for landing, at an altitude which is high enough for a go-around.
- (2) But as described in the statement of the mechanic on board in 2.1.2, the Aircraft was already flying with the nose deflected to the right during the cruising flight until the time when it reached around the accident site after the rupture of the Rod. This was a condition which falls under a description of “If the nose direction changes from left to right at airspeeds higher than 40 kts;” in the flight manual as described in 2.14.3. Therefore, the captain should not have decelerated.
- (3) As described in 2.12.6 (1), the Aircraft’s nose was greatly lowered about 11 s before the crash, but it did not accelerate toward the flight direction. Then, it started gradually rotating to the right and about 10 s before the crash, its rotation to the right accelerated with the altitude kept unchanged. Therefore, it is considered highly probable that the captain shifted to a nose-down attitude for a go-round and performed an operation to increase the engine power.
- (4) As described in 3.4.4, an operation to increase the engine power while keeping a low speed in this TR failure condition of the Aircraft is the severest operation to accelerate the rotation to the right. As a result, it is considered highly probable that the Aircraft became uncontrollable and rapidly lost its altitude.
- (5) As described in 2.14.1, the pilot checker of the Company states that a syllabus for TR failure was not implemented in the periodic training and periodic check for the captain.

- (6) This TR failure condition of the Aircraft falls under a description of “If the nose direction changes from left to right at airspeeds higher than 40 kts” in the flight manual as described in 2.14.3. In this case, the speed must be accelerated and after climbing to an enough altitude, autorotation landing must be performed, as provided in the flight manual.
- (7) In the flight manual described in 2.14.3, an emergency procedure for TR failure is provided as “Emergency procedure steps which shall be performed immediately without reference to either this Manual or the pilot’s checklist” and as “Memory Items”.
- (8) As described in 2.1.2, the mechanic on board states that after the Aircraft’s TR became uncontrollable during its flight, neither she nor the captain looked at the emergency procedure for TR failure provided in the flight manual.

Judging from the factors mentioned above, it is considered highly probable that the captain did not perform operations in accordance with the Aircraft’s flight control characteristics in cases with its TR failure, as described in 2.12.7.

The captain should have accelerated the Aircraft and performed autorotation landing after climbing to an enough altitude in accordance with the emergency procedure for TR failure in “Memory Items ” as provided in the flight manual, which falls under this TR failure condition of the Aircraft.

3.6 Factors for Survival at the Time of Crash

3.6.1 Crash Site

As described in 2.9.1, the site where the Aircraft crashed happened to be a marsh. Therefore, it is considered highly probable that the impact on the Aircraft was easier than when it had crashed on a hard ground.

3.6.2 Fastening of Shoulder Harness

Judging from the statement of eyewitness C as described in 2.1.3 (3) and the condition of the seats of the Aircraft as described in 2.9.2 (6), it is considered highly probable that the captain was fastening the seat belt but he was not fastening the shoulder harness. As described in 2.10 (1), regarding the fact that the cause for the captain’s death was damage to the heart, it is considered highly probable that because he had not fastened his shoulder harness, his body bent forward due to the impact of the crash and he had the chest hit with the cyclic stick. It is considered somewhat likely that the captain would not have had the chest hit with the cyclic stick and he would not have died only if he had fastened the shoulder harness.

3.7 The Cause for Stiffening of Ball Pivot

Judging from the opinion of the NIMS as described in 2.12.3 (2), it is considered highly probable that the stiffening of the ball pivot had occurred because red rust created with the corrosion of the contact surface of the outer ring, an iron-based alloy, because of galvanic corrosion or crevice corrosion in the contact surface between the inner ring as a copper-based alloy and the outer ring as an iron-based alloy caused volume expansion in the space between the two rings and this restricted the movement of the two rings.

3.8 Factors for Rupture of the Rod

Judging from the opinions of the NIMS, the Manufacturer and the JAXA as described in 2.12.3, 2.12.4 (2) and 2.12.5, it is considered highly probable that the factors for the rupture of the Rod

were as follows.

In the situation in which the ball pivot becomes stiff, and when the pilot depresses the left rudder pedal and operates the TR control to the high pitch angle side, the bending load on the Rod increases and when the yaw actuator is moved in this condition, the bending load on the Rod further increases. In this condition, a resonance phenomenon due to the airframe vibrations occurs on the Rod.

Furthermore, as described in 3.2, it is considered highly probable that there was looseness in the joint between the Rod and the yaw actuator. Therefore, it is considered highly probable that because stress concentration occurred on the threaded area of the Rod, repetitive bending loads in excess of the fatigue strength were applied on the threaded area of the Rod and as a result, fatigue failure developed and caused its rupture.

3.9 The Threaded Area of the Rod

3.9.1 The Time When Looseness Occurred

- (1) As described in 2.13.1 (1), the mechanic mentioned that in trouble shooting for the TR control system performed on October 20, 2007, looseness was found in the joint of the Rod and the yaw actuator and therefore, he manually turned the rod to the right to tighten the joint. Hence, it is considered highly probable that there had been looseness in the joint of the Rod and the yaw actuator before the troubleshooting was performed.

As described in 2.13.3 (1) ① and ②, the mechanic who worked on the Aircraft in the inspection performed by the Maintenance Service Company remembers that the locking plate had been installed with no looseness seen in the threaded area of the Rod. There were no records that the threads area of the Rod had been disconnected or re-torqued, neither the records that the threaded area of the Rod had been disconnected at the Company. Further, the Company had not committed the maintenance of the Aircraft to maintenance service companies other than the Maintenance Service Company. Judging from these factors, it is considered highly probable that looseness had occurred in the joint of the Rod and the yaw actuator sometime after the periodic inspection performed by the Maintenance Service Company on March 9, 2006, 368 h 25 min in flight time before the occurrence of the accident.

- (2) As described in 2.13.1 (1), the mechanic mentioned that when he reconnected the Rod which had been disconnected from the input lever of the Fenestron servo actuator in the trouble shooting, he might have connected the Rod and the input lever in a condition where the joint was turned to the direction of loosening from the condition before the joint of the Rod and the yaw actuator was disconnected. Regarding the installation of the locking plate as described in 2.13.3 (1), related matters were confirmed with the Manufacturer, the Maintenance Service Company and the Company. It is considered highly probable that the locking plate had been installed when the accident occurred. Therefore, it is considered somewhat likely that although the locking plate had been installed, it had been reconnected in a condition where the joint was turned to the direction of loosening from the condition before the Rod and the input lever were disconnected.

As described in 2.9.2 (3), the following reasons can be considered probable as factors that the locking plate was not found after the accident:

As described in 2.6.6 (4), the locking plate had been installed with the threaded area of the ruptured Rod. Therefore, it is considered probable that when the Rod ruptures, the

locking plate falls out into the Fenestron. It is considered probable that the locking plate which had fallen into the Fenestron fell into the marsh through a hole in the lower part of the Fenestron, which is certain to have been created due to the impact at the time of the crash, as described in 2.9.2 (1).

- (3) As described in 2.13.3 (2), it is considered probable that when the locking plate is fixed by bending its edge by a tool after tightening the threaded area of the Rod at about 50 lb-in, the threaded area loosens in a certain case due to impact in the work and others.

But, as described in (1), the threaded area of the Rod had not been disconnected or re-torqued after the periodic inspection performed by the Maintenance Service Company. According to the information provided by the Company and the Manufacturer about the condition of the threaded area of the Rod, as described in 2.13.4, there were no reports that the threaded area became loose due to flights. As a result, reasons could not be found for the loosening of the threaded area occurred sometime after the periodic inspection performed by the Maintenance Service Company.

- (4) As described in 2.13.3 (2) ④, the opinion of the Manufacturer is that if an appropriate procedure for bending the locking plate is followed, it is possible to tighten the Rod and the yaw actuator in an appropriate manner and that the initial torque will be kept without looseness even after time passed.

But as it shows in the confirmation test as described in 2.13.3 (2), looseness occurs in a certain case, depending on the work procedures. It is considered probable that the bending work for the locking plate will be performed, when necessary, not only by the Manufacturer but also by operators. But there are no notes about the work procedures in the maintenance manual as described in 2.13.6. Attention must be paid so that an excessive impact will not be applied during the work, but it is considered probable that the possibility cannot be eliminated that operators take procedures with excessive impacts to be applied by hitting. Therefore, it is also considered probable that the possibility cannot be eliminated, either, that the locking plate becomes unable to prevent the threaded area from turning around.

3.9.2 The Time When a Crack Created

Based on the following reasons, it is considered highly probable that the ball pivot had become stiff sometime after the periodic inspection performed by the Maintenance Service Company on March 9, 2006, 368 h 25 min in flight time before the occurrence of the accident and caused a crack to develop in the threaded area of the Rod:

- (1) As described in 2.12.4 (2), the Manufacturer, in reference to factors that led to the rupture of the Rod, states that it is considered highly probable that when the ball pivot is not stiff, fatigue failure will not occur even with looseness in the threaded area of the Rod, but that when the ball pivot was stiff, the Rod would be exposed to repetitive bending loads in excess of the fatigue strength, and then fatigue failure would occur.
- (2) As described in 2.12.4 (1) ④, the Manufacturer states that in an observation of the fracture surface of the Rod, the condition around the starting point of the crack indicated the crack developed due to corrosion fatigue, and that oxygen and chlorine were detected in a material content analysis of the fractured surface. Therefore, it is considered highly probable that fatigue failure had occurred when the Aircraft was stationed in a coastal area, with signs of salt-linked oxidization observed in the fractured surface around the starting point of the crack.

As described in 2.13.5, the Aircraft was deployed to the base at Niigata Airport in a coastal area on November 23, 2005 from the base at Nagoya Airport in an inland area.

- (3) As described in 2.12.5, JAXA states as follows about the time when a crack created in the threaded area of the Rod:

Any judgment cannot be made as to the time span from the creation of damage to the appearance of a visible crack.

According to the Manufacturer's analysis, the Rod has a fatigue life of 3,211 flight hours in a condition where the ball pivot is stiff and the threaded area is loose. This does not include an influence which may be considered in the corrosion environment. When the possible effects of corrosion are considered, there is a possibility that the fatigue life becomes shorter. But a judgment cannot be made as to whether the fatigue life falls below 50 flight hours or not.

- (4) As described in 2.13.6 (1) and (2), the maintenance manual provides that the periodical inspection for the TR control system including the ball pivot is to be performed every 800 flight hours or every three years, whichever occurs first. As described in 2.6.1, a periodical inspection for the Aircraft was performed by the Maintenance Service Company on March 9, 2006, 368 h and 25 min in flight time before the occurrence of the accident. As described in 2.13.2, the records on the periodical check show there was no abnormality with the ball pivot.

3.9.3 Probability of Finding a Crack

As described in 2.13.2, the maintenance manual does not require the inspection of the threaded area of the Rod, including the periodic inspection of the TR control system which must be performed with a frequency of every 800 flight hours or every three years, whichever occurs first, which is provided in the maintenance manual as described in 2.13.6 (1), (2) and (3), as well as the trouble shooting procedure for the TR control system.

Therefore, it is considered probable that the probability was small that the crack in the threaded area of the Rod had been found in the troubleshooting procedure for the TR control system performed on October 20, 2007.

4. CONCLUSIONS

4.1 Findings

- (1) Rupture of the Rod

- ① The maintenance manual provides that the periodical inspection of the TR control, including that of the ball pivot, must be performed every 800 flight hours or every three years, whichever occurs first. A periodical check for the Aircraft was performed by the Maintenance Service Company on March 9, 2006, 368 h 25 min in flight time before the occurrence of the accident. But there was no looseness in the threaded area of the Rod. There was no abnormality with the ball pivot, either.

But it was stated that it was possible to turn around manually the threaded area of the Rod in the trouble shooting for the TR control system performed on October 20, 2007, 45 h 35 min in flight time before the occurrence of the accident.

Therefore, it is considered highly probable that the threaded area of the Rod had become loose and the ball pivot had stiff sometime after the periodical inspection performed by the Maintenance Service Company and as a result, a crack created in the

threaded area of the Rod.

- ② There were no records that the threaded area of the Rod had been disconnected and re-torqued after the periodical inspection performed by the Maintenance Service Company. According to information provided by the Company and the Manufacturer about the condition of the threaded area of the same type of rod, there were no reports that the threaded area had become loose due to flight. As a result, reasons could not be made clear about the phenomenon that the threaded area had become loose sometime after the periodical inspection performed by the Maintenance Service Company.
 - ③ Troubleshooting was performed on October 20, 2007, in pursuit for the causes for the unusual feeling in the rudder pedal movement, which had been reported by several pilots. But because the inspection was not performed in accordance with the troubleshooting procedure provided in the maintenance manual, the stiffening of the ball pivot was not found. It is considered highly probable that after the troubleshooting, the Aircraft was flying with the looseness left in the threaded area of the Rod.
 - ④ After the accident, it was found that the Rod had ruptured in the threaded area. In view of the result of an observation of the fracture surface, it is considered highly probable that the Rod developed fatigue failure due to repetitive loads.
 - ⑤ After the accident, it was found that the ball pivot had become stiff in the sliding surface due to corrosion. It is considered highly probable that the unusual feeling in the rudder pedal movement, which had been reported by several pilots, was caused by the stiffening of the ball pivot in light of remarks in the maintenance manual.
 - ⑥ As to the stiffening of the sliding surface of the ball pivot, it is considered highly probable that the phenomenon had occurred because red rust created with the corrosion of the contact surface of the outer ring, an iron-based alloy, because of galvanic corrosion or crevice corrosion in the contact surface between the inner ring as a copper-based alloy and the outer ring as an iron-based alloy caused volume expansion in the space between the two rings and this restricted the movement of the two rings.
 - ⑦ As to the rupture of the Rod, it is considered highly probable that because bending loads on the Rod had increased according to operating the rudder pedal and the movement of the yaw actuator in the conditions of the loosening of the joint of the Rod and the yaw actuator and the stiffening of the ball pivot due to corrosion, and also because a resonance phenomenon with the airframe vibrations and stress concentration due to the loosening of the joint had occurred on the Rod, repetitive bending loads in excess of the fatigue strength had been applied on the Rod.
- (2) Flight control
- ① It is considered highly probable that the Rod ruptured while the Aircraft was flying and as a result, TR became uncontrollable.
 - ② Judging from the fact that the Aircraft was flying with the nose deflected to the right after the Rod ruptured and the scratch mark found on the painted surface of the Rod, it is considered highly probable that after the rupture of the Rod, the input lever of the Fenestron servo actuator had been displaced to the most aft position where the TR pitch angle becomes the minimum pitch angle due to air pressure generated in a forward flight and it had been kept at the position. It is considered highly probable that TR was generating a thrust which deflects the nose to the right.
 - ③ The captain did not select any landing area with a runway with a wide air space

available around as a landing area for the Aircraft with this TR failure condition and instead, he decided to land on the Heliport which is the destination aerodrome under the flight plan and has a base for the Company. As far as the geographic features in the surrounding areas, the Heliport is surrounded by hills to the north, the east and the west and it is open only to the south. The Aircraft approached the Heliport from the south in its flight at the time of the accident.

- ④ The Aircraft deflected the nose to the right about 20 minutes after the Rod ruptured during its flight and after that, while keeping the attitude unchanged, it reached a point near the accident site on its approach route about 800 m short of the Heliport.
- ⑤ The Aircraft, when it decelerated, shifted gradually rotating to the right. Then, it shifted to a nose-down attitude. After the rotation to the right accelerated with the altitude kept unchanged, the Aircraft rapidly lost its altitude and crashed.
- ⑥ Regarding the Aircraft's behavior as mentioned above, it is considered highly probable that because the Aircraft shifted gradually rotating to the right when the captain performed an operation for deceleration, he tried to shift to a nose-down attitude by pressing the cyclic stick forward to perform a go-around and he also tried to increase the engine power by raising the collective lever up.
- ⑦ Following these operations, it is considered highly probable that the reactive torque on the MR rotations increased due to an increase in the engine power in a condition where the forward speed is slow and the lift by the vertical stabilizer to deflect the nose to the left is limited, on the contrary, the Aircraft became uncontrollable with its rotation to the right accelerated.
- ⑧ As a result of a flight test and a test with flight simulator performed at the Manufacturer after the accident, it was found that a wide air space is necessary to perform a go-around for the Aircraft in this TR failure condition.

(3) Impact at the Time of Crash

- ① Because the Aircraft crashed on a marsh with its landing gear first hitting the ground, it is considered highly probable that the impact to the Aircraft was easier than when it crashed on a hard ground.
- ② The cause for the captain's death was damage to the heart. It is considered highly probable that the captain was not fastening his shoulder harness at the time of the accident, his body bent forward due to the impact at the time of the crash and he had the chest hit with the cyclic stick. Meanwhile, the mechanic on board, who had her shoulder harness fastened, sustained serious injuries.

4.2 Probable Causes

It is considered highly probable that this crash occurred because the Rod of the Aircraft ruptured during its flight and this made TR uncontrollable and after flying over around the accident site and decelerating, the Aircraft shifted to a rotation to the right and then, it rapidly lost its altitude. As a result, the captain died and the mechanic on board sustained serious injuries.

As to the rupture of the Rod, it is considered highly probable that repetitive bending loads in excess of the fatigue strength had been applied on the Rod due to the loosening of the joint of the Rod and the yaw actuator and the stiffening of the ball pivot as well as a resonance phenomenon following the stiffening.

As to the stiffening of the ball pivot, it is considered highly probable that the phenomenon had

occurred because red rust created with the corrosion of the contact surface of the inner ring and the outer ring caused volume expansion in the space between the two rings and this restricted the movement of the two rings.

As to the crash of the Aircraft, it is considered highly probable that because the Aircraft shifted rotating to the right when the captain performed an operation for deceleration and also because he tried to increase the engine power after that in an attempt to perform a go-around, the rotation to the right accelerated and this made the Aircraft uncontrollable and the Aircraft rapidly lost its altitude.

As to the cause for the captain's death, it is considered highly probable that because the captain had not fastened the shoulder harness, his body bent forward due to the impact at the time of the crash and his heart was damaged as he had his chest hit with the cyclic stick.

5. OPINIONS

In view of the result of this accident investigation, the Japan Transport Safety Board expresses its opinions as follows to the Minister of Land, Infrastructure, Transport and Tourism pursuant to Article 28 of the Act for Establishment of the Japan Transport Safety Board in order to ensure the safety of aviation.

5.1 Implementation of Reliable Maintenance Work in Accordance with Manual

In this accident, maintenance work in accordance with the English written maintenance manual had not necessarily been performed in the circumstances described below.

The troubleshooting for the tail rotor control system was not performed in accordance with the trouble shooting procedure provided in the English written maintenance manual of the aircraft manufacturer. As a result, the inspection of the ball pivot was not performed and its stiffening was not found. In addition, the fact that the joint of the tail rotor control rod and the yaw actuator has a left-handed thread is provided in the English written maintenance manual of the aircraft manufacturer, but it is considered somewhat likely that the mechanic involved in this case, while intending to tighten the joint, actually turned the joint to the opposite direction to loosen it.

Another aircraft accident has been occurred which had been also concerned with noncompliance with the English written maintenance manual of the aircraft manufacturer, other than this accident. Therefore, JCAB should give guidance once again to those in charge of maintenance of rotorcrafts, small aircraft and others so that they will fully understand the contents of manuals and other materials provided by the aircraft manufacturer.

5.2 Appropriate Selection of Flight Training Syllabuses for Emergency Operations in Flight Training

In this accident, it is considered highly probable that the captain did not perform an emergency procedure for the tail rotor failure conditions, as provided in the flight manual. It is considered probable that his failure to perform such an operation reflected the absence of a syllabus for tail rotor failure in the periodic training for the captain.

Therefore, JCAB should give guidance to those who operate rotorcrafts, small aircraft and others so that they will select flight training syllabuses for emergency operations and others in an appropriate manner.

5.3 Fastening of Shoulder Harness

It is considered highly probable that the captain died in this accident because he was not fastening his shoulder harness and as a result, his body bent forward due to the impact at the time of the crash and he had the chest hit with the cyclic stick.

The fastening of the shoulder harness is effective for preventing those who are on board aircraft from sustaining injuries on impacts at the time of crashes and other accidents. Therefore, JCAB should urge those who operate rotorcrafts, small aircraft and others to have pilots and other personnel on board fasten their shoulder harness appropriately, depending on the situation, whenever they perform takeoff and landing.

6. ACTIONS TAKEN

6.1 Measures Implemented by JCAB after Occurrence of the Accident

- (1) On December 11, 2007, JCAB issued Airworthiness Directives TCD-7194-2007 and TCD-7194-1-2007 to instruct visual inspection of the same type of rod.
- (2) On December 14, 2007, JCAB issued an Airworthiness Directive TCD-7194A-2007, and instructed inspections of the same type of rod and ball pivot.
- (3) On December 25, 2007, JCAB issued an Airworthiness Directive TCD-7194B-2007 to instruct repeated inspections of the same type of rod and ball pivot every 50 flight hours.
- (4) On April 16, 2008, JCAB issued an Airworthiness Directive TCD-7194C-2008 to instruct repeated inspections of the same type of rod every 100 flight hours, repeated inspections of the ball pivot and applying corrosion prevention and other measures every 100 flight hours, and repeated inspections of the new type of ball pivot every 400 flight hours or every 12 months, whichever occurs first.
- (5) On November 15, 2010, JCAB issued an Airworthiness Directive TCD-7194D-2010 to instruct to replace the same type of rod to the new type of rod.

6.2 Measures Implemented by the Manufacturer after Occurrence of the Accident

- (1) The Manufacturer issued an Alert Service Bulletin, ASB EC135-67A-017 on December 13, 2007, and Revision 02 on March 17, 2008, to instruct repeated inspections of the same type of rod every 100 flight hours, repeated inspections of the ball pivot and applying corrosion prevention and other measures every 100 flight hours, and repeated inspections of the new type of ball pivot every 400 flight hours or every 12 months, whichever occurs first.
- (2) The Manufacturer issued a Service Bulletin, SB EC-135-67-018 on March 31, 2008, and Revision 01 on May 15, 2008, to introduce replacement to the new type of rod and the new type of ball pivot. But it was not issued as a mandatory of compulsory replacement.

The threaded area of the same type of rod was made of an aluminum-based alloy and it had been fixed by bending the edges of the locking plate. But the threaded area of the new type of rod was made of steel and it was fixed by assembling retainer nuts with radial grooves on the contact surface and a locking washer.

The ball pivot was an inner ring made of a copper-based alloy and an outer ring made of an iron-based alloy. But for the new type of ball pivot, both rings were made of iron-based alloys which had a Teflon coating on the contact surface.

- (3) The Manufacturer issued an Alert Service Bulletin, ASB EC135-67A-017 Revision 03 on July 26, 2010 to instruct replacement of the same type of rod to the new type of rod.

6.3 Measures Implemented by the Company after Occurrence of the Accident

(1) Measures to raise awareness about safety

The Company decided to have senior officials emphasize the importance of securing safety to all employees at various occasions. While conducting case study of this accident, the Company had organized group discussions to reiterate thoroughly to the employees the importance of safety. The Company decided to utilize the case study of this accident, the results of the discussions and other related materials for continuous efforts in the future to raise their awareness about safety.

(2) Measures to strengthen maintenance management system

The Company decided to treat malfunctioning found with important systems and symptoms which may lead to malfunctioning as “designated investigation items” and to establish the operations procedures as a manual. It also decided to convene an “Operations/Maintenance Department Meeting” comprising the General Manager and the division managers of the Operations/Maintenance Department regularly once a month and strengthen efforts for malfunctioning management.

The Company also decided to hold meetings regularly with the Manufacturer and the companies in charge of maintenance for its fleet in an effort to strengthen aircraft management and increase reliability.

The Company increased its maintenance management personnel by one person in April 2008 in an effort to strengthen its maintenance management system.

As a measure to maintain and improve the skills of mechanics, the Company improved its training program for maintenance skill and introduced effective training for the time of maintenance before airworthiness inspections.

(3) Replacement to new types of components

The Company replaced the same type of rod and ball pivot to the new types for all aircraft of the type in its fleet.

(4) Confirmation of pilots’ emergency operations ability and skill improvement regarding the same type of aircraft as the accident aircraft

The Company implemented lectures and retraining flights with actual aircraft regarding procedures for emergency operations in TR control system failure and confirmed captains’ knowledge and ability concerning emergency operations. The Company decided to incorporate the training contents in “training and evaluation rules” in its internal regulations in order to maintain and improve the skills of its personnel through periodic training and periodic evaluation. The Company decided to prepare an emergency check list and have the check list on board its aircraft.

(5) Measures to strengthen total safety operations management system

In order to perform an effective internal audit, the Company newly established a “Safety Audit Office” in April 2008 and introduced a safety management system in April 2009.

(6) Measures to strengthen operations management system

The Company introduced satellite telephones to all its aircraft so that the Operations Control Division can obtain and manage real-time information about the positions of aircraft in flight and in order to unify and strengthen its operations management system, the Company increased its operations control personnel by one person in January 2008.

Figure 1 Estimated Flight Route

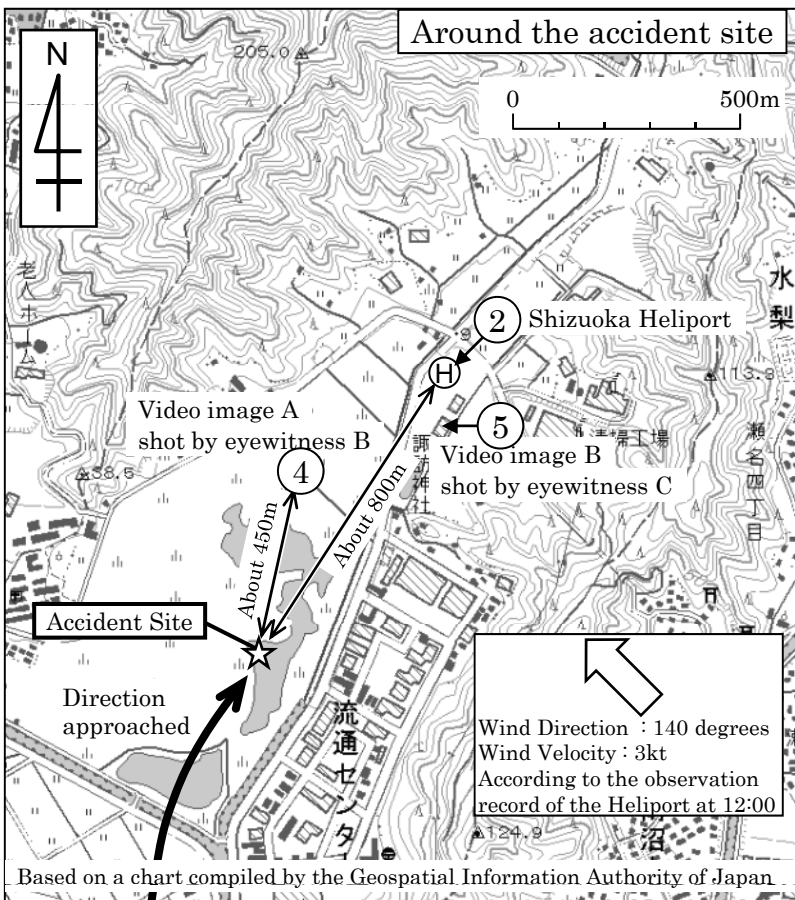
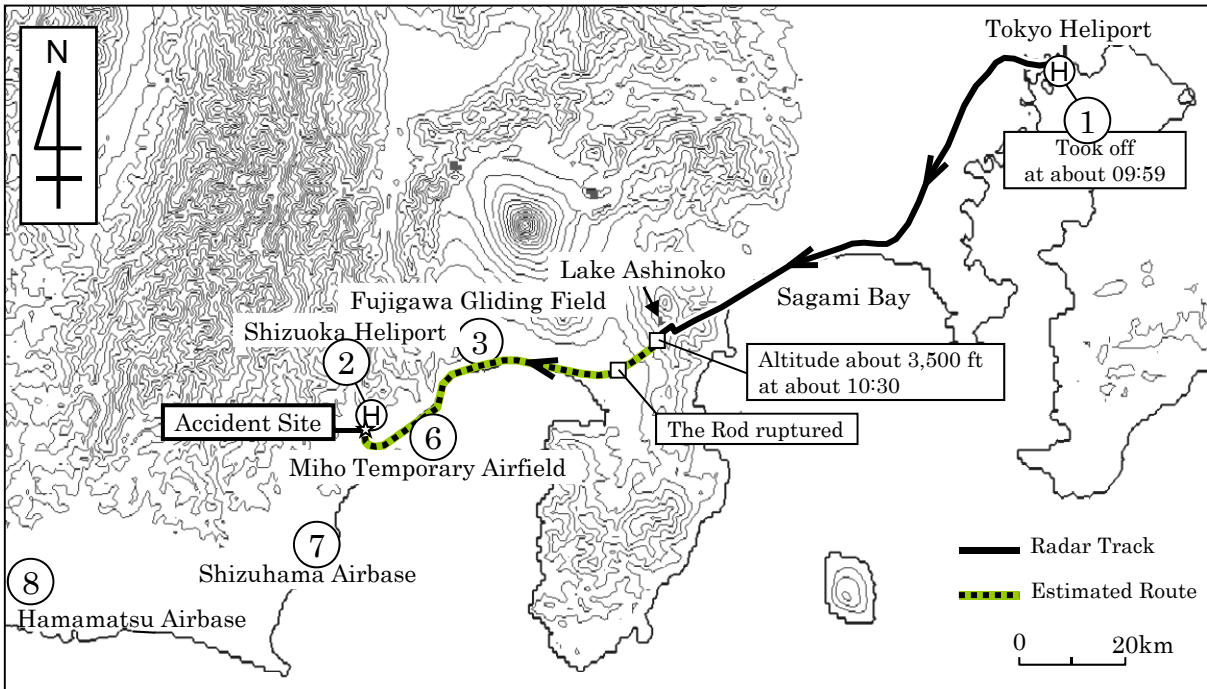

- ① Tokyo Heliport
- ② Shizuoka Heliport
- ③ Eyewitness A at Fujigawa Gliding Field
- ④ Video image A shot by eyewitness B
- ⑤ Video image B shot by eyewitness C
- ⑥ Miho Temporary Airfield
- ⑦ Shizuhamma Airbase
- ⑧ Hamamatsu Airbase

Based on a chart compiled by the Geospatial Information Authority of Japan

Figure 2 Three Angle View of Eurocopter EC135T2

Unit: m

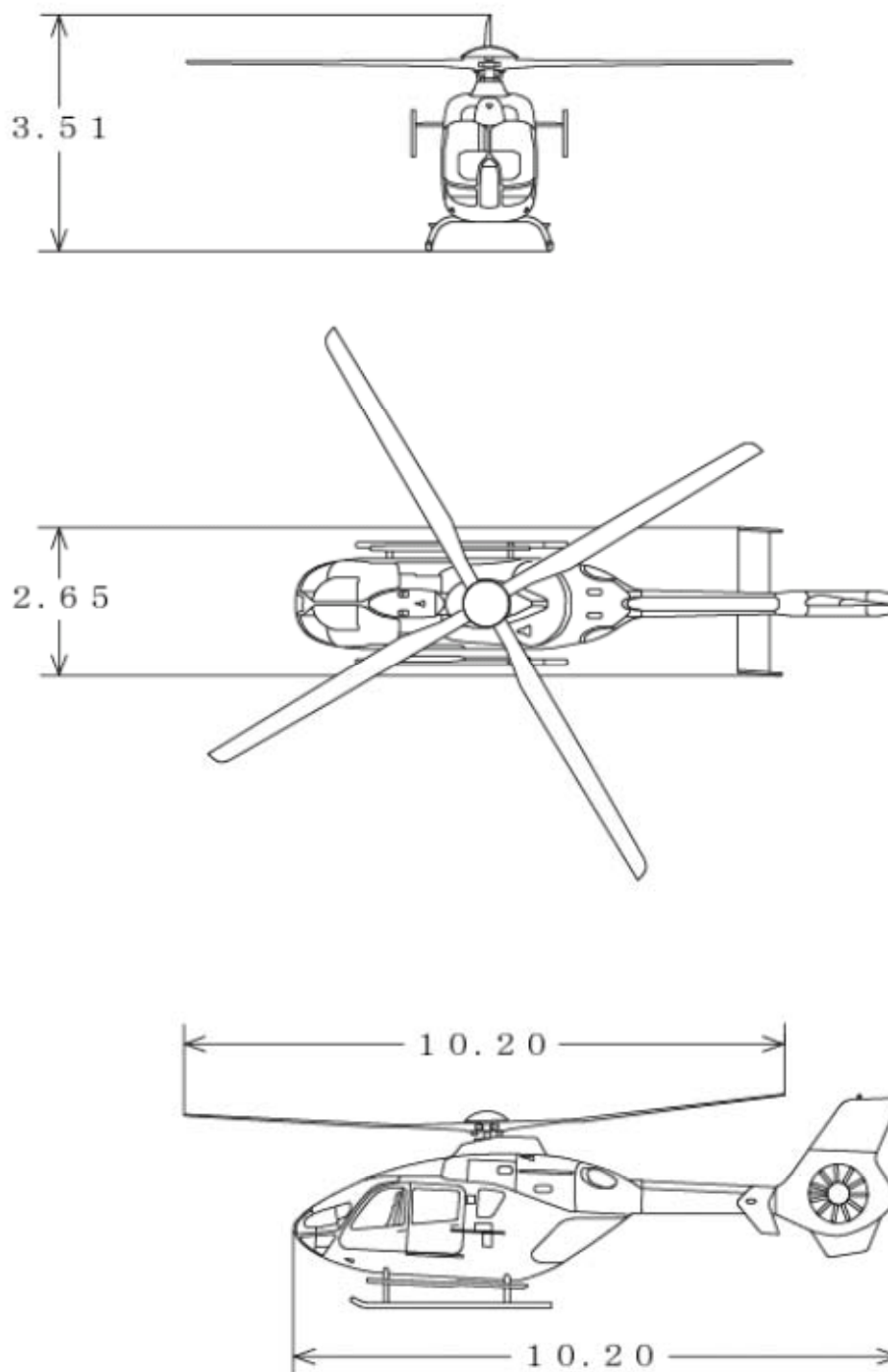

Figure 3 TR Control System

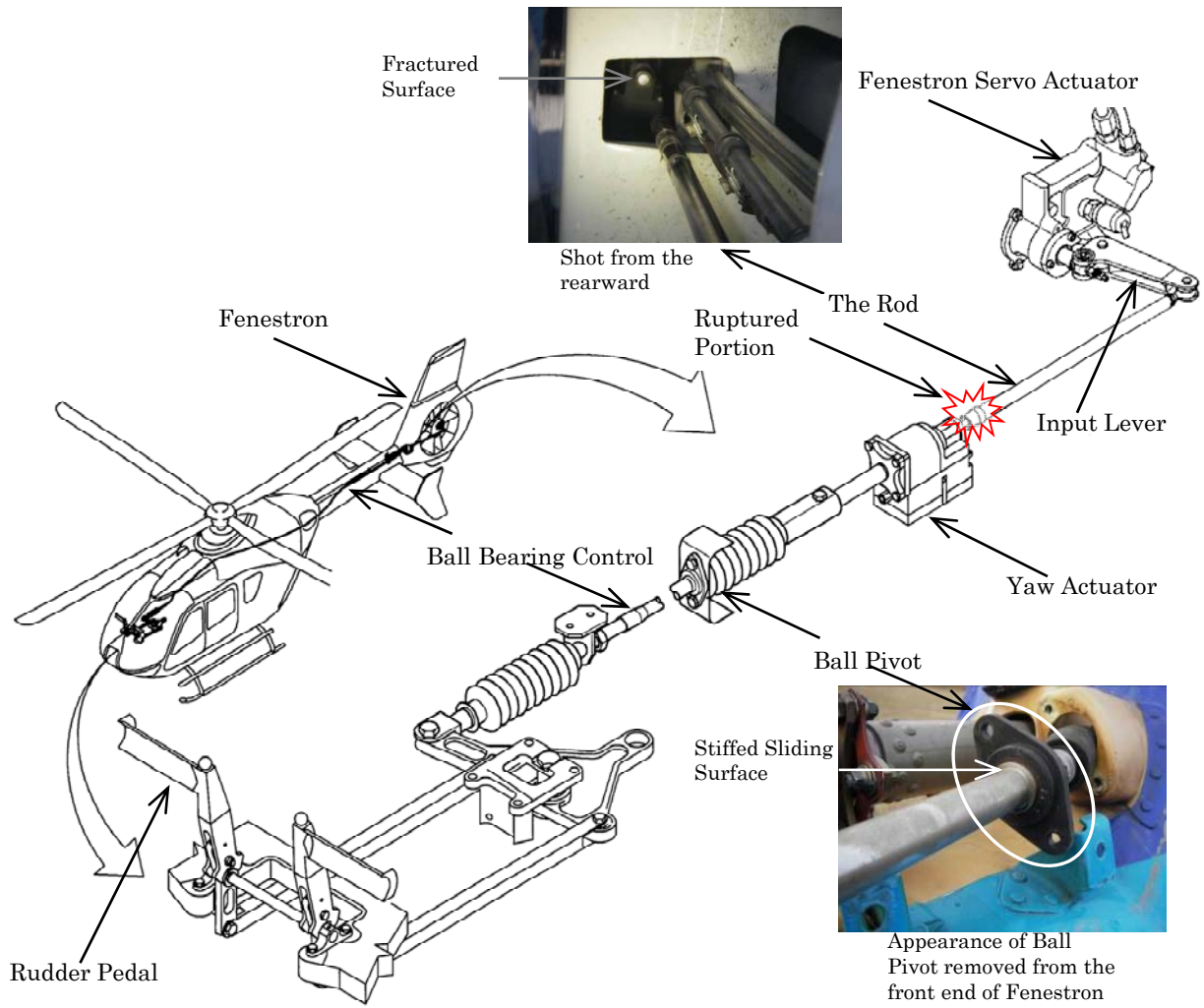

Figure 4 Ruptured Portion and Movable Range of the Rod

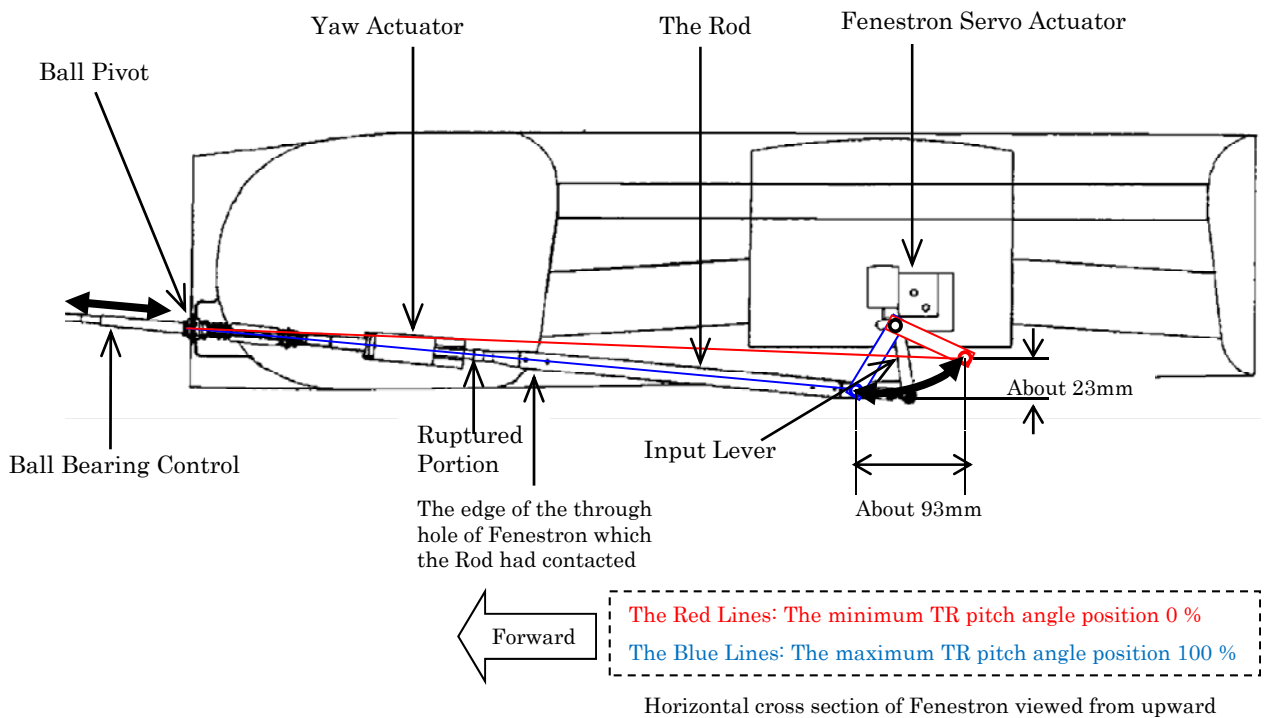
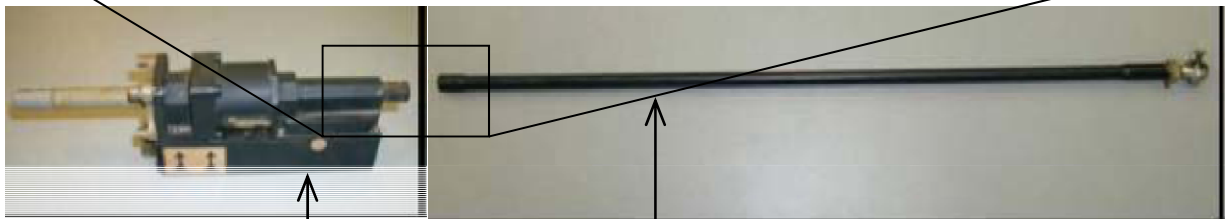
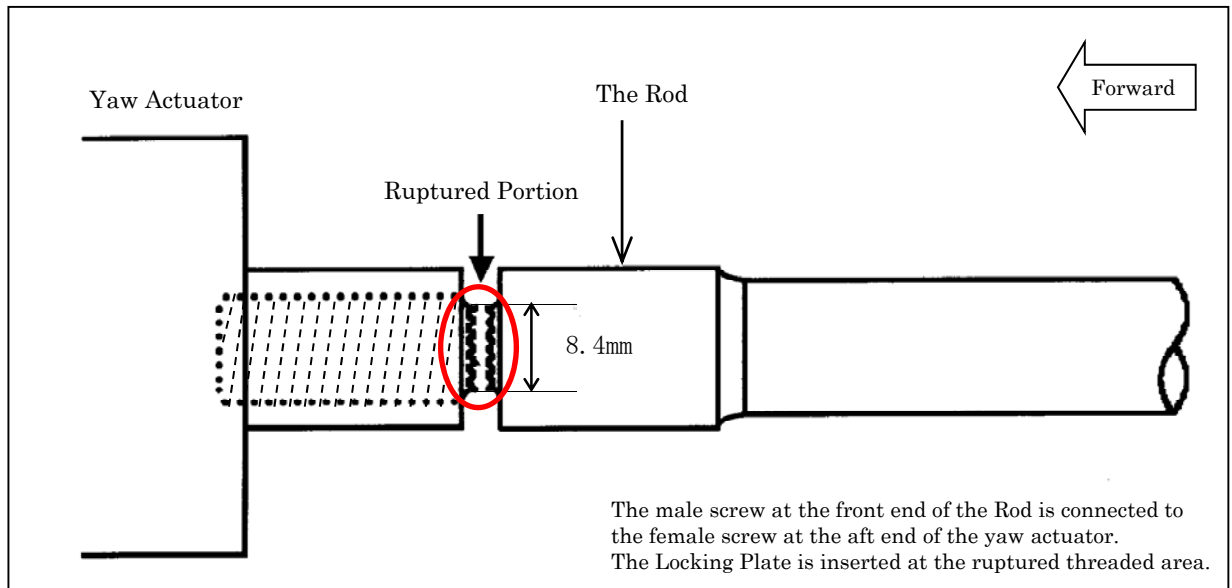

Figure 5 Video Images Taken by Eyewitnesses



Video image A about 52 s before the crash



Video image B about 10 s before the crash



Video image A about 48 s before the crash



Video image B about 9 s before the crash



Video image A about 33 s before the crash



Video image B about 8.5 s before the

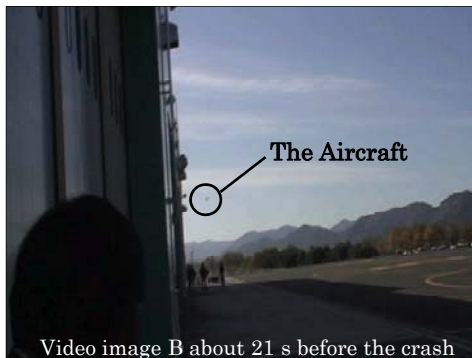

Video image B about 21 s before the crash



Video image A about 5 s before the crash

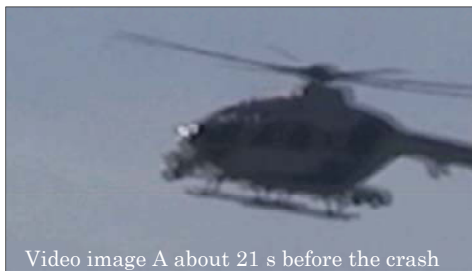

Video image A about 21 s before the crash



Video image A about 2 s before the crash



Video image A about 11 s before the crash

Photo 1 Accident Aircraft



Photo 2 Marks Left on the Rod

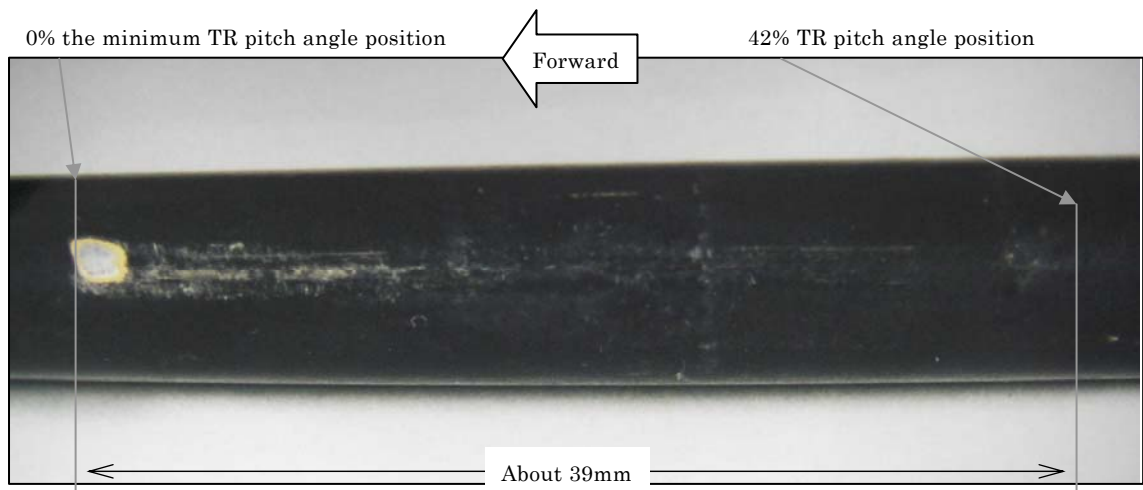

The edge of the through hole of Fenestron which the Rod had contacted

Photo 3 Fractured Surface in the Front Side of the Rod

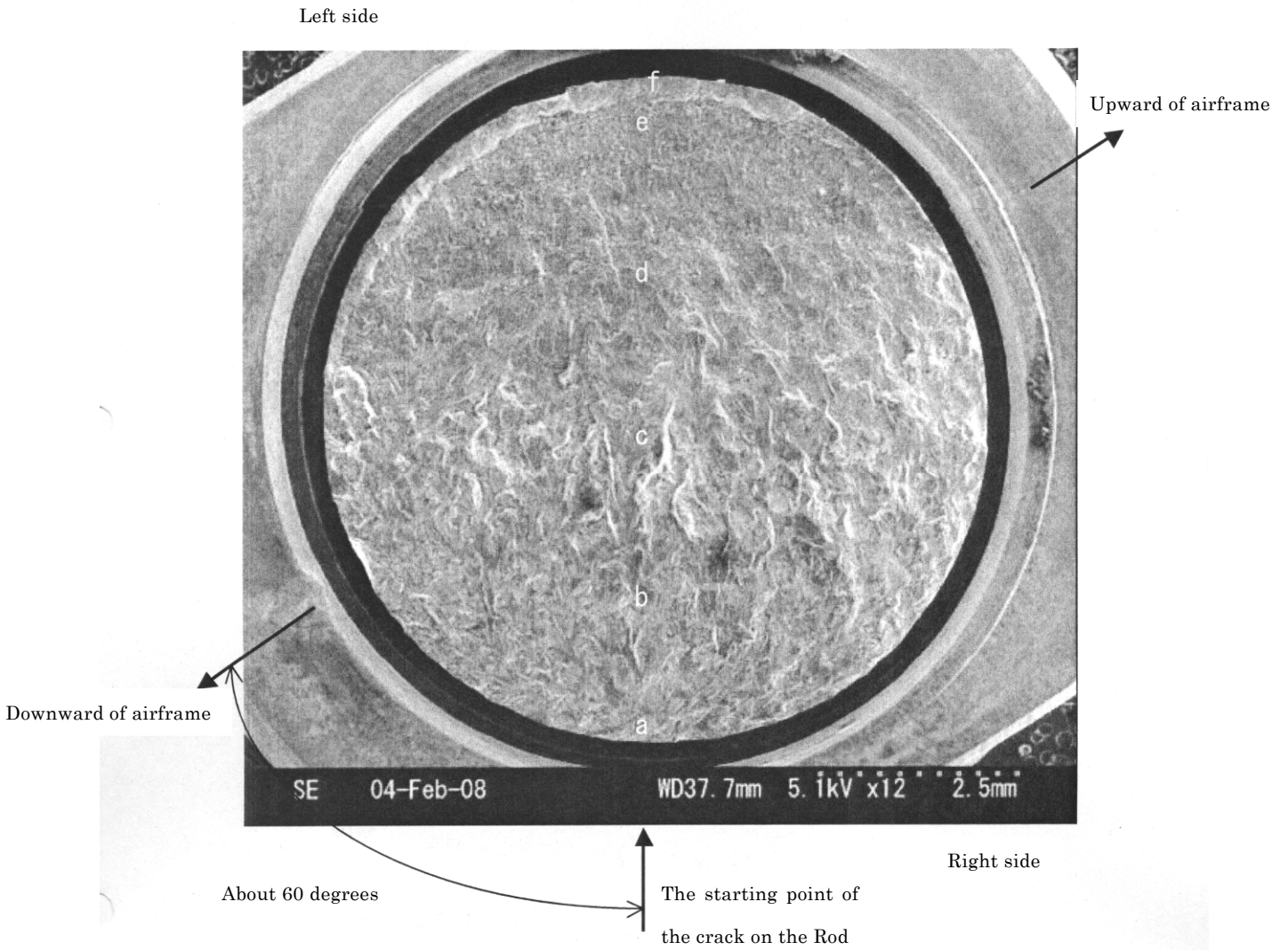

Photo 4 Ball Pivot after Cut Off

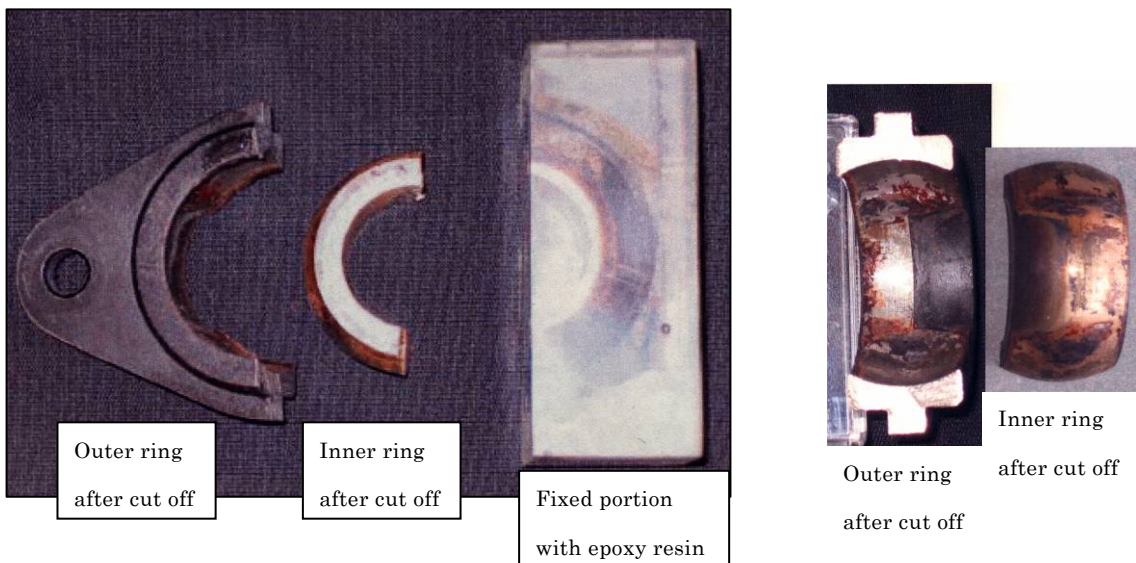
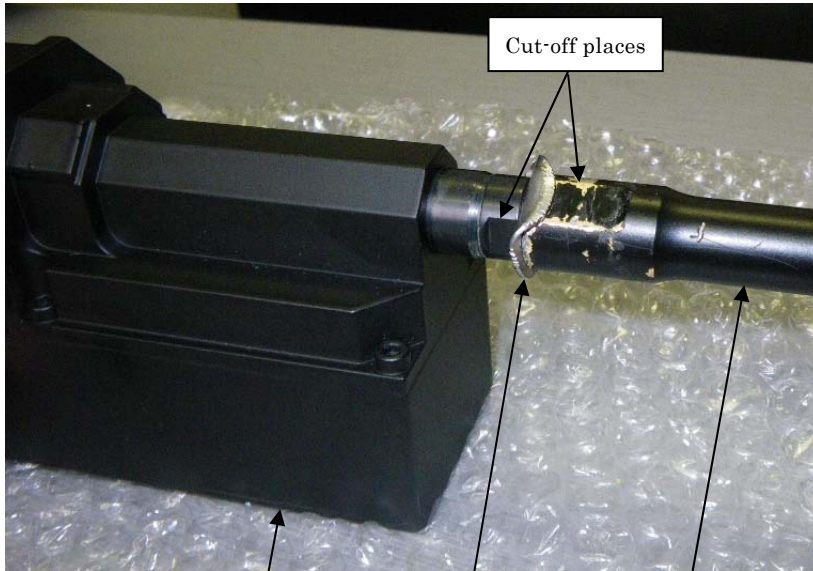
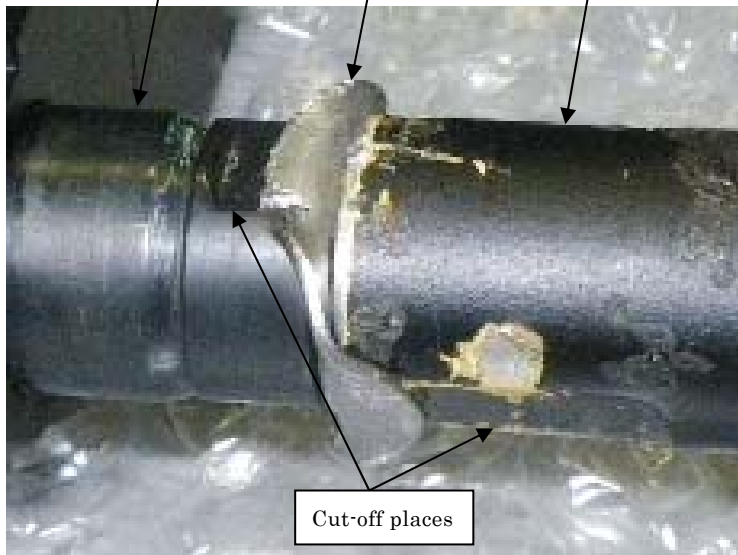

Photo 5 Locking Plate



The bending of the Locking Plate to the Yaw Actuator side had been accomplished at a cut-off place of Yaw Actuator which is opposite side of that of seeing on this Photo.

Yaw Actuator Locking Plate Type of Rod



Shot after rolling over the Yaw Actuator to the forefront side from the appearance of above photo



Locking Plate before bending