

AA2009-8

**AIRCRAFT ACCIDENT
INVESTIGATION REPORT**

**PRIVATELY OWNED
J A 2 3 8 2**

September 18, 2009

Japan Transport Safety Board

The investigation for this report was conducted by the Japan Transport Safety Board, JTSB, about the aircraft accident of Privately Owned, Alexander Shleicher ASK23B registration JA2382 in accordance with the act for the Establishment of the Japan Transport Safety Board and Annex 13 to the Convention on the International Civil Aviation for the purpose of determining causes of the aircraft accident and contributing to the prevention of accidents/incidents and not for the purpose of blaming responsibility of the accident.

This English version of this report has been published and translated by the JTSB to make its reading easier for English speaking people who are not familiar with Japanese. Although efforts are made to translate as accurately as possible, only the Japanese version is authentic. If there is any difference in the meaning of the texts between the Japanese and English versions, the text in the Japanese version prevails.

Norihiro Goto,
Chairman,
Japan Transport Safety Board

AIRCRAFT ACCIDENT INVESTIGATION REPORT

PRIVATELY OWNED,

ALEXANDER SCHLEICHER

ASK23B (GLIDER, SINGLE-SEATED)

JA2382

FUJIOKA TOWN, SHIMOTSUGA COUNTY, TOCHIGI PREFECTURE,

AT ABOUT 15:12 JST, DECEMBER 28, 2008

September 4, 2009

Adopted by the Japan Transport Safety Board
(Aircraft Sub-committee)

Chairman	Norihiro Goto
Member	Yukio Kusuki
Member	Shinsuke Endo
Member	Noboru Toyooka
Member	Yuki Shuto
Member	Akiko Matsuo

1. PROCESS AND PROGRESS OF THE AIRCRAFT ACCIDENT INVESTIGATION

1.1 Summary of the Accident

On December 28 (Sunday), 2008, a privately operated Alexander Schleicher ASK23B, registered JA2382, hit a tree under the final approach path and crashed to the ground at about 15:12, while approaching the Itakura Gliding Field during a leisure flight. The Captain, who was the only person on board, was killed. The glider was destroyed.

1.2 Outline of the Accident Investigation

1.2.1 Investigation Organization

On December 28, 2008, the Japan Transport Safety Board (JTSB) designated an investigator-in-charge and one investigator to investigate this accident.

1.2.2 Representative from Foreign Authorities

An accredited representative of Germany, as the State of Design and Manufacture of the glider, participated in the investigation.

1.2.3 Implementation of Investigation

December 29, 2008: Wreckage investigation, on-site investigation and interviews

December 30, 2008: Interviews

1.2.4 Comments from Parties relevant to the Cause of the Accident

Not conducted: the pilot deceased.

1.2.5 Comments from the Participating State

Comments were invited from the participating state.

2. FACTUAL INFORMATION

2.1 History of the Flight

On December 28, 2008, a privately owned Alexander Schleicher ASK23B, registered JA2382 (hereinafter referred to as “the Glider”), took off from the Itakura Gliding Field (hereinafter referred to as “the Gliding Field”) by airplane towing for a leisure flight. After being released from the tow-plane, while approaching the Gliding Field, the RH wing of the Glider hit a tree under the final approach path, the Glider crashed to the ground and was destroyed, at about 15:12 JST (Japan Standard Time, unless otherwise indicated, all time JST, UTC+9h). The Captain, who was the only person on board, was killed.

According to the following statements of witnesses and persons involved, the history of the flight is outlined below:

- (1) A club member who had flown the Glider earlier the same day

With the assistance of the Captain of the accident (hereinafter referred to as “the Captain”) and other club members, we took the Glider from the trailer and greased it up. After the pre-flight briefing by the Japan Soaring Club (hereinafter referred to as “the Club”) at 10:30, we assembled the Glider, together with the Captain.

I got on board the Glider first. I was towed-up at 14:21 and completed landing at 14:40 in the Gliding Field. I had no trouble in the Glider during the flight. After landing, I told the Captain that the prevailing winds were quite strong.

I have not flown the Glider many times. But I have an experience that I unintentionally opened the Air Brakes slightly, when I pulled the handle too hard in trying to disengage the Air Brakes during a landing with another type of glider in the past.

This was the first time for the Captain to fly the Glider. The Captain did not appear to be in a bad physical condition.

- (2) Witness A: Glider Instructor

I observed the Glider from beside the runway. The Glider entered the down wind leg of the west traffic pattern in order to land. The Gliding Field has a west traffic pattern for gliders, and the altitude is set at 700 ft, or 200 m. It is necessary to raise the altitude to 800 – 900 ft during strong wind conditions. The Glider entered the traffic pattern at an altitude suitable for calm wind, but I thought the altitude was a little low for the strong wind that was blowing that particular day. However, the Glider was maintaining an airspeed that was higher than that suitable for calm wind conditions. Even so, as the position of the base leg was not too far, I thought that although the Glider could not touch down at the preferred point of the runway, it would land safely within the runway.

I saw that the Air Brakes were deployed twice on the final approach, and I wondered why the Captain deployed them while approaching slightly lower than the normal desired approach path. The Air Brakes closed immediately both times, but the Glider sunk as a result, and I knew the Glider would not make it when I saw it sink even further the second time. The Glider hit a tree and crashed to the ground. The attitude of the Glider was stable before the Air Brakes were deployed.

The Air Brake handle of the Glider is located on the left side of the cockpit and is designed to be operated with the left hand using a straight-line motion. The Air Brakes are completely closed and locked when the handle is in the fully forward position, and completely

open when the handle is in the fully backward position. There are cases where unaccustomed pilots unintentionally open the Air Brakes by pulling the handle too hard when unlocking fully-closed Air Brakes. However, as I could clearly see the orange of the Air Brakes above the wings both times when the Air Brakes were deployed just before the crash, the Air Brakes are likely to have been opened to a substantial extent, rather than being unintentionally opened when disengaging the lock. It would have been necessary for pilots to hold the Air Brake handle firmly during the strong wind conditions, because on some occasions, at high airspeed, partial opening of the Air Brakes can occur due to negative pressure building up over the upper surface of the wing, but on no occasion would the Air Brakes open fully unless intentionally activated.

The Air Brakes are designed to adjust the approach path angle, and it is not necessary to deploy it on every approach. As an instructor at the club, I have noticed that some inexperienced pilots tend to use the Air Brakes as his own standard procedure, even when they are not necessary.

I was aware of the tree under the final approach path, but I have not cared about the height of the tree during landing before.

Soon after the accident occurred, I dialed 119 (emergency call) from the piste.

(3) Witness B: Glider Instructor

I had flown just before the accident in another glider, and I experienced strong and rough wind.

At 14:59, when the Captain took-off, the Glider was observed being towed at an unstable pitch and relatively low-tow, but it eventually recovered stability, and continued climbing.

A little while later, I saw the Glider making its final approach for about 10 seconds. Normally, gliders approach at an altitude of about three times the height of the tree. However, I thought something was wrong when I saw the Air Brakes open while the glider was already flying lower than the altitude required to achieve the appropriate approach angle under calm wind conditions. The nose of the Glider seemed to tilt slightly upward, and the Air Brakes were immediately closed. However, the Glider hit the top of a tree, and crash-landed with the RH wing lower. It was about 15:12.

I immediately rushed to the accident site by car. Before an ambulance arrived, I unfastened the Captain's seat belt and shoulder harness and pulled him out of the Glider. The Captain was unconscious and the ambulance took him to a hospital.

The Captain joined the Club about two years ago. I instructed him several times in the past. He progressed favorably in training and was enthusiastic. The Captain obtained his license about one year ago. I think that this was his first flight in the Glider, and moreover, his first flight in a single-seated glider. At the time, nobody in the Club was aware that, because he had not mentioned it. Single-seated gliders are different from dual seated gliders in weight, and in steering feel substantially. The sink rate in strong wind conditions varies significantly by the types of gliders, and also the affects of the Air Brakes are different by the types of gliders. He must have undergone take-off and landing training under strong wind conditions, but I think he faced that kind of experience not so much .

(4) Flight Operation Chief, Piste

The Captain waited for some time at the piste for the wind to calm down. Runway 33 was in use, and the wind at the piste at 15:00 was coming from 310 degrees at a velocity of 4 – 5 m/s with no gusts. The piste observation point is located just behind the dike, so I think the

upper wind could be stronger than the ground level wind. In addition to a windsock and an anemometer installed at the piste, windsocks are installed at both ends of the runway. Pilots can watch the windsocks at the runway ends to confirm the prevailing wind conditions. All of the gliders except the Glider had returned to the Gliding Field by the time the Glider took off.

After a while the Captain reported that the Glider was released from the tow-plane at an altitude of 3,000 ft, he reported entering the downwind leg. I responded to the Captain that the landing runway was clear. The Captain responded "Roger". No radio contact was made after that. I did not see the moment the accident occurred.

(5) Flight Instructor, in charge of the Annual Flight Review

On December 20, 2008, a week before the accident, an Annual Flight Review (AFR¹) for the Captain was conducted as required by the rules of the Club, and I was assigned as the instructor. The weather on that day was not rough. Although the Captain had not flown a glider for about three months, there was no problem in his proficiency. However, when he received the oral question, "What would you do if you experienced a significant and continuing sink just prior to touch-down?" he did not seem to fully understand the importance of flaring depending on the sink rate if an appropriate speed is being maintained, and if not, closing the Air Brakes. Thus, I explained these matters to him, and he seemed to understand them at least in theory. This AFR is not a qualification test to fly solo in a single-seated glider.

The accident occurred under the final approach path to runway 33 of the Itakura Gliding Field (Itakura Town, Oura County, Gunma Prefecture), about 460 m SE from the marker plates of the runway (N36°15'40" E139°38' 22") at 15:12.

(See Figure 1 – Estimated Flight Route, Figure 2 – Key Maps of Accident Site, Photo 1 – Accident Aircraft and Accident Site, Photo 2 - Cockpit and RH Wing, Photo 3 – A Tree)

2.2 Injuries to Persons

The Captain was killed.

2.3 Damage to the Aircraft

2.3.1 Extent of Damage

Destroyed

2.3.2 Damage to the Aircraft Components

Fuselage: Nose section and main landing gear attachment section were destroyed.

Wing connecting section was damaged

Wings: Both Left and Right Hand Wings were damaged

Tail assembly: Rudder suffered numerous scratches.

(See Figure 3 – Three Angle View of Alexander Schleicher ASK23B, Photo 1 –

¹ Annual Flight Review: The AFR is one of the safety measures that the Club adopted itself. This procedure is intended to apply all the pilots who fly from the Gliding Field as captains. Every captain is required to receive the AFR flying with an instructor every 12 months. Unless a captain receives the AFR, he or she is not permitted to fly at the Gliding Field. The AFR is not intended as a qualification test, or an examination in terms of pass or fail.

2.4 Other Damage

Work shed: Glass windows and shutter were damaged.

(See Photo 1 – Accident Aircraft and Accident Site)

2.5 Personnel Information

(1) Captain: Male, Age 50

Private pilot certificate (glider)	November 16, 2007
Rating: Soarer	November 16, 2007
Private pilot certificate (Airplane)	September 25, 2008
Class 2 aviation medical certificate	
Validity	December 6, 2009
Total flight time	unknown
Total flight time in glider	42 h and 26 min. (148 flights)
Flight time in the last 30 days	0 h and 14 min
Flight time in glider	0 h and 14 min (1)
Total flight time on the type of glider	0 h 00 min

(2) The Captain joined the club in March 2008. According to the Captain's flight record, between September 27, 2008, and the recent Annual Flight Review of December 20, 2008, the Captain had not flown in a glider. The gliders that the Captain had only flown in the past were 2 types of dual seated gliders of the club. He had no experience with the same type of the Glider. The Captain had logged a total of 7 hours and 1 minute captain time.

The Captain traveled to Indonesia to receive multi-engine flight training for about a week in the latter half of November 2008.

2.6 Aircraft Information

2.6.1 Aircraft

Type	Alexander Schleicher ASK23B
Serial number	23085
Date of manufacture	November 10, 1986
Certificate of airworthiness	No. 2008-54-06
Validity	Until December 12, 2009
Category of airworthiness	Glider, Utility
Total flight time	489 h 35 min
Flight time since last periodical check (on December 13, 2008)	1 h 17 min

2.6.2 Weight and Balance

It is estimated that, at the time of the accident, the gross weight of the Aircraft was about 320 kg and the center of gravity was about 443 mm aft of the reference point; both parameters were within the allowable limits. (Maximum takeoff weight: 360 kg; the center of gravity corresponding to the weight at the time of the accident: 285–455 mm.)

(See Figure 3 – Three Angle View of Alexander Schleicher ASK23B)

2.7 Meteorological Information

Wind direction and velocity observed at the piste of the Gliding Field were as follows:

15:00 Wind direction...310° Wind velocity... 4–5m/s, No gusts

15:30 Wind direction...310° Wind velocity... 4–5m/s, No gusts

Wind direction and velocity observed at the observational stations of the Automated Meteorological Data Acquisition System located near the Gliding Field around the time of the accident were as described below. Clear daylight had been recorded from 07:30 to 16:10, at each station.

Wind Direction and Wind Velocity (m/s)

	15:10		15:20	
	Average	Max	Average	Max
Tatebayashi	WNW, 7.2	NW, 12.6	NW, 6.7	WNW, 13.6
Koga	WNW, 6.2	WNW, 12.5	WNW, 5.5	NW, 11.3
Sano	WNW, 5.0	-	WNW, 7.0	-

Tatebayashi [Gunma Prefecture] (About 10 km W from the Gliding Field)

Koga [Ibaraki Prefecture] (About 10 km SE from the Gliding Field)

Sano [Tochigi Prefecture] (About 7 km NW from the Gliding Field)

2.8 Accident Site and Wreckage Information

2.8.1 Condition of the Accident Site

The Gliding Field is located on the right bank of the Watarase River, at an elevation of about 18 m above mean sea level (MSL). The Gliding Field has a Runway 33/15, which is about 1,000 m long and about 70 m wide. The runway is divided into three sections: the dike side is designated as section A, and is used for mainly for take-offs; the center section is designated as section B; and the river side is designated as C. Both sections B and C are used for landing purposes, but priority for landings is given to section C.

The accident site is under the final approach path to section C of runway 33 of the Gliding Field, and is located at about 460 m SE from the marker plates of runway 33, on the other side of the dike (altitude: about 25 m; the height from the landing area: about 7 m) on the right bank of the Watarase river from the Gliding Field. The Glider was found pointing in the direction of about 060°, about 40 m toward the Gliding Field from a tree that is about 20 m tall and is located about 500 m SE from the marker plates.

The top of the tree snapped off and fell to the ground on the N to NE side of the base of the tree. About 30 m from the tree, in the direction of the Gliding Field, traces of the initial impact of the RH wingtip were left, and about 5 m beyond, traces of the Nose section impact were left. From there to the place where the destroyed main landing gear was found, there were marks showing that the main landing gear had skidded sideways in a straight line.

About 15 m from the traces of the impact point of the RH wingtip, in the direction of the Gliding Field, traces of the impact of the LH wingtip were left. Broken branches of a lower tree were found about 10 m from the impact point of the RH wingtip. The left side of the Rudder surface showed signs that it had made contact with the lower tree.

The LH wingtip hit the shutter of the work shed, which is about 45 m NW of the taller tree.

(See Figure 1 - Estimated Flight Route, Figure 2 – Key Maps of Accident Site, Photo 1 – Accident Aircraft and Accident Site, Photo 2 - Cockpit and RH Wing, Photo 3 – A Tree)

2.8.2 Details of Aircraft Damage

(1) Fuselage

- The connecting section of the LH wing was broken, and the nose section was twisted down to the left.
- The nose section was turned more to the right than the Aircraft's direction (magnetic direction of 60°.)
- The canopy was damaged and fragments were scattered around.

(2) RH wing

- The wing was detached from the pin at the rear connecting section of the wing
- From about 1 m from the wingtip to about 1.9 m inward, along the wing, the leading edge was split into two main parts: the upper and lower sections. Numerous scratch marks and paint peeling off were found on the upper surface of the wing's forward section.
- A crack was found about 1.2 m inward from the wingtip. Ground soil was stuck to the lower surface the wingtip.
- The Air Brake was fully open, and the actuation rod was bent at a point near the wing connecting section.

(3) LH wing

- The wing connecting section was destroyed.
- Numerous cracks and wrinkles were found on the upper surface, and scratches caused by impact with the ground were found on almost the entire length of the leading edge and the lower part of the wingtip.
- The Air Brake was fully open, and the actuation rod was bent at a point near the wing connecting section.

(4) Tail assembly

- Marks of impact with the lower tree were found on the left surface of the Rudder.

(5) Flight control system

- Neither the Aileron nor the elevator responded to control column operation.
- The Rudder did not respond to rudder pedals operation.
- The Air Brake was in the almost-fully-open position and the Air Brake did not respond to handle operation.

(See Photo 1 – Accident Aircraft and Accident Site, Photo 2 - Cockpit and RH Wing)

2.9 Medical and Pathological Information

(1) According to the police, the cause of death of the Captain was “Traumatic thoracic aorta rupture”.

(2) According to the fire department, the process and progress of rescue operations were as follows:

About 15:20	Emergency call was received.
About 15:26	Ambulance and rescue crew arrived at accident site. Survival medical treatment applied.
About 15:38	Ambulance departed from the accident site.
About 15:53	Ambulance arrived at the hospital.

2.10 Additional Information

- (1) The following is described in the flight operation manual for the glider. (Extract)

Chapter 4 Normal Operation

10. Approach and Landing

Final Approach speed: approx. 80 km/h

During rough air approach, additional airspeed is recommended.

A stable, deep angle approach can be made with the assistance of the Air Brakes.

Disengaging the lock position of the Air Brakes is recommended at the initial phase of the final approach.

(The rest is omitted.)

- (2) The club also provides the following rules. (Extract)

JSC (Japan Soaring Club) Checkout procedures

1. Objective

(Omitted) *In order to ensure proficiency of captains, and assist smooth transition of the type rating, and also to promote safety in all operational phases, confirmation of knowledge and skills (hereinafter referred to as the “check”) shall be made by an instructor approved by the Japan Glider Club (hereinafter referred to as the “instructor”).*

2. Scope

Every private and commercial pilot (hereinafter referred to as the “captain”) of any glider or motor glider “taking off” from the Itakura gliding field are targeted. (The rest is omitted.)

3. Types of Checks

If any of the matters described in the following Table 1 apply, captains shall report such matters to the instructor on the day of the flight, before flying, as necessary, and receive a check by the instructor.

Management of flight experience (flight time and flight frequency) and the ascertaining of the flight type shall be the responsibilities of individual captains.

Table 1

<i>3.1</i>	<i>Check for type rating</i>	<i>3.1.1</i>	<i>First solo flight with planned type of glider</i>
<i>3.2</i>	<i>Check based on recent flight experience</i>	<i>3.2.1</i>	<i>If flight frequency in a glider or motor glider at the gliding field is 3 times or less in the preceding 90 days</i>
		<i>3.2.2</i>	<i>If the captain’s total flight time is 60 hours or less, every flight</i>

3. ANALYSIS

3.1 Airman Competence Certificate and Aviation Medical Certificate

The Captain held both a valid private pilot certificate and an aviation medical certificate.

3.2 Airworthiness Certificate

The Glider had a valid airworthiness certificate and had been maintained and inspected as prescribed.

3.3 Weather Condition

As described in 2.7, the wind observed at the piste around the time of the accident was coming from 310° at a velocity of 4–5 m/s. However, as described in 2.1 (4), when the wind comes from the NW to W, the wind is often measured to be weaker than the actual velocity since the piste will be downwind from the dike, which blocks the wind. Judging from this fact as well as the wind direction and velocity observed at the observational stations of the Automated Meteorological Data Acquisition System within a 10 km radius of the Gliding Field as described in 2.7, it is considered highly probable that the actual upper winds have been slightly stronger than the wind observed at the piste.

Based on the descriptions in 2.1 (4), and 2.7, it is considered highly probable that, although the Captain took off after waiting for the wind to calm down, the wind was actually still strong and changes in the wind velocity were substantial.

3.4 Condition of the Aircraft and Captain

As described in 2.1, when a club member flew the Glider prior to the Captain's flight, no trouble was observed in it during the flight, when the Captain reported to the piste that the Glider was entering the downwind leg of the Gliding Field, the report contained no information indicating any abnormal state in particular, and the attitude of the Glider was stable before the Air Brakes were deployed. Therefore, it is considered highly probable that there was nothing wrong with the Glider.

In addition, from the oral statement in 2.1(1), it is considered probable that the Captain had no physical problems.

3.5 Familiarization with the Aircraft

According to the designer and manufacturer of the Glider, it was classified as a "Basic flight trainer." And it is a single-seated model used for flight training and other purposes in Japan. But as described in 2.5, the Captain had not flown the same type of the Glider, nor had he flown a single-seated glider in the past, although the Captain had flown solo in a dual seated glider. Therefore, it is considered highly probable that the Captain was not familiar with the characteristics of the Glider.

3.6 The Circumstances of the Accident

3.6.1 Before Flying

As described in 2.1, it is considered highly probable that the Captain arrived at the

Gliding Field before 10:30, assembled the Glider with the Club members, and waited for the wind to calm down. As other gliders that flew the day had returned and dusk was approaching, it is considered possible that the Captain was eager to fly directly after the Club member who flew the Glider before him.

As described in 3.5, it was the Captain's first time to fly the same type of the Glider and also his first time in a single-seated glider, the Captain's flights at the Gliding Field in the preceding 90 days had not exceeded three times (only one flight on December 20, 2008), and his total flight time had not exceeded 60 hours. Therefore, it is certain that the Captain was required to report to a club instructor of the need to receive the check specified by the Club rules as described in 2.10(2), but he failed to do so before flying.

It is considered highly probable that, before take-off, the Club member who flew before him informed the Captain that the wind was strong. Considering that the Captain had little experience of flying in strong winds, as presumed based on the description in 3.5 and the oral statement in 2.1(3), it was necessary for him to seek advice from the instructor when deciding whether or not to fly, given the strong wind conditions on that day.

3.6.2 Traffic Pattern

As described in 2.1, it is considered highly probable that the Glider was towed-up from the Gliding Field, was released at an altitude of about 3,000 ft, and entered the downwind leg of the west traffic pattern on returning to the Gliding Field. It is considered probable that, at that time, the Captain had initiated the approach at an altitude of about 200 m, which is the standard initial approach height for calm wind conditions. However, considering the wind conditions as described in 3.3, the Glider should have entered the downwind leg at a slightly higher altitude.

At this approach, the Glider did not make a short cut from the base leg to the final approach course. Therefore, it is considered probable that the Captain was not aware that the altitude flown at the base leg was too low to reach the runway. It is considered probable that, since the wind was strong, the speed of the Glider was faster than normal, but the altitude was not sufficiently high.

3.6.3 Final Approach

It is considered probable that the Captain had disengaged the lock of the Air Brakes on the final approach path to prepare for the landing. Based on the descriptions in 2.1, it is considered highly probable that the Air Brakes have opened twice even though the altitude was lower than that appropriate for normal, calm wind conditions. Since a witness saw the orange of the Air Brakes clearly over the wings, the extent of opening the Air Brakes were not mere that of unintentional opening caused by negative pressure applied on the surface of the wings when unlocking the Air Brakes. Rather, even if they had slightly opened due to such negative pressure when being unlocked, it is considered probable that the Air Brakes have been opened substantially after that by the Captain's operation.

As described in 2.5, the captain had been flying at the Gliding Field for over two years, and had accumulated at least 42 hours of flight time. Therefore, it is considered probable that the Captain had a good understanding of the target path angle to be taken in the route surrounding the Gliding Field. Hence, it is considered probable that he had been able to judge the desired final approach angle, and had been aware that he was at an insufficient altitude

during the final approach. Based on these findings, it is considered probable that the Captain had not used the Air Brakes because he felt that the approach altitude was too high. As described in 2.5(2), however, the Captain had received flight training for multi-engine aircraft about one month before the accident, it is considered possible that, the transition of maneuvering feeling from an airplane to a glider, the approach angle of which is steeper than that of an airplane, was insufficient .

As described in 2.1(2) and (3), the glider sunk significantly when the Air Brakes were deployed, and the Glider hit the top part of a tree. Therefore, it is considered highly probable that the Glider could have landed without hitting the tree if the Air Brakes were not deployed. Judging from this, it is considered probable that, before the Air Brakes were deployed, the altitude of the Glider was not so low as to have led the captain to carry out erroneous operation from confusion.

It is considered possible that any of the following matters or a combination thereof was involved in the captain's action of deploying the Air Brakes at a low approach altitude, but the reason why the Captain deployed the Air Brakes could not be ascertained.

(1) As described in 2.1(2), the Captain deployed the Air Brakes as his own standard procedure for final approach.

(2) As described in 2.1(5), at the time of the AFR, the Captain did not seem to have a full understanding of the sink rate and flaring just prior to touch down, but after being given explanations by the instructor, he seemed to understand, at least in theory. But in reality, the Captain, who had limited flight experience, was unable to put that theory into practice during the actual flight.

(3) The Captain, who was flying the Glider for the first time, was trying to identify changes in the speed and approach angle as well as in the feel of the sinking of the Glider when the Air Brakes were being opened.

3.7 Tree under the Final Approach Path

As described in 2.8.1, although there was a tree under the final approach path for runway 33, the height of which was lower than the required approach surface of a Temporary Operation Airstrip (600 m landing distance). Therefore, it is certain that the tree had not obstructed the Glider's landing.

3.8 Administration and Operation of the Club, and the Members' Self Awareness

In order to prevent accidents, the Club members had voluntarily established the Annual Flight Review and other Checks. In order to ensure safety, given that the Club is intended for adult members, it is necessary that each Club member becomes sufficiently aware of his/her responsibilities as a pilot, and strictly observes the rules established based on the consent of the Club members, while understanding the intention and the importance of those rules.

4. PROBABLE CAUSE

In this accident, it is considered probable that, during the final approach to the Gliding Field, the Glider crashed to the ground, as the Captain deployed the Air Brakes despite a low altitude, the Glider losing altitude, then the RH wing hit the top of a tree under the final approach path.

The reason why the Captain deployed the Air Brakes could not be ascertained.

5. REFERENTIAL MATTERS

After this accident, the Club held a meeting to reconfirm safety, with the participation of all Club members. The Club members identified problems related to each of the following three categories: Man, Machine, and Environment. The identified problems were classified by their nature and countermeasures against those problems were discussed by forming the following four working groups.

WG-1: Review of Piste Functions

WG-2: Review of Rules

WG-3: Review of the Management of Pilots

WG-4: Review of Equipment and Facilities

As a result of the discussions, it was decided that the JSC Checkout Procedures shall be strictly observed. More specifically, it was decided that the management of the Flight Experience Records of captains with 60 hours or less of flight time and the ascertaining of the flight type shall not only be the responsibility of each individual pilot, but shall also be managed by flight instructors.

The tree that the Glider hit was cut down by the Club after the accident, after the owner's permission was obtained.

Figure 1 Estimated Flight Route

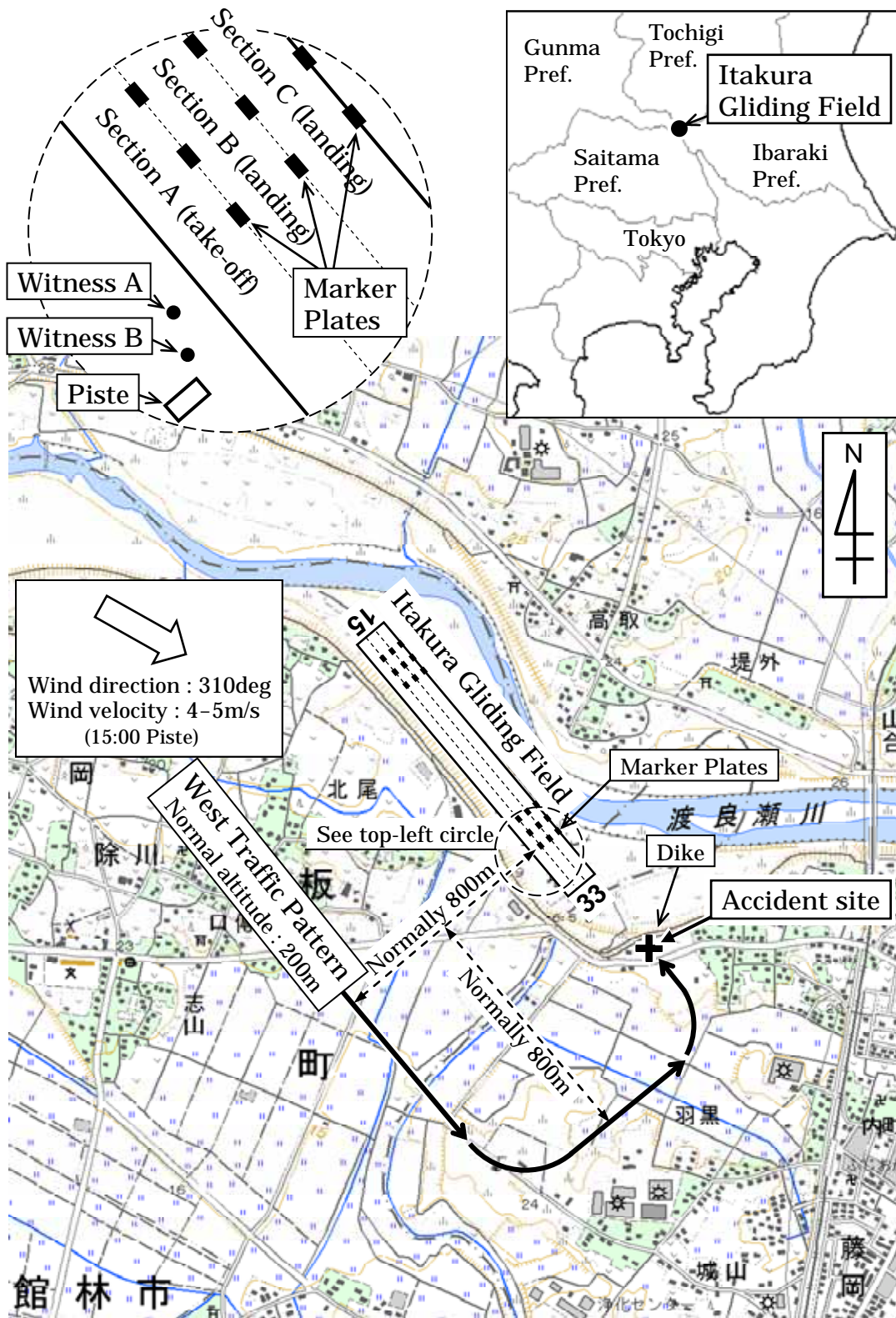

1:25,000 Scale Topographic Map by Geographical Survey Institute

Figure 2 Key Maps of Accident Site

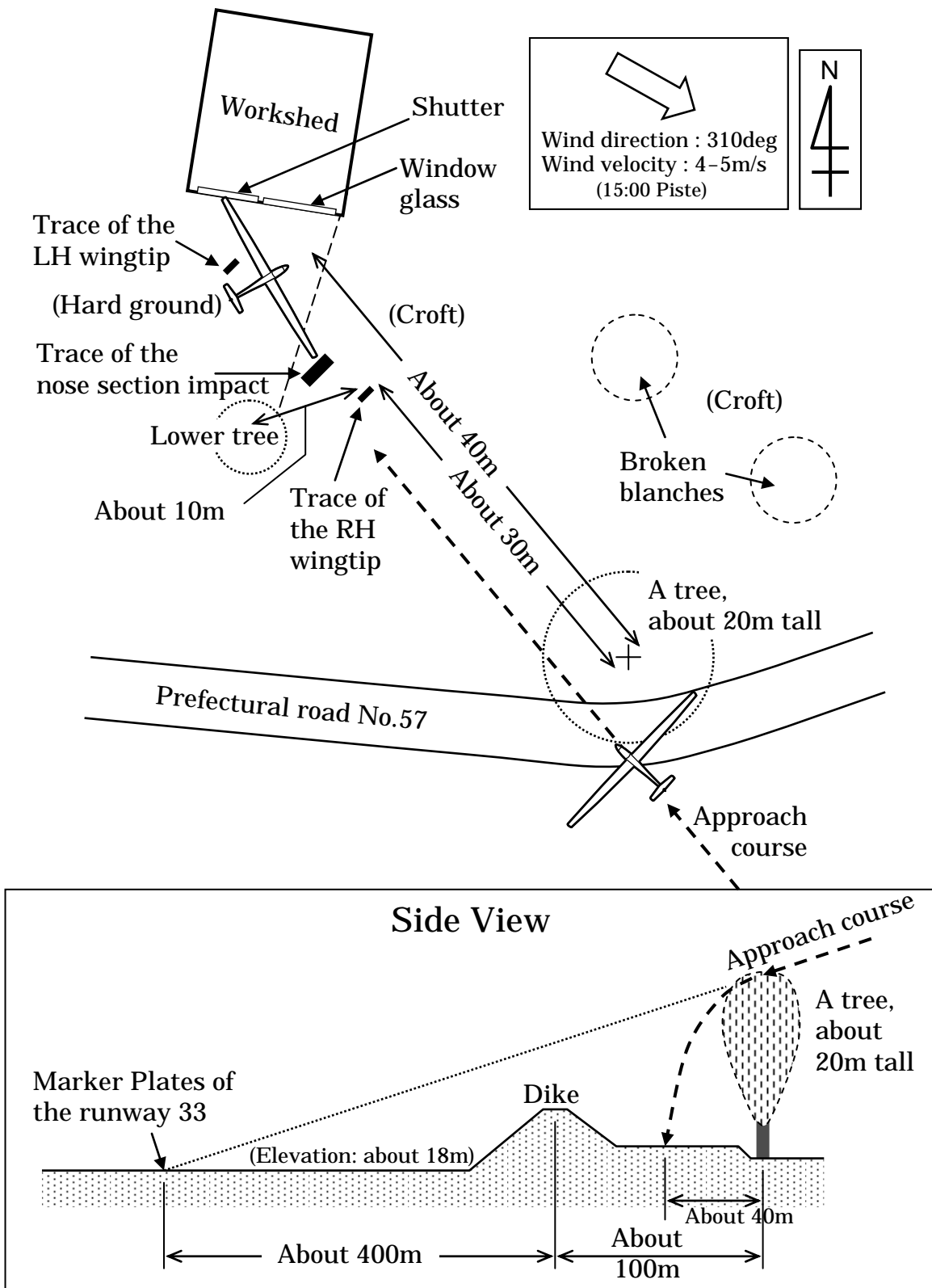

Figure 3 Three Angle View of Alexander Schleicher ASK23B

Unit : m

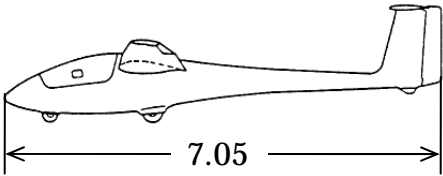
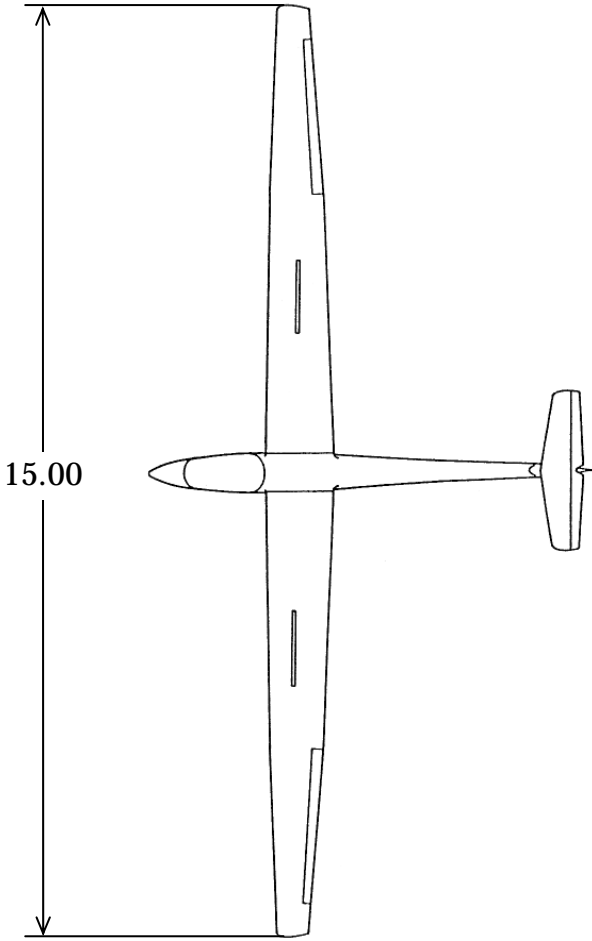
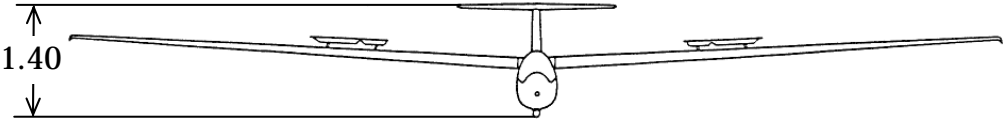
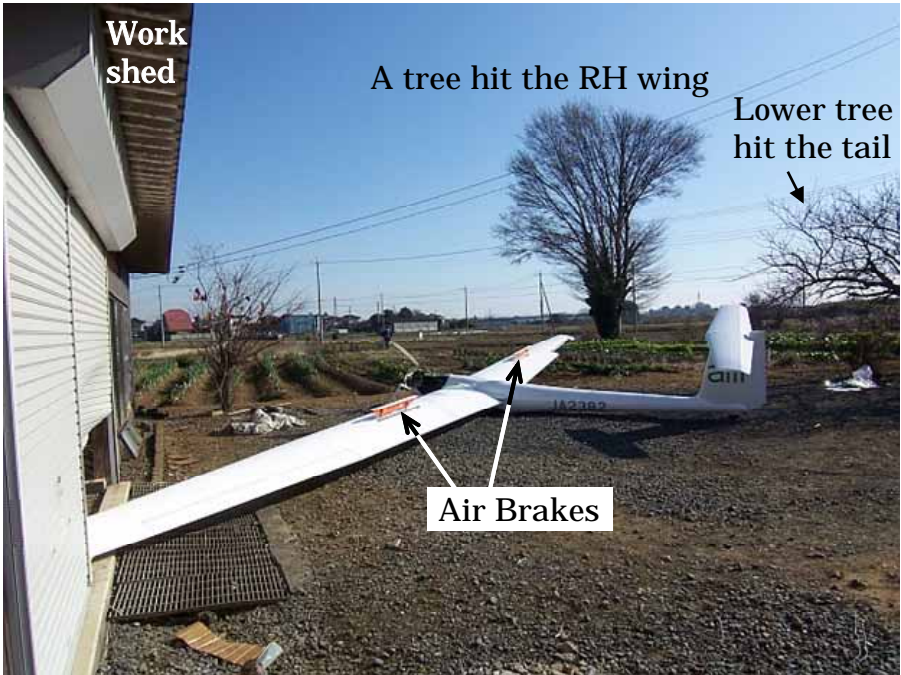

Photo 1 Accident Aircraft and Accident Site



The glider was approaching from the other side.



The glider was approaching to the section C over the dike.

Photo 2 Cockpit and RH Wing

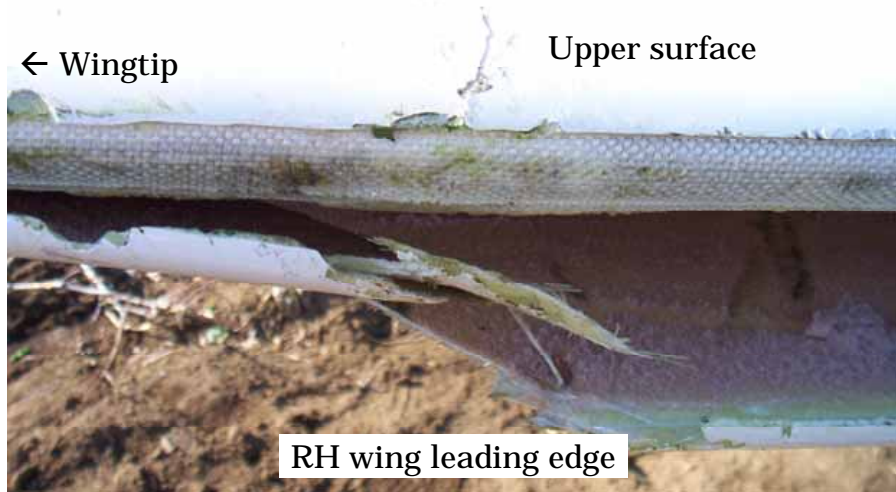
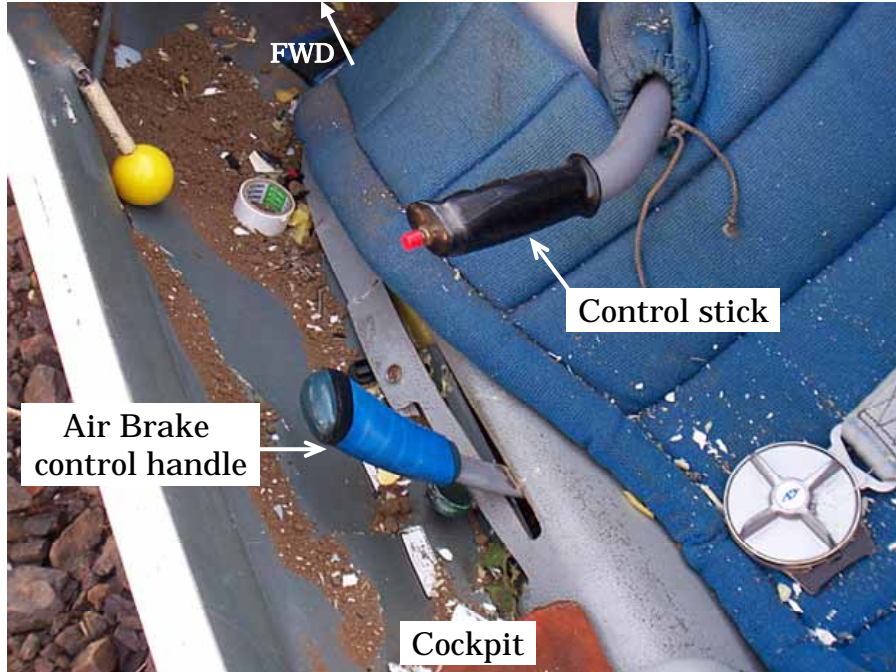

Photo 3 A Tree

